



Company Information
Systems Overview
Programmable Controllers
Field I/O
Software
C-more & other HMI

Drives
Soft Starters
Motors & Gearbox
Steppers/ Servos
Motor Controls
Proximity Sensors
Photo Sensors
Limit Switches
Encoders
Current Sensors
Pressure Sensors
Temperature Sensors
Pushbuttons/ Lights
Process
Relays/ Timers
Comm.
Terminal Blocks & Wiring
Power
Circuit Protection
Enclosures
Tools
Pneumatics
Safety
Appendix
Product Index
Part # Index

GS/DURAPULSE Accessories – Fusing

Fusing Overview

Circuit protection devices are essential to prevent costly damage to your AC drive application equipment. Fuses and fuse kits are available from AUTOMATIONDIRECT for the GS2 and DURAPULSE AC drives. (AutomationDirect GS style fuses and fuse

kits are NOT available for GS1 drives at this time.)

The fuse specifications are shown in the table below. Each fuse kit consists of one fuse block and fuses sized to handle the inrush current while providing superior protection for the corresponding GS2 or DURAPULSE AC drive. The larger drives

in the DURAPULSE family require three fuse kits (one per phase). Their part numbers are marked in the table with a double asterisk.

Replacement fuses are also available, and listed in the table next to their companion fuse kits.

Fuse Kit Specifications for GS2 and DURAPULSE 115–460V Drives										
Fuse Kit	Price	Fuse Block Type	Wire Range	Fuse Type	Fuse Block Dimensions	Fuse Rating	Replacement Fuses (5 fuses per package)	Price		
GS-10P2-FKIT-1P*	<-->	Two-pole	Al/Cu #2-14	A3T	Figure 1	300V@20A	GS-10P2-FUSE-1P	<-->		
GS-10P5-FKIT-1P*	<-->					300V@20A	GS-10P5-FUSE-1P	<-->		
GS-11P0-FKIT-1P*	<-->					300V@20A	GS-11P0-FUSE-1P	<-->		
GS-20P2-FKIT-1P	<-->					300V@15A	GS-20P2-FUSE-1P	<-->		
GS-20P2-FKIT-3P	<-->	Three-pole			Figure 2	300V@10A	GS-20P2-FUSE-3P	<-->		
GS-20P5-FKIT-1P	<-->	Two-pole				300V@20A	GS-20P5-FUSE-1P	<-->		
GS-20P5-FKIT-3P	<-->	Three-pole			Figure 2	300V@10A	GS-20P5-FUSE-3P	<-->		
GS-21P0-FKIT-1P	<-->	Two-pole			Figure 1	300V@30A	GS-21P0-FUSE-1P	<-->		
GS-21P0-FKIT-3P	<-->	Three-pole			Figure 2	300V@20A	GS-21P0-FUSE-3P	<-->		
GS-22P0-FKIT-1P	<-->	Two-pole			Figure 1	300V@45A	GS-22P0-FUSE-1P	<-->		
GS-22P0-FKIT-3P	<-->	Three-pole			Figure 2	300V@25A	GS-22P0-FUSE-3P	<-->		
GS-23P0-FKIT-1P	<-->	Two-pole			Figure 1	300V@60A	GS-23P0-FUSE-1P	<-->		
GS-23P0-FKIT-3P	<-->	Three-pole			Al/Cu 2/0-#6	A6T	Figure 2	300V@40A	GS-23P0-FUSE-3P	<-->
GS-25P0-FKIT	<-->							300V@60A	GS-25P0-FUSE	<-->
GS-27P5-FKIT	<-->						Figure 9	300V@100A	GS-27P5-FUSE	<-->
- †							Figure 4	300V@125A	GS-2010-FUSE	<-->
- †			300V@175A	GS-2015-FUSE				<-->		
GS-2020-FKIT	<-->		Figure 5	300V@250A			GS-2020-FUSE	<-->		
GS-2025-FKIT	<-->			300V@300A			GS-2025-FUSE	<-->		
GS-2030-FKIT	<-->			300V@350A			GS-2030-FUSE	<-->		
GS-2040-FKIT**	<-->		One-pole	Figure 6 ***			300V@450A	GS-2040-FUSE	<-->	
GS-2050-FKIT**	<-->		One-pole				300V@500A	GS-2050-FUSE	<-->	
GS-41P0-FKIT	<-->	Three-pole	Al/Cu #2-14	A6T	Figure 7	600V@10A	GS-41P0-FUSE	<-->		
GS-42P0-FKIT	<-->					600V@15A	GS-42P0-FUSE	<-->		
GS-43P0-FKIT	<-->					600V@20A	GS-43P0-FUSE	<-->		
GS-45P0-FKIT	<-->					600V@30A	GS-45P0-FUSE	<-->		
GS-47P5-FKIT	<-->				Figure 8	600V@50A	GS-47P5-FUSE	<-->		
GS-4010-FKIT	<-->					600V@70A	GS-4010-FUSE	<-->		
GS-4015-FKIT	<-->				Figure 9	600V@90A	GS-4015-FUSE	<-->		
GS-4020-FKIT	<-->					600V@125A	GS-4020-FUSE	<-->		
GS-4025-FKIT	<-->				Figure 10	600V@150A	GS-4025-FUSE	<-->		
GS-4030-FKIT	<-->					600V@175A	GS-4030-FUSE	<-->		
GS-4040-FKIT**	<-->					600V@225A	GS-4040-FUSE	<-->		
GS-4050-FKIT**	<-->				Figure 11 ***	600V@250A	GS-4050-FUSE	<-->		
GS-4060-FKIT**	<-->	600V@350A	GS-4060-FUSE	<-->						
GS-4075-FKIT**	<-->	600V@400A	GS-4075-FUSE	<-->						
GS-4100-FKIT**	<-->	One-pole	Figure 12 ***	600V@600A	GS-4100-FUSE	<-->				

NOTES:
* – Single phase 115V fuse kits are for use only with GS1 and GS2 drives.
** – Kit includes three single-pole fuse blocks and three fuses.
† - GS-2010-FKIT and GS-2015-FKIT are no longer available. Please use GS-27P5-FKIT instead.

GS/DURAPULSE Accessories – Fusing

Fuse Specifications for GS2 575V Drives					
GS2 Drive Model	Edison Fuse Block	Fuse Block Type	Fuse Class	Fuse Rating	Edison Fuses (10 fuses per pack)
GS2-51P0	BC6033PQ or CHCC3D or CHCC3DI	3-pole or 3-pole modular or 3-pole modular indicating	CC	6A@600V	HCLR6
GS2-52P0				10A@600V	HCLR10
GS2-53P0				15A@600V	HCLR15
GS2-55P0				20A@600V	HCLR20
GS2-57P5				30A@600V	HCLR30
GS2-5010					

NOTE:
Refer to the Edison Fuses section of this catalog for pricing, specifications, and dimensions.

Fuse Block Dimensions

Units = inches

Figure 1

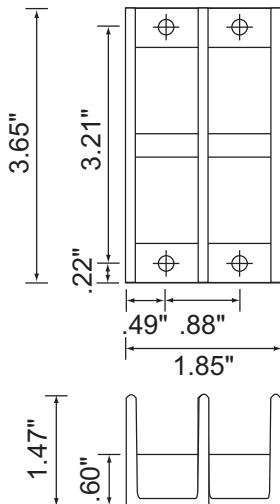

Figure 2

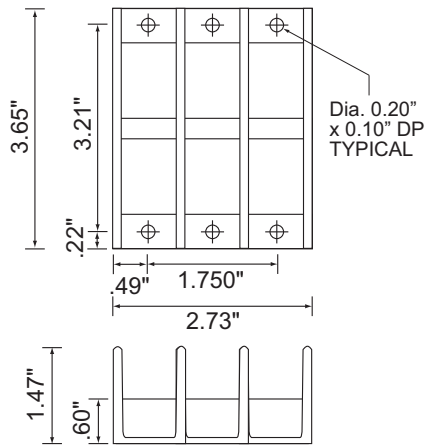

Figure 3

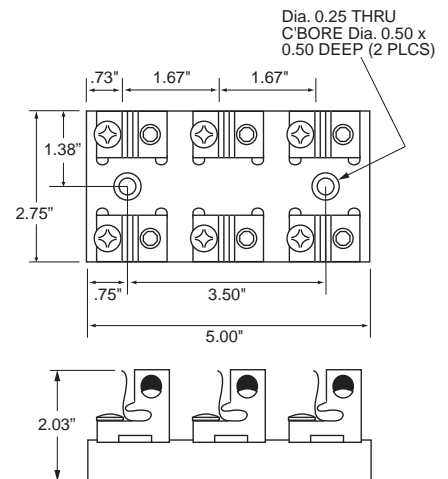

Figure 4

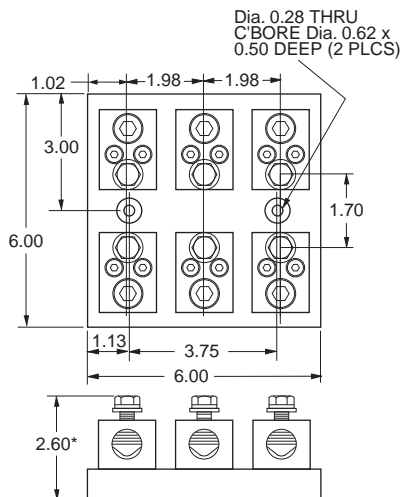

Figure 5

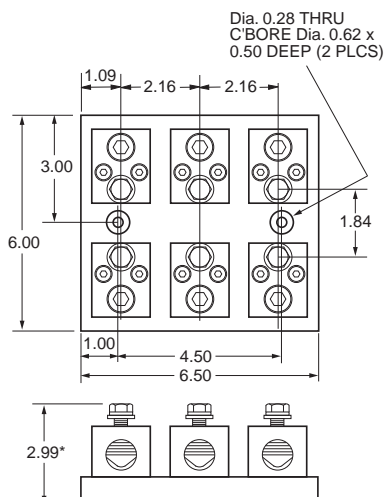
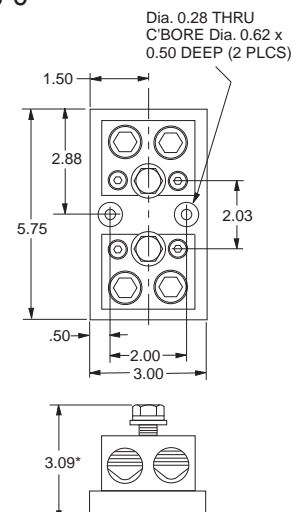

Figure 6



GS/DURAPULSE Accessories – Fusing

Fuse Block Dimensions

Units = inches

Figure 7

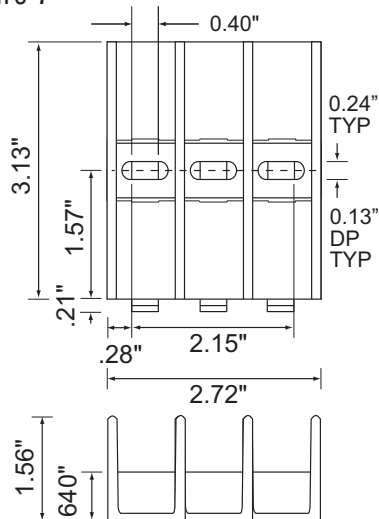

Figure 8

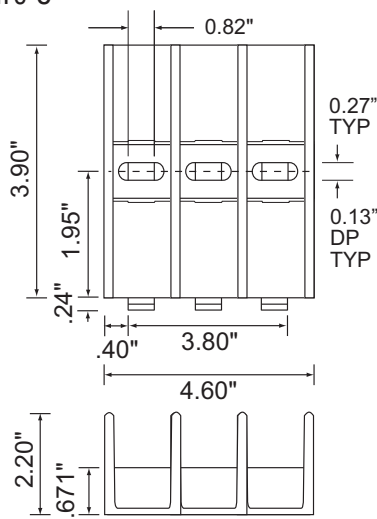

Figure 9

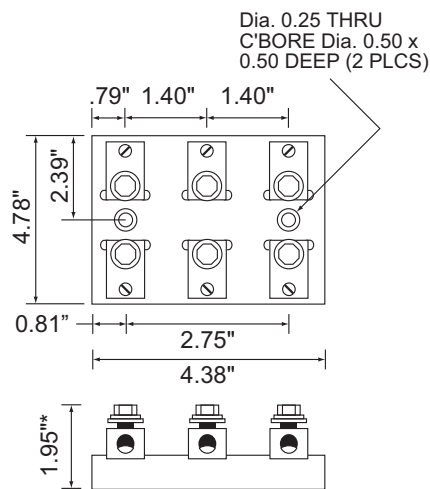

Figure 10

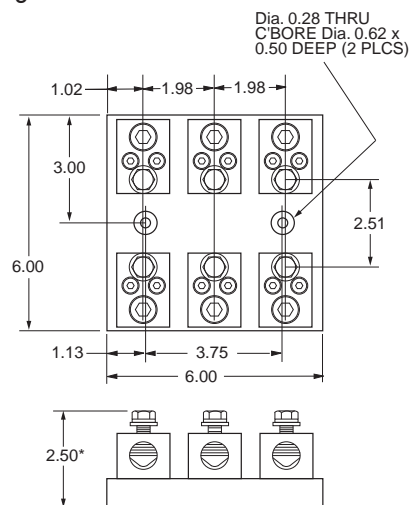

Figure 11

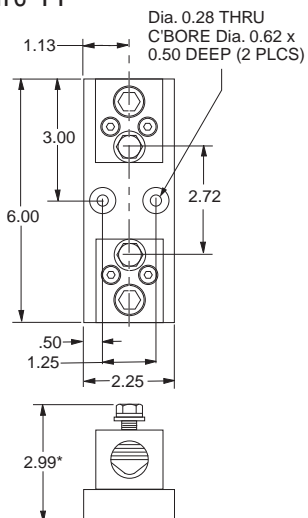
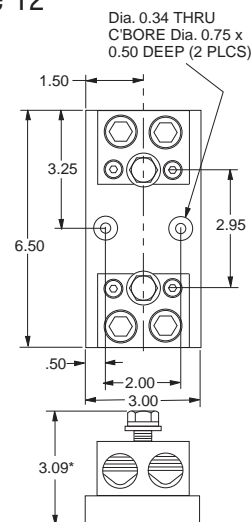

Figure 12



* Height includes nominal fuse blade thickness.

GS/DURAPULSE Accessories – Overview

Accessories – Part numbering system

Note: With the exception of the EMI filters, RF filters, and LR series line reactors, each accessory part number begins with GS, followed by the AC Drive rating, and then the relevant accessory code. Following the accessory code, you will find a description code when applicable. The diagram at right shows the accessory part numbering system.

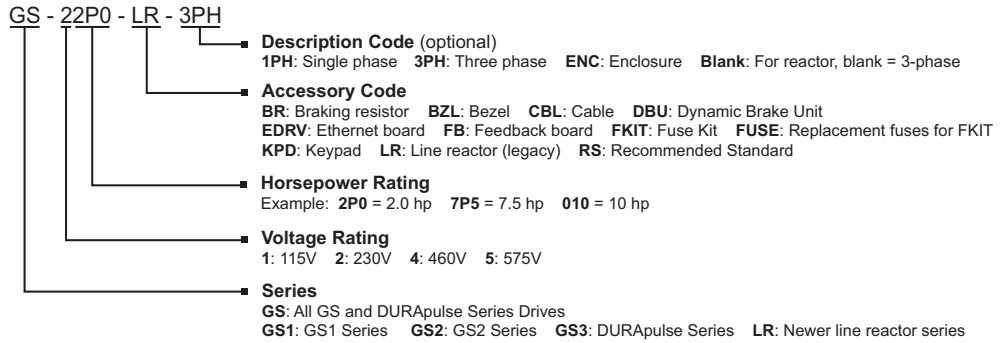

Under 20hp

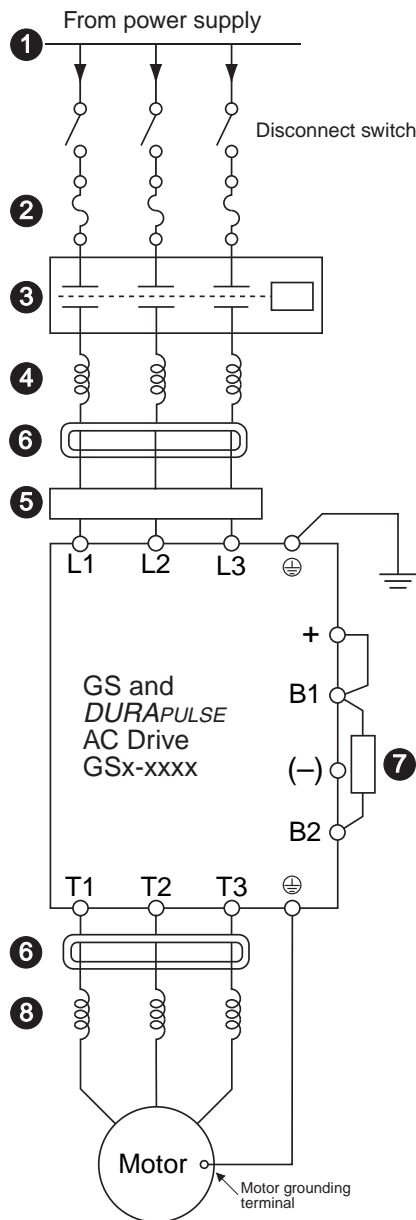

1 Power Supply

Please follow the specific power supply requirements shown in Chapter 1 and the Warning section of the applicable GS or *DURAPULSE* AC Drives User Manual.

2 Fuses (Refer to page 13–81.)

Input fuses protect the AC drive from excessive input current due to line surges, short circuits, and ground faults. They are recommended for all installations and may be required for UL-listed installations. (*AutomationDirect fuses are not available for GS1 drives.*)

3 Contactor (Optional) (Refer to the Motor Controls section.)

Do not use a contactor or disconnect switch for run/stop control of the AC drive and motor. This will reduce the operating life cycle of the AC drive. Cycling a power circuit switching device while the AC drive is in run mode should be done only in emergency situations.

4 Input Line Reactor (Optional) (Refer to page 13–50.)

Input line reactors protect the AC drive from transient overvoltage conditions, typically caused by utility capacitor switching. The input line reactor also reduces the harmonics associated with AC drives. Input line reactors are recommended for all installations.

5 EMI filter (Optional) (Refer to page 13–74.)

Input EMI filters reduce electromagnetic interference or noise on the input side of the AC drive. They are required for CE compliance and recommended for installations prone to or sensitive to electromagnetic interference. (*Separate EMI filters are not necessary for GS1 drives.*)

6 RF filter (Optional) (Refer to page 13–80.)

RF filters reduce the radio frequency interference or noise on the input or output side of the inverter.

7 Braking Resistor (Optional) (Refer to page 13–69.)

Dynamic braking allows the AC drive to produce additional braking (stopping) torque. AC drives can typically produce between 15% & 20% braking torque without the addition of any external components. The addition of optional braking may be required for applications that require rapid deceleration or high inertia loads. (*Braking resistors are not available for GS1 drives.*)

8 Output Line Reactor (Optional) (Refer to page 13–50.)

Output line reactors protect the motor insulation against AC drive short circuits and IGBT reflective wave damage, and also “smooth” the motor current waveform, allowing the motor to run cooler. They are **recommended for operating “non-inverter-duty” motors** and when the **length of wiring between the AC drive and motor exceeds 75 feet.**

GS/DURAPULSE Accessories – Overview

20hp & Over
(DURAPULSE only)

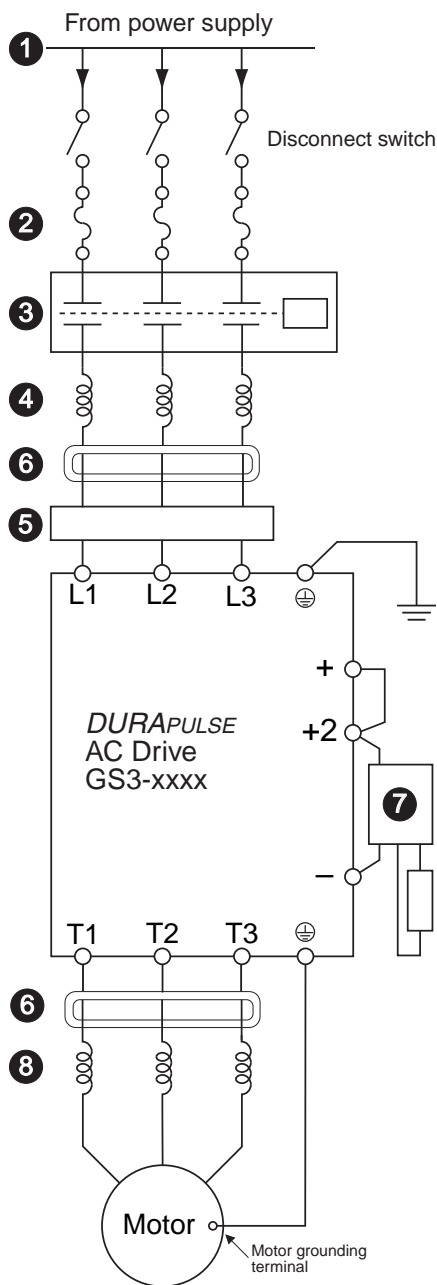

1 Power Supply

Please follow the specific power supply requirements shown in Chapter 1 of the *DURAPULSE AC Drives User Manual*.

2 Fuses (Refer to page 13–81.)

Input fuses protect the AC drive from excessive input current due to line surges, short circuits, and ground faults. They are recommended for all installations and may be required for UL-listed installations.

3 Contactor (Optional) (Refer to the Motor Controls section.)

Do not use a contactor or disconnect switch for run/stop control of the AC drive and motor. This will reduce the operating life cycle of the AC drive. Cycling a power circuit switching device while the AC drive is in run mode should be done only in emergency situations.

4 Input Line Reactor (Optional) (Refer to page 13–50.)

Input line reactors protect the AC drive from transient overvoltage conditions, typically caused by utility capacitor switching. The input line reactor also reduces the harmonics associated with AC drives. Input line reactors are recommended for all installations.

5 EMI filter (Optional) (Refer to page 13–74.)

Input EMI filters reduce electromagnetic interference or noise on the input side of the AC drive. They are required for CE compliance and recommended for installations prone to or sensitive to electromagnetic interference.

6 RF filter (Optional) (Refer to page 13–80.)

RF filters reduce the radio frequency interference or noise on the input or output side of the inverter.

7 Braking Unit & Braking Resistor (Optional) (pg 13–67)

Dynamic braking allows the AC drive to produce additional braking (stopping) torque. AC drives can typically produce between 15% & 20% braking torque without the addition of any external components. The addition of optional braking may be required for applications that require rapid deceleration or high inertia loads.

8 Output Line Reactor (Optional) (Refer to page 13–50.)

Output line reactors protect the motor insulation against AC drive short circuits and IGBT reflective wave damage, and also “smooth” the motor current waveform, allowing the motor to run cooler. They are **recommended for operating “non-inverter-duty” motors** and when the **length of wiring between the AC drive and motor exceeds 75 feet**.