

Ethernet Base Controller Modules

Ethernet Base Controller Modules (EBC)

- H2-EBC <---->
- H2-EBC100 <---->
- H2-EBC-F <---->



Specifications	H2-EBC	H2-EBC100	H2-EBC-F
Communications	10Base-T Ethernet	10/100Base-T Ethernet	10Base-FL Ethernet
Data Transfer Rate	10 Mbps max.	100 Mbps max.	10 Mbps max.
Link Distance	100 meters (328 ft)	100 meters (328 ft)	2,000 meters (6,560 ft)
Ethernet Port / Protocols	RJ45, TCP/IP, IPX	RJ45, TCP/IP, IPX, Modbus TCP/IP, DHCP, HTML configuration	ST-style fiber optic, TCP/IP, IPX
Serial Port / Protocols	RJ12, K-Sequence, ASCII IN/OUT	RJ12, K-Sequence, ASCII IN/OUT, Modbus RTU	None
Power Consumption	450 mA	300 mA	640 mA
Manufacturer	Host Automation Products, L.L.C.		

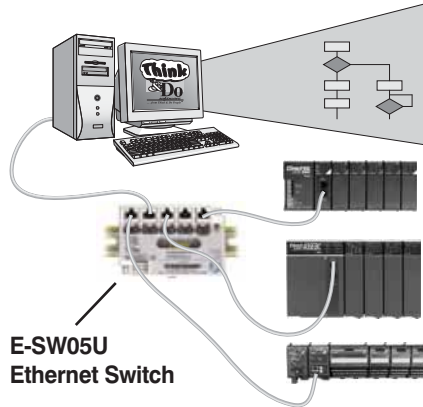

Software developers

For programmers developing custom drivers for our I/O, we offer a free Ethernet Software Development Kit (SDK). The SDK, developed and offered by Host Automation Products, L.L.C., provides a simplified API for interfacing with the H2-EBC(100) or H2-EBC-F. The software interface libraries are provided for WIN32, WIN16, and DOS operating systems. The source code is available to developers under a non-disclosure agreement. Visit the technical support link at our Web site, or go to www.hosteng.com for more information.

Off-the-shelf solutions

You can purchase PC-based control software that is ready to use with the H2-EBC(100) or H2-EBC-F module. PC-based control packages are equipped with compatible I/O device drivers, program development tools, and run-time environments. For a single-source integrated PC-based control solution that ships with everything you need to make your PC into an industrial controller, see the PC-based Control section of this catalog. Most of the software packages listed below allow you to connect serial devices, such as barcode readers, to the H2-EBC(100)'s serial port.

```

READ I/O
int HEIReadIO
(
    HEIDevice *pDevice,
    Byte *pBuffer,
    WORD BuffSize
);

WRITING I/O
int HEIWriteIO
(
    HEIDevice *pDevice,
    BYTE *pData,
    WORD SizeofData,
    BYTE *pReturnData,
    WORD
    *pSizeofReturnData
);
    
```



Easy to use, reliable and fast

The H2-EBC(100) and H2-EBC-F module plugs into the CPU slot of any DL205 I/O base and supports all DL205 discrete and analog I/O modules, the H2-SERIO and H2-CTRIO specialty modules. All EBC modules can be configured using NetEdit3, a free Windows software utility. The H2-EBC100 also supports HTML configuration.

The chart below identifies vendors that have PC-based Control products ready to control DirectLOGIC I/O, or have products to be released in the immediate future.

Vendor	Product	Web Address
AutomationDirect	KEPDirect EBC I/O Server	www.automationdirect.com
Phoenix Contact	Think & Do Live!, Think & Do Studio	www.phoenixcon.com/software
KEPware	KEPServerEX	www.kepware.com
Wonderware	InControl	www.wonderware.com
MDSI	OpenCNC	www.mdsi2.com

The D2-INST-M installation and I/O Manual covers information about DL205 I/O modules, power budgeting, and installation and wiring. This catalog does not cover CPU-slot controllers.

Use EBCs for PC-based control and for H*-ERM remote I/O slaves

The H2-EBC(100) and H2-EBC-F Ethernet Base Controller modules provide a low-cost, high-performance Ethernet link between DL205 I/O and your PC-based control system or WinPLC/DL205/ DL405 CPUs using the H*-ERM module for remote I/O. The H2-EBC100 can also be used to connect your DL205 I/O to a Modbus TCP/IP client (master). The H2-EBC module supports industry standard 10BaseT Ethernet communications. The H2-EBC100 supports industry standard 10/100BaseT Ethernet communications, and the H2-EBC-F module supports 10BaseFL (fiber optic) Ethernet communications standards. The EBC modules are compatible with TCP/IP, IPX and Modbus TCP/IP (H2-EBC100 only) protocols for flexible PC communications. EBC modules offer:

- Lower cost on your DirectLOGIC I/O system when compared to competitive I/O
- Virtually unlimited number of I/O points

Ethernet Vs. Serial Remote I/O

I/O throughput

I/O throughput is defined as the time it takes from when an output is set in the ladder logic to when its corresponding input value is equal. This includes the PLC scan time, I/O backplane update time, and I/O module response times.

Testing I/O throughput times

A test was performed by our partner, Host Automation Products, to compare the difference between H2-ERM Ethernet remote I/O and D2-RSM serial remote I/O throughput times. Host Automation Products supplies the H2-ERM, H2-EBC, H2-ECOM, etc. as well as *DirectSOFT* and *DSData Server* software.

I/O groups tested

Discrete I/O - D2-16TD1-2 discrete outputs of slot 2 are tied to the D2-16ND3-2 discrete inputs of slot 0.

Analog I/O - F2-02DAS-2 analog output channel 1 is tied to the F2-04AD-2 analog input channel 1 of slot 3. The analog values were scaled from the full 16-bit range down to 12 bit range.

Each group was run independently through the following cycle 256 times:

- Step 1: Set all outputs to OFF for a random number of scans
- Step 2: Set all outputs to a random value for a random number of scans
- Step 3: Set all outputs to ON for a random number of scans
- Step 4: Set all outputs to a random value for a random number of scans

Since these four steps are repeated 256 times, there are actually 1,024 samples of I/O throughput.

Test results

The results are listed in the tables at the right. As the number of H2-ERM slaves and I/O points increase, the I/O throughput times will remain flat until 64 analog inputs, 64 analog outputs, or 1,024 discrete I/O points are exceeded. As the number of D2-RSM slaves and I/O points increase, the I/O throughput times increase proportionally.

H2-ERM / H2-EBC Ethernet Remote I/O System



D2-RSM / D2-RSSS Serial Remote I/O System

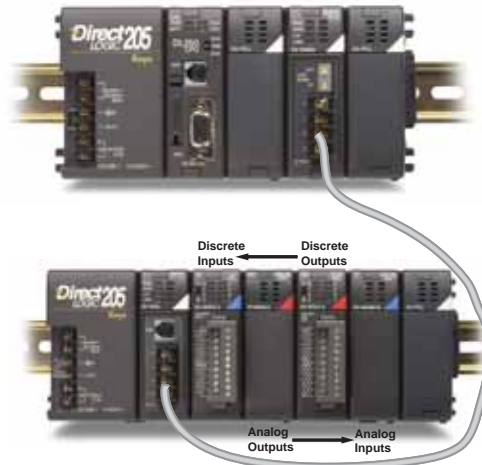

Discrete I/O Test	I/O Throughput Times			
Remote I/O System	Min.	Max.	Avg.	Std. Dev.
H2-ERM / H2-EBC	45ms	71ms	53.32ms	6.14ms
D2-RSM / D2-RSSS	36ms	56ms	42.29ms	5.81ms

Analog I/O Test	I/O Throughput Times			
Remote I/O System	Min.	Max.	Avg.	Std. Dev.
H2-ERM / H2-EBC	46ms	113ms	62.94ms	14.48ms
D2-RSM / D2-RSSS	64ms	321ms	117.38ms	37.44ms