

# Hammond Transformers



Get years of reliable service from a quality transformer at a practical price

## HPS Imperator™ control transformers for industrial applications

HPS Imperator control transformers from Hammond are specifically designed for high inrush applications requiring reliable output voltage stability. Designed to meet industrial applications where electromagnetic devices such as relays, solenoids, etc. are used, they maximize inrush capability and output voltage regulation when electromagnetic devices are initially energized.

HPS Imperator control transformers use Mylar, Nomex and other high-quality insulating materials. Insulation is used to electrically insulate turn-to-turn windings, layer-to-layer windings, primary-to-secondary windings and ground. These transformers are vacuum impregnated with VT polyester resin and oven-cured, which seals the surface and eliminates moisture. Filling the entire unit provides a strong mechanical bond and offers protection from the environment. This design utilizes superior insulation systems and is constructed with high quality silicon steel laminations, which provide optimum performance and reliability.

The custom injection-molded cover, with its unique fin-shaped design, provides excellent cooling properties while protecting the coils and terminations from moisture, dirt and other industrial airborne contaminants.

The heavy steel mounting feet are welded to the core, providing maximum strength and low noise in a compact design.

The HPS Imperator's unique terminal block design (patent pending) allows for the quick and easy installation of standard secondary or optional primary 13/32" x 1 1/2" midget/type CC fuse clips on every unit.

This is the simplest and most inexpensive fusing installation provided on any industrial control transformer in the market today.

The windings and internal terminations of the HPS Imperator are encapsulated, which protects them from moisture, dirt and other airborne contaminants. The custom molded coil covers with their unique 'fin shaped' design combine superior transformer cooling properties with a clean bold look.

The HPS Imperator utilizes custom serrated terminals, in combination with standard SEMS washer screws making assembly easier and quicker to install; and provides superior connection strength when connecting with bare, solid, or stranded wire. It also allows for ring or spade termination connectors.

## HPS Fortress™ commercial potted transformers

The HPS Fortress commercial potted transformers provide an innovative design with commercial applications where quality, ease of installation, and low cost are key.

All Fortress units are encapsulated with electrical grade silica sand and resin compounds, which completely enclose the core and coil to seal out moisture, airborne contaminants and eliminates corrosion and deterioration.

## Superior quality and value

- Compact, efficient design
- Easy installation and hook-up
- Inexpensive while maintaining superior quality in materials and workmanship
- Wall mounting

## Applications

- Shopping centers
- Schools
- Sports complexes
- Office buildings
- Lighting

# Control Transformer Selection

## Control transformer selection

To select the proper transformer, you must first determine three characteristics of the load circuit. They are: total steady-state (sealed) VA, total inrush VA, and inrush load power factor.

**Total steady-state “sealed” VA** is the total amount of VA that the transformer must supply to the load circuit for an extended length of time. Calculate by adding the total steady-state VA of all devices in your control circuit. *(The operating VA data for the devices should be available from the manufacturers.)*

The **inrush VA** is the amount of VA that the transformer must supply for all components in the control circuit that are energized together. Consideration for the start-up sequence may be required. *(Inrush VA data should be obtained from the device manufacturers.)*

The **inrush load power factor** is difficult to determine without detailed vector analysis of all the control components. In the absence of such information, we recommend that a 40% power factor be utilized.

## Six easy steps

Once the three load circuit variables have been determined, follow these steps to select the proper transformer.

1. Determine your primary (supply) and secondary (output) voltage requirements, as well as the required frequency (i.e. 60 Hz).
2. Calculate the total sealed VA of your circuit by adding the total sealed VA of all devices in the control circuit.
3. Calculate the inrush VA by adding the inrush VA of all components being energized together. Remember to add the sealed VA of all components that do not have inrush VA (lamps, timers, etc.), as they do present a load to the transformer during maximum inrush. If the inrush for your components is unknown, assume a 40% inrush power factor.

$$A \quad \text{Total Inrush VA} = \sqrt{(\text{VA sealed})^2 + (\text{VA inrush})^2}$$

or

$$B \quad \text{Total Inrush VA} = \text{VA Sealed} + \text{VA Inrush}$$

4. Calculate the total inrush VA using one of two methods:  
**Method B will result in slightly larger transformer selected.**
5. If the nominal supply voltage does not fluctuate more than 5%, then reference the 90% secondary voltage column in the Regulation Data Table for the correct VA rating.  
If the supply voltage varies up to 10%, the 95% secondary voltage column should be used to size the transformer. The 85% secondary voltage column gives minimum values for proper electromagnetic device operation and should only be used as a reference.

6. Using the regulation data table below, select the appropriate VA rated transformer:
  - A. With a continuous VA rating that is equal to or greater than the value in Step 2.
  - B. With a maximum inrush VA equal to or greater than the value obtained in Step 4.

*Note: See over-current protection chart for transformers at the end of this section.*

HPS Imperator Transformer Regulation Data Table			
Continuous VA Transformer Nameplate	Inrush VA @ 40% Power Factor		
	85% Secondary Voltage	90% Secondary Voltage	95% Secondary Voltage
50	330	259	192
75	350	258	170
100	620	467	321
150	895	699	512
250	1596	1229	880
350	2464	1889	1345
500	3939	2854	1819
750	6422	4778	3228
1000	9842	7102	4530
1500	12797	9018	5489

*Note: It is recommended that a control transformer be sized at a 40% power factor. Some components in a circuit, such as electromagnetic devices, typically operate at that level due to their inherently lower power factor. Selecting a transformer at 40% power factor will more than adequately size the unit for all the various loads in the circuit.*

# HPS Imperator™ 240x120 / 24x12 VAC Control Transformers Specifications

## Features

- 600V class, machine tool rated industrial control transformers
- 50/60 Hertz
- VA range from 50 VA up to 1000 VA
- Constructed with high quality silicon steel laminations that provide optimum performance and reliability
- Encapsulated coils, encased in a custom injection molded cover, protect coils and terminations from moisture, dirt and other industrial airborne contaminants.

- Terminated with #8/32 slot/Phillips terminal screws complete with SEMS washer (suitable for 18 AWG to 14 AWG solid or 14 AWG stranded wire).
- Insulation system:
  - 50 - 150VA, temperature rise 55°C (131°F), insulation class 105°C (221°F),
  - 250 - 1000VA, temperature rise 80°C (176°F), insulation class 130°C (266°F)
- SEMS (standard machine screw with lock washer) standard (not on PH750PG or PH1000PG)
- Standard secondary fuse kits utilizing 13/32" x 1 1/2" midget class CC fuse clips included with all transformers.

Fuses are not included. (See Edison fuse section for HCTR fuses.)

- Optional primary fuse kits available utilizing 13/32" x 1 1/2" midget class CC fuse clips
- Optional finger-safe terminal covers
- LIFETIME warranty (limited to mfg. defects)

## Agency Approvals

- UL Listed (approved for U.S. and Canada) File E50394
- CE Mark standard on all units
- RoHS Compliant



### HPS Imperator 240x120/24x12 Control Transformer Specifications

Part Number	Wt/Lbs	Price	Volt-Amp Rating*	Mtg. Fig.	Output Current Amps	Primary Voltage (50/60Hz)	Secondary Voltage	Impedance %		Total Heat Dissipation (Watts)**
								VA	%z	
PH50PG	3.5	<-->	50	A	0.417/2.08	120x240 115x230 110x220	12x24 11.5x23 11x22	50	8.3	11
PH75PG	3.5	<-->	75	A	6.25/3.13			75	8.7	14
PH100PG	4.5	<-->	100	A	8.33/4.17			100	8.4	14
PH150PG	5.7	<-->	150	B	12.5/6.25			150	8.0	18
PH250PG	7.5	<-->	250	B	20.8/10.4			250	7.8	29
PH350PG	10.1	<-->	350	B	29.2/14.6			350	7.0	33
PH500PG	14.2	<-->	500	B	41.7/20.8			500	5.0	40
PH750PG	16.6	<-->	750	B	62.5/31.3			750	4.9	54
PH1000PG	23.6	<-->	1000	B	83.3/41.7			1000	3.9	69

Note: \*VA capacity rated at the output of the transformer.

\*\* Heat dissipation calculated based on full rated load on transformer.

## Dimensions

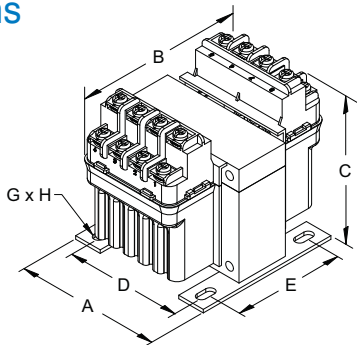

FIGURE A (100VA and less)

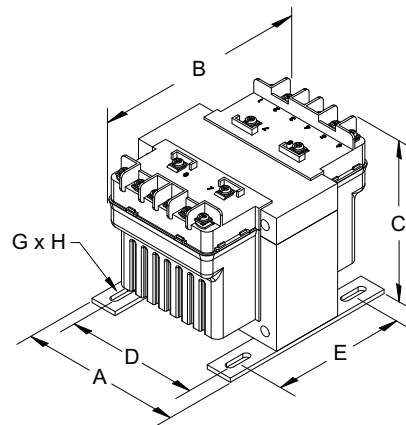

FIGURE B (150VA to 1000VA)

### HPS Imperator 240x120/24x12 Control Transformer Dimensions

Part Number	Mtg. Fig.	Overall Dimensions inches (mm)			Mounting Centers inches (mm)		Mounting Slot inches (mm)	Height with Finger Guard, inches (mm)	Depth with Finger Guard inches (mm)
		A	B	C	D	E	G X H		
PH50PG	A	3.00 (76.2)	4.38 (111.3)	3.19 (81.0)	2.50 (63.5)	2.25 (57.2)	0.22 x 0.44 (5.6 x 11.2)	4.00 (101.6)	5.82 (147.8)
PH75PG	A	3.25 (82.6)	3.88 (98.5)	3.56 (90.4)	2.63 (66.8)	2.50 (63.5)	0.22 x 0.44 (5.6 x 11.2)	4.37 (111.0)	5.32 (135.1)
PH100PG	A	3.25 (82.6)	4.19 (106.4)	3.63 (92.2)	2.63 (66.8)	2.63 (66.8)	0.22 x 0.44 (5.6 x 11.2)	4.44 (112.8)	5.63 (143.0)
PH150PG	B	4.00 (101.6)	4.94 (125.5)	3.81 (96.8)	3.38 (85.9)	2.75 (69.9)	0.22 x 0.75 (5.6 x 19.1)	4.31 (109.5)	6.44 (163.6)
PH250PG	B	4.50 (114.3)	5.44 (138.2)	3.81 (96.8)	3.75 (95.3)	3.13 (79.5)	0.22 x 0.75 (5.6 x 19.1)	4.31 (109.5)	6.94 (176.3)
PH350PG	B	4.50 (114.3)	5.19 (131.8)	4.44 (112.8)	3.75 (95.3)	3.75 (95.3)	0.22 x 0.75 (5.6 x 19.1)	4.94 (125.5)	6.69 (169.9)
PH500PG	B	4.75 (120.7)	5.94 (150.9)	4.31 (109.5)	4.06 (103.1)	3.81 (96.8)	0.31 x 0.94 (7.9 x 23.9)	4.81 (122.2)	7.44 (189.0)
PH750PG	B	5.13 (130.3)	6.69 (169.9)	4.31 (109.5)	4.38 (111.3)	4.31 (109.5)	0.31 x 0.81 (7.9 x 20.6)	4.81 (122.2)	8.19 (208.1)
PH1000PG	B	5.25 (133.4)	6.81 (173.0)	4.94 (125.5)	4.50 (114.3)	4.44 (112.8)	0.31 x 0.81 (7.9 x 20.6)	5.44 (138.2)	8.31 (211.1)

Note: All dimensions are ±0.06 inches unless otherwise noted.

# HPS Imperator™ 240x120 / 24x12 VAC Control Transformers Wiring Specifications

## Wiring

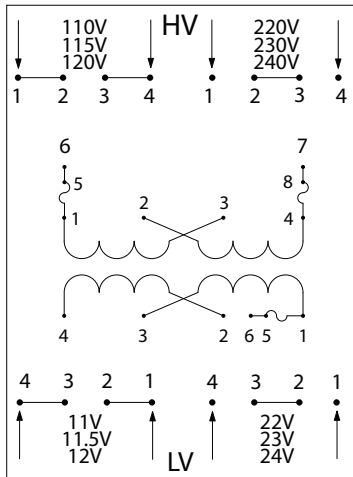

### PH\*\*\*PG Schematic for 50, 75 and 100VA Units

High Voltage (HV) (Primary Volts)	Install Supplied Links Between Terminals	Supply Lines Connect To	Install Fuse Clips To
120 115 110	1-2, 3-4	1, 4	Unfused
240 230 220	2-3	1, 4	Unfused
120 115 110	1-2, 3-4	6, 7	1-5, 4-8
240 230 220	2-3	6, 7	1-5, 4-8
Low Voltage (LV) (Secondary Volts)	Install Supplied Links Between Terminals	Load Lines Connect To	Install Fuse Clips To
12 11.5 11	3-4, 1-2	1, 4	Unfused
24 23 22	2-3	1, 4	Unfused
12 11.5 11	3-4, 1-2	4, 6	1-5
24 23 22	2-3	4, 6	1-5

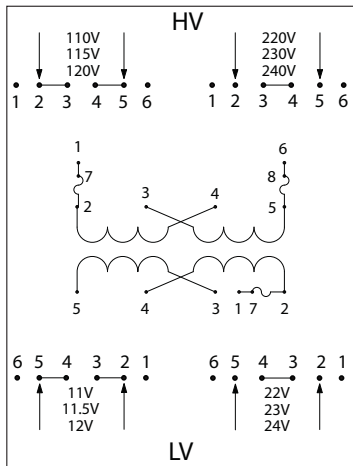

### PH\*\*\*PG Schematic for 150VA to 500VA Units

High Voltage (HV) (Primary Volts)	Install Supplied Links Between Terminals	Supply Lines Connect To	Install Fuse Clips To
120 115 110	2-3, 4-5	2, 5	Unfused
240 230 220	3-4	2, 5	Unfused
120 115 110	2-3, 4-5	1, 6	2-7, 5-8
240 230 220	3-4	1, 6	2-7, 5-8
Low Voltage (LV) (Secondary Volts)	Install Supplied Links Between Terminals	Load Lines Connect To	Install Fuse Clips To
12 11.5 11	4-5, 2-3	2, 5	Unfused
24 23 22	3-4	2, 5	Unfused
12 11.5 11	4-5, 2-3	1, 5	2-7
24 23 22	3-4	1, 5	2-7

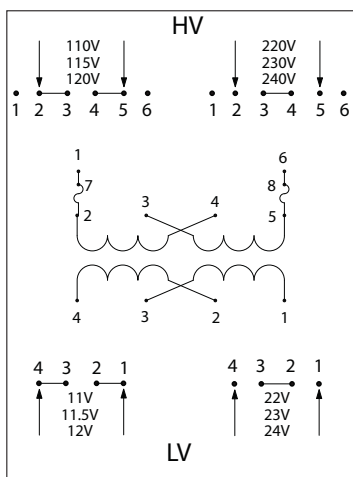

### PH\*\*\*PG Schematic for 750VA and 1000VA Units

High Voltage (HV) (Primary Volts)	Install Supplied Links Between Terminals	Supply Lines Connect To	Install Fuse Clips To
120 115 110	2-3, 4-5	2, 5	Unfused
240 230 220	3-4	2, 5	Unfused
120 115 110	2-3, 4-5	1, 6	2-7, 5-8
240 230 220	3-4	1, 6	2-7, 5-8
Low Voltage (LV) (Secondary Volts)	Install Supplied Links Between Terminals	Load Lines Connect To	Install Fuse Clips To
12 11.5 11	3-4, 1-2	1, 4	Unfused
24 23 22	2-3	1, 4	Unfused

Note: secondary fuse clips not available on PH750PG or PH1000PG.

#### Notes

1. FUSES NOT INCLUDED (see Edison fuse section for HCTR fuses).
2. Jumper links to make primary/secondary series/parallel connections supplied, but not installed.
3. Secondary fuse clips supplied but not installed. Order fuses and primary fuse clips separately.