

# HPS Imperator™ 480x240 / 240x120 VAC Control Transformers Specifications

## Features

- 600V class, machine tool rated industrial control transformers
- 50/60 Hertz
- VA range from 50 VA up to 1500 VA
- Constructed with high quality silicon steel laminations that provide optimum performance and reliability
- Encapsulated coils, encased in a custom injection molded cover, protect coils and terminations from moisture, dirt and other industrial airborne contaminants.
- Temperature Range: -20°C (-4°F) to 40°C (104°F)

- Terminated with #8/32 slot/Phillips terminal screws complete with SEMS washer (suitable for 18 AWG to 14 AWG solid or 14 AWG stranded wire)
- Insulation system:
  - 50 - 150VA, temperature rise 55°C (131°F), insulation class 105°C (221°F),
  - 250 - 1500VA, temperature rise 80°C (176°F), insulation class 130°C (266°F)
- SEMS (standard machine screw with lock washer) standard
- Standard secondary fuse kits utilizing 13/32" x 1 1/2" fuse clips included with all transformers. Fuses are not included. (See Edison fuse section for MEN fuses.)

- Optional primary fuse kits available utilizing 13/32" x 1 1/2" fuse clips (See Edison fuse section for HCTR fuses.)
- Optional finger-safe terminal covers
- LIFETIME warranty (limited to mfg. defects)

## Agency Approvals

- UL Listed (approved for U.S. and Canada) File E50394
- CE Mark standard on all units
- RoHS Compliant



HPS Imperator 480x240/240x120 Control Transformer Specifications											
Part Number	Price	Volt-Amp Rating*	Mtg. Fig.	Primary Voltage (50/60Hz)	Secondary Voltage (Nominal)	Output Current (Amps) 120/240		Impedance %		Total Heat Dissipation (Watts)**	Wt/Lbs
						VA	%z				
PH50MQMJ	<--->	50	A	240x480 230x460 220x440	120x240 115x230 110x220	0.42/0.21	50	8.3	11	3.50	
PH75MQMJ	<--->	75	A			0.63/0.31	75	8.7	14	3.54	
PH100MQMJ	<--->	100	A			0.83/0.42	100	8.4	14	4.50	
PH150MQMJ	<--->	150	B			1.25/0.63	150	8.0	18	5.70	
PH250MQMJ	<--->	250	B			2.08/1.04	250	7.8	29	7.50	
PH350MQMJ	<--->	350	B			2.92/1.46	350	7.0	33	10.1	
PH500MQMJ	<--->	500	B			4.17/2.08	500	5.0	40	14.2	
PH750MQMJ	<--->	750	B			6.25/3.13	750	4.9	54	16.6	
PH1000MQMJ	<--->	1000	B			8.33/4.17	1000	3.9	69	23.6	
PH1500MQMJ	<--->	1500	B			12.5/6.25	1500	3.9	101	34.0	

Note: \*VA capacity rated at the output of the transformer.  
 \*\* Heat dissipation calculated based on full rated load on transformer.

## Dimensions

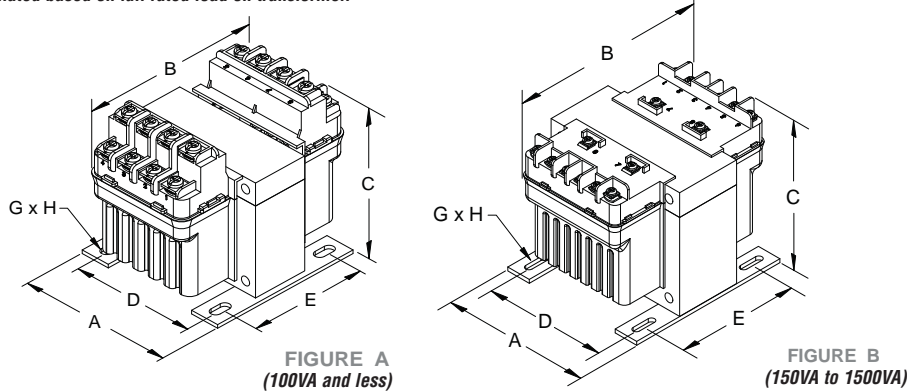

HPS Imperator 480x240/240x120 Control Transformer Dimensions									
Part Number	Mtg. Fig.	Overall Dimensions inches (mm)			Mounting Centers inches (mm)		Mounting Slot inches (mm)	Height with Finger Guard inches (mm)	Depth with Finger Guard inches (mm)
		A	B	C	D	E	G x H		
PH50MQMJ	A	3.00 (76.2)	4.38 (111.3)	3.19 (81.0)	2.50 (63.5)	2.25 (57.2)	0.22 x 0.44 (5.6 x 11.2)	4.00 (101.6)	5.82 (147.8)
PH75MQMJ	A	3.25 (82.6)	3.88 (98.9)	3.56 (90.4)	2.63 (66.8)	2.50 (63.5)	0.22 x 0.44 (5.6 x 11.2)	4.37 (111.0)	5.32 (135.1)
PH100MQMJ	A	3.25 (82.6)	4.19 (106.4)	3.63 (92.2)	2.63 (66.8)	2.63 (66.8)	0.22 x 0.44 (5.6 x 11.2)	4.44 (112.8)	5.63 (143.0)
PH150MQMJ	B	4.00 (101.6)	4.94 (125.5)	3.81 (96.8)	3.38 (85.9)	2.75 (69.9)	0.22 x 0.75 (5.6 x 19.1)	4.31 (109.5)	6.44 (163.6)
PH250MQMJ	B	4.50 (114.3)	5.44 (138.2)	3.81 (96.8)	3.75 (95.3)	3.13 (79.5)	0.22 x 0.75 (5.6 x 19.1)	4.31 (109.5)	6.94 (176.3)
PH350MQMJ	B	4.50 (114.3)	5.19 (131.8)	4.44 (112.8)	3.75 (95.3)	3.75 (95.3)	0.22 x 0.75 (5.6 x 19.1)	4.94 (125.5)	6.69 (169.9)
PH500MQMJ	B	4.75 (120.7)	5.94 (150.9)	4.31 (109.5)	4.06 (103.1)	3.81 (96.8)	0.31 x 0.94 (7.9 x 23.9)	4.81 (122.2)	7.44 (189.0)
PH750MQMJ	B	5.13 (130.3)	6.69 (169.9)	4.31 (109.5)	4.38 (111.3)	4.31 (109.5)	0.31 x 0.81 (7.9 x 20.6)	4.81 (122.2)	8.19 (208.1)
PH1000MQMJ	B	5.25 (133.4)	6.81 (173.0)	4.94 (125.5)	4.50 (114.3)	4.44 (112.8)	0.31 x 0.81 (7.9 x 20.6)	5.44 (138.2)	8.31 (211.1)
PH1500MQMJ	B	5.25 (133.4)	8.19 (208.0)	4.94 (125.5)	4.50 (114.3)	6.06 (153.9)	0.38 x 1.00 (9.7 x 25.4)	5.44 (138.2)	9.69 (246.1)

Note: All dimensions are ±0.06 inches unless otherwise noted.

# HPS Imperator™ 480x240 / 240x120 VAC Control Transformers Wiring Specifications

## Wiring

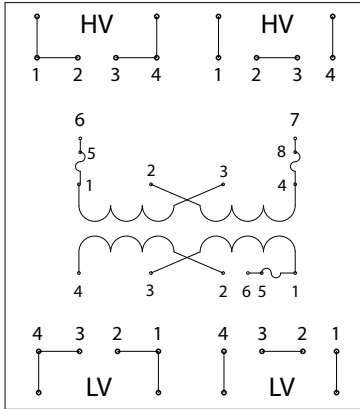

### PH\*\*\*MQMJ Schematic for 50, 75 and 100VA Units

High Voltage (HV) (Primary Volts)	Install Jumpers/Links Between Lines	Supply Lines Connect To	Install Fuse Clips To
240 230 220	1-2, 3-4	1, 4	
480 460 440	2-3	1, 4	
240 230 220	1-2, 3-4	6, 7	1-5, 4-8
480 460 440	2-3	6, 7	1-5, 4-8

Low Voltage (LV) (Secondary Volts)	Install Jumpers/Links Between Lines	Load Lines Connect To	Install Fuse Clips To
120 115 110	3-4, 1-2	1, 4	
240 230 220	2-3	1, 4	
120 115 110	3-4, 1-2	4, 6	1-5
240 230 220	2-3	4, 6	1-5

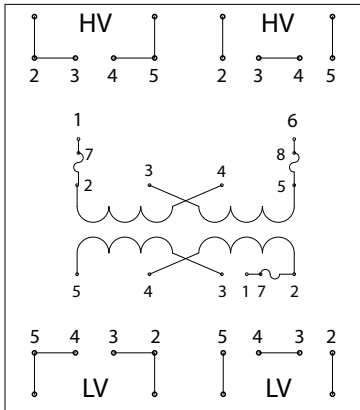

### PH\*\*\*MQMJ Schematic for 150VA to 1500VA Units

High Voltage (HV) (Primary Volts)	Install Jumpers/Links Between Lines	Supply Lines Connect To	Install Fuse Clips To
240 230 220	2-3, 4-5	2, 5	
480 460 440	3-4	2, 5	
240 230 220	2-3, 4-5	1, 6	2-7, 5-8
480 460 440	3-4	1, 6	2-7, 5-8

Low Voltage (LV) (Secondary Volts)	Install Jumpers/Links Between Lines	Load Lines Connect To	Install Fuse Clips To
120 115 110	4-5, 2-3	2, 5	
240 230 220	3-4	2, 5	
120 115 110	4-5, 2-3	1, 5	2-7
240 230 220	3-4	1, 5	2-7

#### Notes

- FUSES NOT INCLUDED (see Edison fuse section for fuses).
- Secondary fuse clips supplied but not installed. Order fuses and primary fuse clips separately.
- Jumper links to make primary/secondary series/parallel connections supplied, but not installed.

# Control Transformer Selection

## Control transformer selection

To select the proper transformer, you must first determine three characteristics of the load circuit. They are: total steady-state (sealed) VA, total inrush VA, and inrush load power factor.

**Total steady-state “sealed” VA** is the total amount of VA that the transformer must supply to the load circuit for an extended length of time. Calculate by adding the total steady-state VA of all devices in your control circuit. (*The operating VA data for the devices should be available from the manufacturers.*)

The **inrush VA** is the amount of VA that the transformer must supply for all components in the control circuit that are energized together. Consideration for the start-up sequence may be required. (*Inrush VA data should be obtained from the device manufacturers.*)

The **inrush load power factor** is difficult to determine without detailed vector analysis of all the control components. In the absence of such information, we recommend that a 40% power factor be utilized.

## Six easy steps

Once the three load circuit variables have been determined, follow these steps to select the proper transformer.

1. Determine your primary (supply) and secondary (output) voltage requirements, as well as the required frequency (i.e. 60 Hz).
2. Calculate the total sealed VA of your circuit by adding the total sealed VA of all devices in the control circuit.
3. Calculate the inrush VA by adding the inrush VA of all components being energized together. Remember to add the sealed VA of all components that do not have inrush VA (lamps, timers, etc.), as they do present a load to the transformer during maximum inrush. If the inrush for your components is unknown, assume a 40% inrush power factor.
4. Calculate the total inrush VA using one of two methods:

$$\begin{array}{l}
 \text{A} \quad \text{Total Inrush VA} = \frac{\sqrt{(\text{VA sealed})^2 + (\text{VA inrush})^2}}{\text{or}} \\
 \text{B} \quad \text{Total Inrush VA} = \text{VA Sealed} + \text{VA Inrush}
 \end{array}$$

**Method B will result in slightly larger transformer selected.**

5. If the nominal supply voltage does not fluctuate more than 5%, then reference the 90% secondary voltage column in the Regulation Data Table for the correct VA rating. If the supply voltage varies up to 10%, the 95% secondary voltage column should be used to size the transformer. The 85% secondary voltage column gives minimum values for proper electromagnetic device operation and should only be used as a reference.
6. Using the regulation data table below, select the appropriate VA

rated transformer:

- A. With a continuous VA rating that is equal to or greater than the value in Step 2.
- B. With a maximum inrush VA equal to or greater than the value obtained in Step 4.

**Note:** See over-current protection chart for transformers at the end of this section.

HPS Imperator Transformer Regulation Data Table			
Continuous VA Transformer Nameplate	Inrush VA @ 40% Power Factor		
	85% Secondary Voltage	90% Secondary Voltage	95% Secondary Voltage
50	330	259	192
75	350	258	170
100	620	467	321
150	895	699	512
250	1596	1229	880
350	2464	1889	1345
500	3939	2854	1819
750	6422	4778	3228
1000	9842	7102	4530
1500	12797	9018	5489

**Note:** It is recommended that a control transformer be sized at a 40% power factor. Some components in a circuit, such as electromagnetic devices, typically operate at that level due to their inherently lower power factor. Selecting a transformer at 40% power factor will more than adequately size the unit for all the various loads in the circuit.

Voltage regulation in transformers is the difference between the “No-Load voltage” and the “Full-Load voltage”. This is expressed in terms of percentage.

$$\text{Regulation Percentage} = \frac{E_{\text{No-Load}} - E_{\text{Full Load}}}{E_{\text{Full Load}}} (100\%)$$

The secondary voltage (nominal) listed in these pages are at Full-Load, meaning the point at which the transformer is operating at maximum permissible secondary current. No-Load voltage can increase 4 to 6%.

**Warning:** Secondary voltages of transformers may damage some loads. For example, a transformer connected as 480/120 Volt but applied 495 Volt primary can produce at No-Load a voltage of 134 Volts which will damage the inputs of a PLC D0-06AA, whose maximum input voltage is 132 Volt. Notice that the current of D0-06AA input is 10mA, making it very close to No-Load.



Company Information

Systems Overview

Programmable Controllers

Field I/O

Software

C-more & other HMI

Drives

Soft Starters

Motors & Gearbox

Steppers/ Servos

Motor Controls

Proximity Sensors

Photo Sensors

Limit Switches

Encoders

Current Sensors

Pressure Sensors

Temperature Sensors

Pushbuttons/ Lights

Process

Relays/ Timers

Comm.

Terminal Blocks & Wiring

Power

Circuit Protection

Enclosures

Tools

Pneumatics

Safety

Appendix

Product Index

Part # Index

# HPS Imperator™ Transformers Accessories – Terminal Covers and Fuse Kits

## Finger-safe terminal covers

These one-piece molded terminal covers are a quick and easy way to provide safety and protection in the workplace. They protect operators from potential shock hazards and guard against accidental contact with the fuses.

## Fuse Kits

These optional primary side fuse kits contain four fuse clips, four mounting screws, and complete instructions.

The table below makes it easy to choose the correct terminal covers and fuse kits for your Hammond control transformer.

Transformer	Finger-Safe Terminal Covers				Primary Side Fuse Kits		
Part Number	Part Number	Pcs/Pkg	Price	Description	Part Number	Pcs/Pkg	Price
PH50MQMJ PH50PG	FG1	1 cover	<--->	Finger-safe cover for MQMJ and PG series 50VA unfused control transformers. Cover fits primary side or secondary side.	PFK1	4 fuse clips, 4 mounting screws	<--->
	FGF1	1 cover	<--->	Finger-safe cover for MQMJ and PG series 50VA unfused control transformers. Cover fits primary side or secondary side.			
PH75MQMJ PH75PG PH100MQMJ PH100PG	FG2	1 cover	<--->	Finger-safe cover for all 75VA, all 100VA, PH50MLI and PH50MGJ fused control transformers. Cover fits primary or secondary side.	PFK2	4 fuse clips, 4 mounting screws	<--->
	FGF2	1 cover	<--->	Finger-safe cover for 75VA, all 100VA, PH50MLI and PH50MGJ unfused control transformers. Cover fits primary or secondary side.			
PH150MQMJ PH150PG PH250MQMJ PH250PG	FG3	1 cover	<--->	Finger-safe cover for all 150VA, PH250MQMJ and PH250PG fused and unfused control transformers. Cover fits primary or secondary side.	PFK3	4 fuse clips, 4 mounting screws	<--->
PH350MQMJ PH350PG PH500MQMJ PH500PG PH750MQMJ	FG4	1 cover	<--->	Finger-safe cover for all 350VA, 500VA, 750VA, 1000VA, 1500VA transformers and the PH250MLI and PH250MGJ transformers fused and unfused control transformers. Cover fits primary or secondary side.	PFK4	4 fuse clips, 4 mounting screws 1 cover	<--->
PH1000MQMJ PH750PG PH1500MQMJ PH1000PG	FG5	1 cover	<--->	Finger-safe cover for all 750VA, 1000VA, 1500VA fused and unfused control transformers. Cover fits primary or secondary side.	PFK5	4 fuse clips, 4 mounting screws 1 cover	<--->
PH50MLI PH50MGJ	FG2	1 cover	<--->	Finger-safe cover for all 75VA, all 100VA, PH50MLI and PH50MGJ unfused control transformers. Cover fits primary or secondary side.	PFK6	4 fuse clips, 4 mounting screws 1 jumper wire	<--->
	FGF2	1 cover	<--->	Finger-safe cover for 75VA, all 100VA, PH50MLI and PH50MGJ fused control transformers. Cover fits primary or secondary side.			
PH100MLI PH75MGJ PH100MGJ	FG2	1 cover	<--->	Finger-safe cover for all 75VA, all 100VA, PH50MLI and PH50MGJ unfused control transformers. Cover fits primary or secondary side.	PFK7	4 fuse clips, 4 mounting screws 1 jumper wire	<--->
	FGF2	1 cover	<--->	Finger-safe cover for 75VA, all 100VA, PH50MLI and PH50MGJ fused control transformers. Cover fits primary or secondary side.			
PH150MGJ	FG3	1 cover	<--->	Finger-safe cover for all 150VA, PH250MQMJ and PH250PG fused and unfused control transformers. Cover fits primary or secondary side.			
PH250MLI PH250MGJ	FG4	1 cover	<--->	Finger-safe cover for all 350VA, 500VA, 750VA, 1000VA, 1500VA transformers and the PH250MLI and PH250MGJ transformers fused and unfused. Cover fits primary or secondary side.			
PH350MLI PH350MGJ PH500MLI PH500MGJ	FG4	1 cover	<--->	Finger-safe cover for all 350VA, 500VA, 750VA, 1000VA, 1500VA transformers and the PH250MLI and PH250MGJ transformers fused and unfused. Cover fits primary or secondary side.			

1. Torque all terminal screws between 12 and 14 in-lbs.
2. For all bare wire connections, the recommended wire size range is 18 AWG to 14 AWG for solid wire, and 14 AWG for stranded. A ring or spade connector must be used if using a wire size outside the range listed above.
3. Ensure mounting screws used for transformer installation (not supplied) are properly sized for transformer weight.
4. When mounting fuse clips, remove the appropriate captive washer screw(s) from terminal block and install fuse clip(s) and new terminal screw(s).
5. Please refer to wiring instructions included with the Hammond control transformer for connection details.

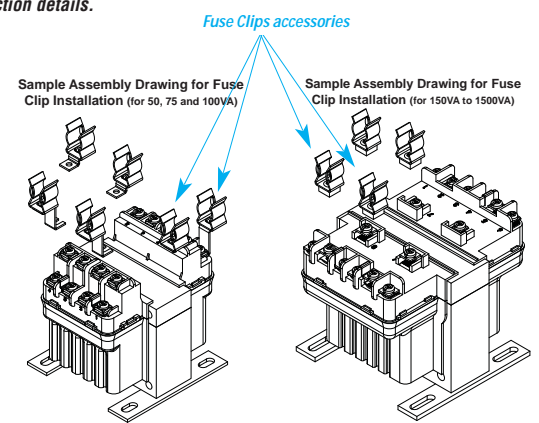
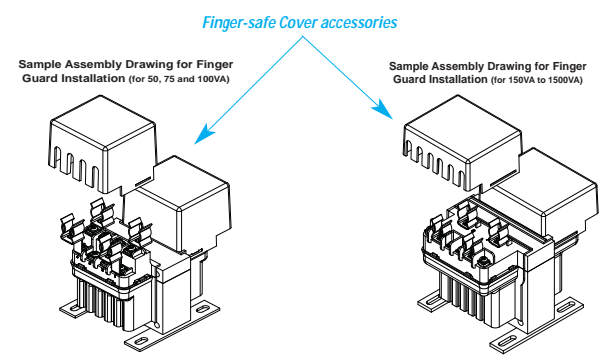

Standard secondary fuse kits utilizing 13/32" x 1 1/2" fuse clips included with all transformers. Fuses are not included. (See Edison fuse section for MEN fuses.)