



Company Information

Systems Overview

Programmable Controllers

Field I/O

Software

C-more & other HMI

Drives

Soft Starters

Motors & Gearbox

Steppers/ Servos

Motor Controls

Proximity Sensors

Photo Sensors

Limit Switches

Encoders

Current Sensors

Pressure Sensors

Temperature Sensors

Pushbuttons/ Lights

Process

Relays/ Timers

Comm.

Terminal Blocks & Wiring

Power

Circuit Protection

Enclosures

Tools

Pneumatics

Safety

Appendix

Product Index

Part # Index

AutomationDirect AC Motors Selection Overview

EPAct, High and Premium Efficiency - What does it all mean?

EPAct (1992)

In 1992, the U.S. Congress passed legislation requiring that general purpose Design A & B motors meet minimum efficiency requirements, and this legislation was called the Energy Policy Act of 1992. Previously, there had been no U.S. standards set forth for motor energy efficiency. Since 1997 (when EPAct '92 was first enforced), two-, four-, and six-pole general purpose Design A & B motors had to meet EPAct guidelines. Since then, most general purpose motors manufactured and/or sold in the U.S. have met these requirements.

Premium Efficiency (EISA 2007)

In December 2010, a new level of energy efficiency mandate went into effect. The Energy Independence and Security Act of 2007 mandated that all AC industrial motors as described below must meet Premium Efficiency standards. The NEMA trade group was instrumental in getting this legislation passed, so many people refer to the high efficiency motors by their nickname – NEMA Premium®. All applicable motors manufactured or imported into the U.S. after December 2010 must meet the Premium Efficiency guidelines.

Motors Covered Under EISA 2007 (Premium Efficiency Mandate)	
Included – must meet the new Premium Efficiency standards – Industrial AC electric squirrel-cage general-purpose motors as follows:	
Single speed; Polyphase; 1–200 hp with 3-digit frame sizes; 2, 4, & 6 pole (3600, 1800, & 1200 rpm); NEMA design A & B (including IEC equivalent); Continuous rated	
Not Included in Premium Efficiency standards, but must now meet EPAct standards:	
JM; JP; Round body (footless); 201–500 hp; Fire pump; U-frame; Design C; 8-pole	
<i>Certain motors (Inverter/Vector Duty, NEMA design D, etc.) are not covered by EISA 2007. For full text, visit www.energy.senate.gov and click "ENERGY INDEPENDENCE & SECURITY ACT OF 2007".</i>	

Nominal Full-Load Efficiency Standards Comparisons (%)						
Enclosed Electric Motors, Random Wound, 60 Hz, 600V or Less						
Motor HP	1200 rpm [6-pole]		1800 rpm [4-pole]		3600 rpm [2-pole]	
	EPAct	Premium Efficiency	EPAct	Premium Efficiency	EPAct	Premium Efficiency
1	80.0	82.5	82.5	85.5	75.5	77.0
1.5	85.5	87.5	84.0	86.5	82.5	84.0
2	86.5	88.5	84.0	86.5	84.0	85.5
3	87.5	89.5	87.5	89.5	85.5	86.5
5	87.5	89.5	87.5	89.5	87.5	88.5
7.5	89.5	91.0	89.5	91.7	88.5	89.5
10	89.5	91.0	89.5	91.7	89.5	90.2
15	90.2	91.7	91.0	92.4	90.2	91.0
20	90.2	91.7	91.0	93.0	90.2	91.0
25	91.7	93.0	92.4	93.6	91.0	91.7
30	91.7	93.0	92.4	93.6	91.0	91.7
40	93.0	94.1	93.0	94.1	91.7	92.4
50	93.0	94.1	93.0	94.5	92.4	93.0
60	93.6	94.5	93.6	95.0	93.0	93.6
75	93.6	94.5	94.1	95.4	93.0	93.6
100	94.1	95.0	94.5	95.4	93.6	94.1
125	94.1	95.0	94.5	95.4	94.5	95.0
150	95.0	95.8	95.0	95.8	94.5	95.0
200	95.0	95.8	95.0	96.2	95.0	95.4

NEMA Premium® Efficiency XRI® Series Inverter Duty Motors



Features

- Meets or exceeds NEMA Premium efficiencies
- Inverter duty
- 10:1 variable torque and constant torque on VFD with 1.0 service factor
- 1.15 service factor on sinewave; 1.0 service factor on IGBT power
- Class F insulation
- Continuous duty at 40° C ambient
- Rolled steel construction with C-face rigid base mounting
- F3 conduit box location
- Utilizes ball bearings
- Electrically reversible
- UL recognized and CSA certified
- Three year warranty (through Marathon Electric)

Applications

Typical uses include gear reducers, pumps, machine tools, and other direct-coupled equipment installed in damp, dusty, or dirty environments where long life and ultra-high efficiency is desired.

Motor Shipping Schedule

Same or one day *

* For same-day shipping of stock motors requiring LTL shipment, order before 5 p.m. EST.

208-230/460V Motor Specifications

Part Number	Price	HP	Base RPM	Volts	Enclosure	NEMA Frame	Model No.	N.P. F.L. Amps	Weight (lb)
E2000	<--->	1	3600	208-230/460	TEFC	56C	056T34F5940	3.0-2.8/1.4	28
E2001	<--->	1	1800			143TC	143TTFR5642	3.2-3.2/1.6	32
E2002	<--->	1	1200			145TC	145TTFR6078	3.8-3.8/1.9	42
E2003	<--->	1.5	3600			143TC	143TTFR5582	4.4-4.0/2.0	39
E2004	<--->	1.5	1800			145TC	145TTFR6033	5.2-4.8/2.4	34
E2005 †	<--->	1.5	1200			182TC	182TTFW6076	5.6-5.2/2.6	77
E2006	<--->	2	3600			145TC	145TTFR3002	5.2-4.8/2.4	48
E2007	<--->	2	1800			145TC	145TTFR6035	6-5.8/2.9	50
E2008 †	<--->	2	1200			184TC	184TTFW6076AA	7.35-6.4/3.2	94
E2009 †	<--->	3	3600			182TC	182TTFW6001AA	8.4-7.8/3.9	63
E2010 †	<--->	3	1800			182TC	182TTFW6026AA	8.4-7.8/3.9	87
E2011*	<--->	3	1200			213TC	213TTFW6076	9.2-8.8/4.4	125
E2012 †	<--->	5	3600			184TC	184TTFW6001AA	13-12/6	86
E2013 †	<--->	5	1800			184TC	184TTFW6026AA	13.8-12.6/6.3	87
E2014*	<--->	5	1200			215TC	215TTFW6076	15.0-14.0/7.0	160
E2015*	<--->	7.5	3600			213TC	213TTFW6001	19.6-17.8/8.9	116
E2016*	<--->	7.5	1800			213TC	213TTFW6026	21.0-19.4/9.7	143
E2018*	<--->	10	3600			215TC	215TTFW6001	26.4-23.6/11.8	230
E2019*	<--->	10	1800			215TC	215TTFW6026	28.0-25.6/12.8	164

† These specifications are for the Marathon motor currently being sold. Marathon manufactured a previous version of this Part Number (that had a different model #), and that version had some different specifications. For detailed information on the previous motor, please refer to the "Previous Marathon Model Numbers" table on the next page, or click on the previous motor's specification at www.AutomationDirect.com/Retired-Products.

Note: Please review the AutomationDirect Terms & Conditions for warranty and service on this product. Warranty service can be arranged through numerous Marathon Electric service centers. See list of service centers on our Web site at www.automationdirect.com.

NEMA Premium® Efficiency XRI® Series Inverter Duty Motors

Motor Performance Data

Performance Data (460 Volt)															
Part Number	HP	NEMA Design	F.L. RPM	Min RPM	Current (Amps)			Torque (lb-ft)			Max CHP RPM*	Max Safe RPM	F.L. Effic. (%)	F.L. Power Factor	Rotor Inertia (lb-ft ²)
					No Load	Full Load	Locked Rotor	Full Load	Locked Rotor	Break-down					
E2000	1	B	3490	349	0.7	1.4	10	1.5	3.6	5.1	5235	7200	80	84	0.04
E2001	1		1760	176	1.0	1.6	14	3.0	12.0	15.8	2640	5400	85.5	68.5	0.12
E2002	1		1170	117	1.3	1.9	10	4.5	13.5	15.8	1755	5400	82.5	60	0.14
E2003	1.5		3490	349	1.0	2.0	21	2.3	8.5	11.2	5235	7200	84.0	82	0.06
E2004	1.5		1750	175	1.2	2.4	18	4.5	14.8	19.8	2625	5400	86.5	67.7	0.14
E2005 †	1.5		1175	118	1.3	2.6	17	6.8	13.4	24.4	1762.5	5400	87.5	71.5	0.38
E2006	2		3490	349	1.0	2.4	26	3.0	10.8	13.0	5235	7200	85.5	88	0.08
E2007	2		1745	175	1.7	2.9	27	6.0	24.6	28.8	2617.5	5400	86.5	75.6	0.16
E2008 †	2		1170	117	1.9	3.2	20.5	9	16.8	30.2	1755	4000	88.5	67	0.162
E2009 †	3		3510	351	1.8	3.9	33	4.5	11	18.2	5265	7200	86.5	83	0.23
E2010 †	3		1760	176	1.9	3.9	33.5	8.9	22.5	36.0	2640	4000	89.5	80.5	0.383
E2011	3		1170	117	2.5	4.4	32	13.5	34.0	47.5	1755	4200	89.5	70	0.80
E2012 †	5		3495	350	1.7	6	46	7.5	16	26	5243	5400	88.5	89.5	0.3
E2013 †	5		1760	176	2.4	6.3	49	14.96	30.1	50.2	2640	4000	89.5	83	0.485
E2014	5		1170	117	3.7	7.0	46	22.5	47.0	79	1755	4200	90.2	75	1.0
E2015	7.5		3540	354	3.0	8.9	64	11.1	24.0	38.0	5310	5400	90.2	87	0.55
E2016	7.5		1765	177	4.7	9.7	64	22.0	52	72	2647.5	4200	91.7	80	0.85
E2018	10		3535	354	3.5	11.8	80	14.9	30.0	46.0	5302.5	5400	91.7	87	0.65
E2019	10		1760	176	5.5	12.8	80	29.8	65	90	2640	4200	91.7	80	1.1

* Maximum Constant HP RPM is for direct coupled loads.

† These specifications are for the Marathon motor currently being sold. Marathon manufactured a previous version of this Part Number (that had a different model #), and that version had some different specifications. For detailed information on the previous motor, please refer to the "Previous Marathon Model Numbers" table below, or click on the previous motor's specification at www.AutomationDirect.com/Retired-Products.

Previous Marathon Model Numbers				
Part Number	HP	Current Model #	Previous Model #	Date of Change-over
E2005	1.5	182TTFW6076	182TTFR6076	09/2011
E2008	2	184TTFW6076AA	184TTFR6076	09/2011
E2009	3	182TTFW6001AA	182TTFR6001	09/2011
E2010	3	182TTFW6026AA	182TTFW6026	09/2011
E2012	5	184TTFW6001AA	184TTFW6001	09/2011
E2013	5	184TTFW6026AA	184TTFW6026	09/2011

Visit www.AutomationDirect.com/Retired-Products for detailed specifications of previous models. (The model # appears on the motor nameplate.)

NEMA Premium® Efficiency XRI® Series Inverter Duty Motors

Motor Dimensions (units = inches)

Frame 56C – Part #: E2000

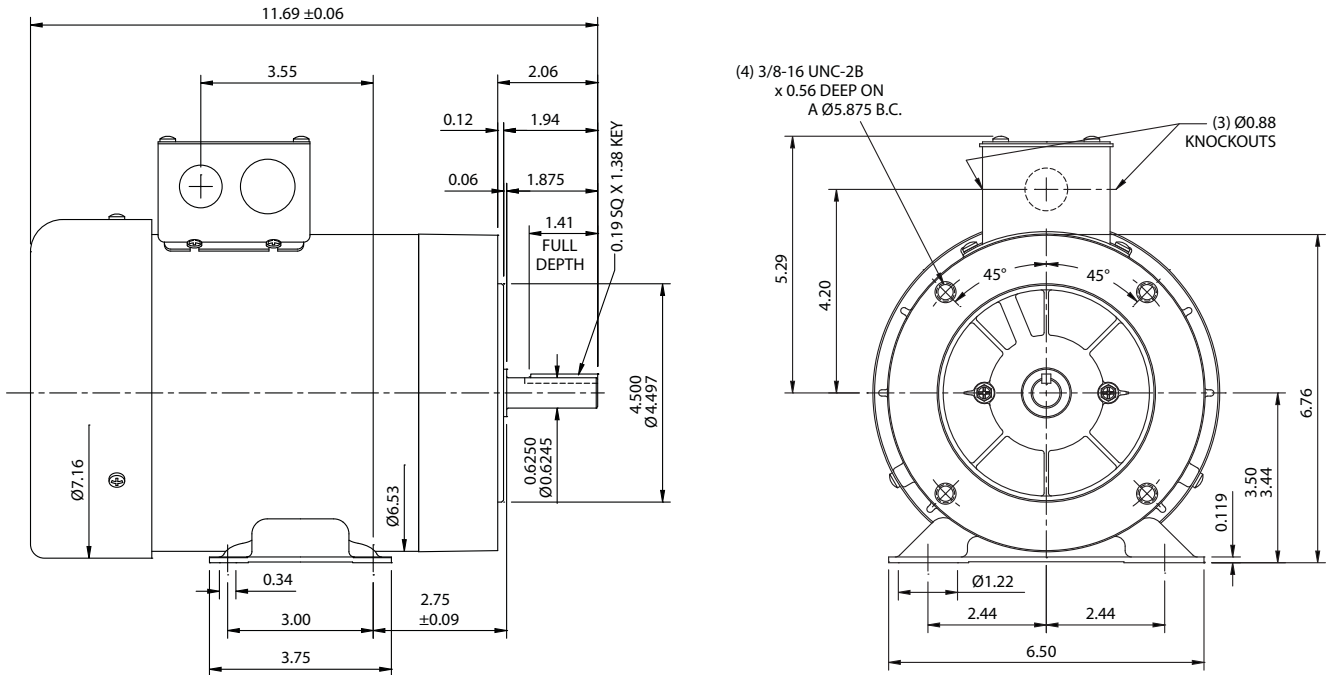

Frame 143/5TC – Part #: E2001, E2002, E2003, E2004, E2006, E2007

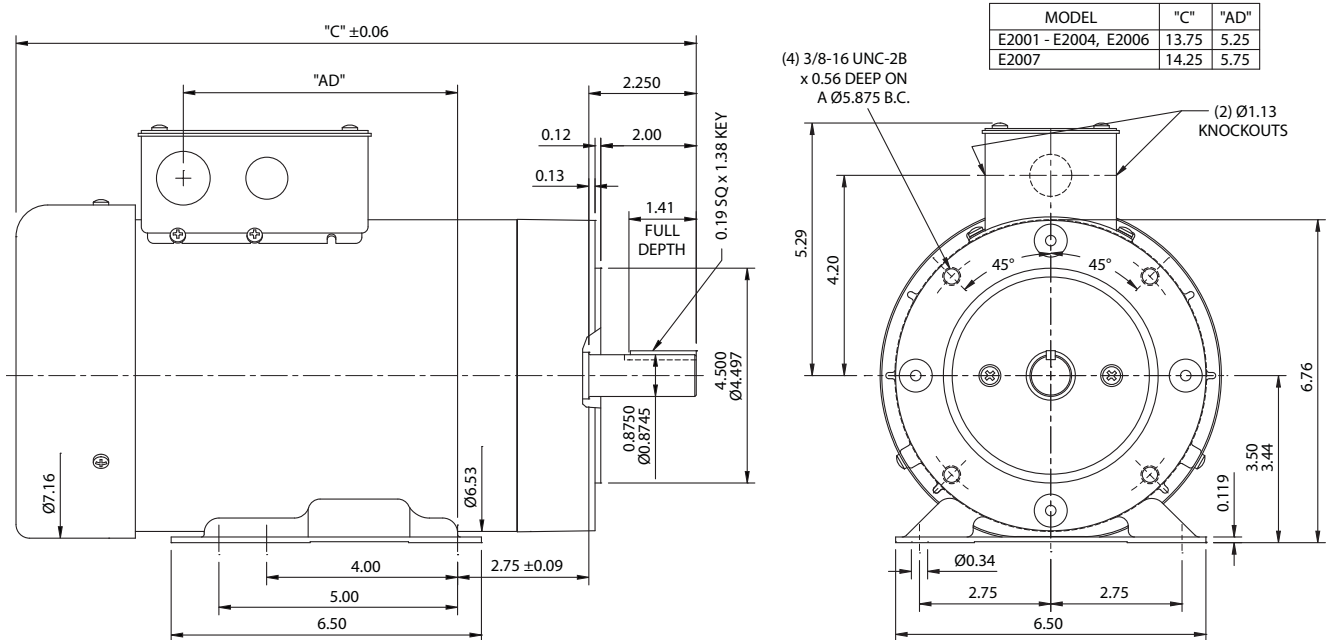

NEMA Premium® Efficiency XRI® Series Inverter Duty Motors

Motor Dimensions (units = inches)

Frame 182TC – Part #: E2005

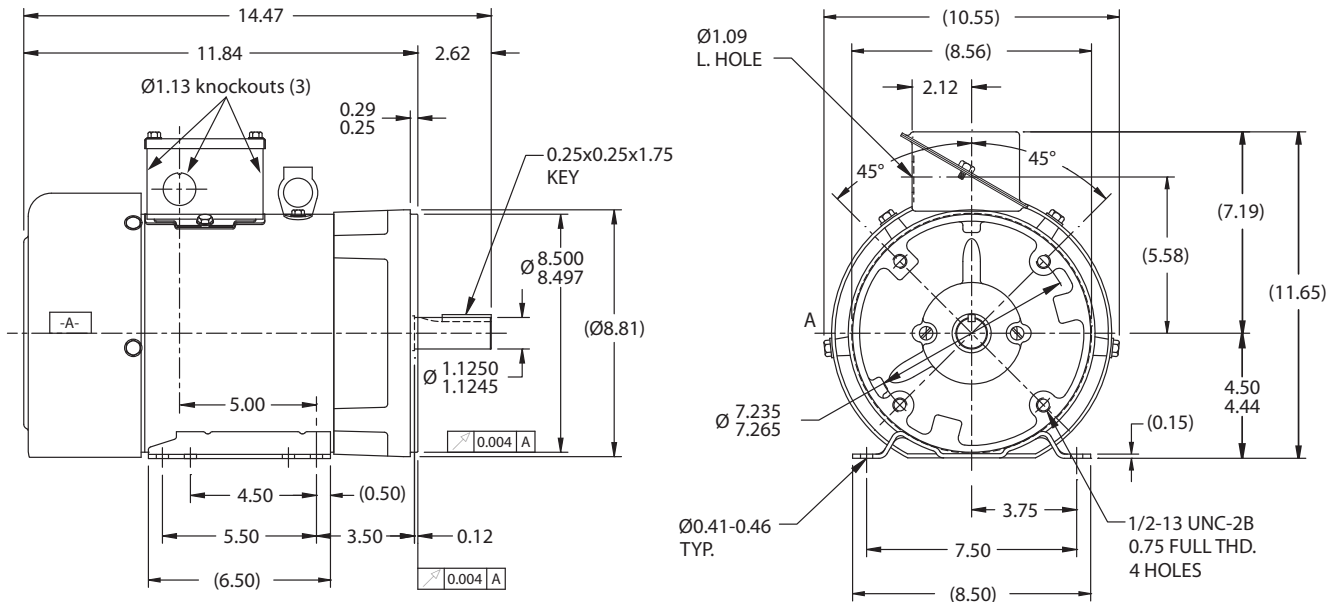

MODEL # E2005 (182TTFW6076)

- NOTES:
1. BOX CAN BE ROTATED IN 90° STEPS.
2. NAMEPLATE READ FROM LOCATION 'A'.

Frame 182/4TC – Part #: E2008, E2009, E2010, E2013

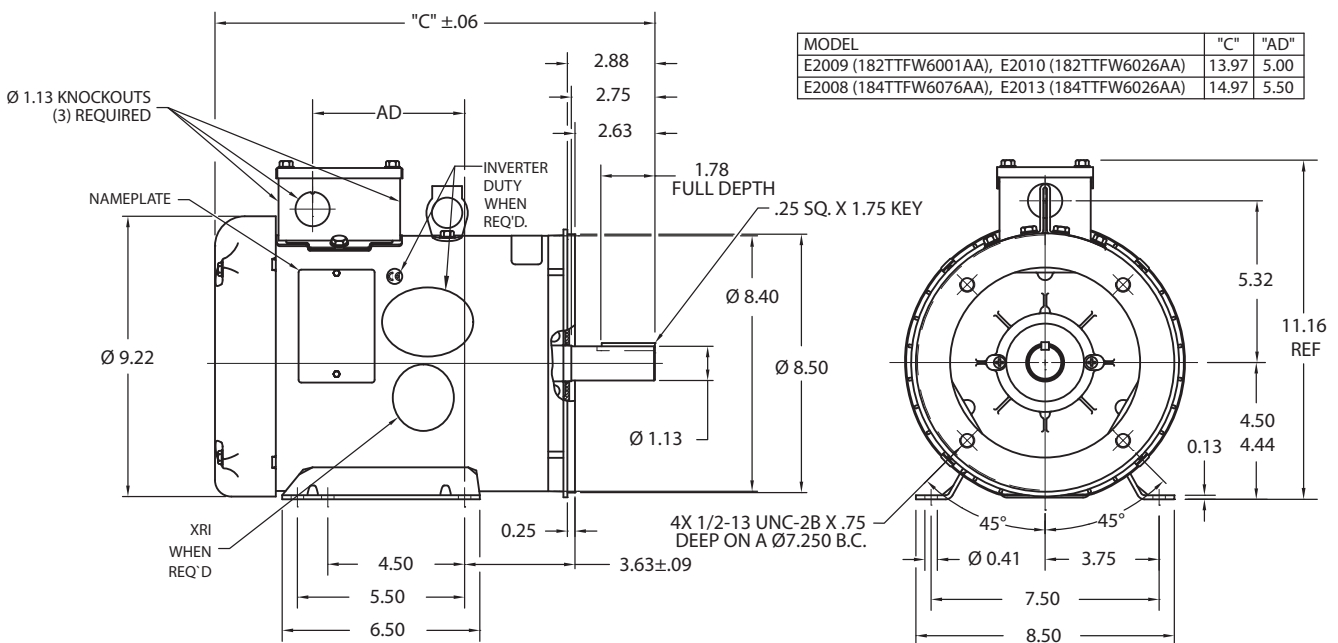

STABLE™ Motor Slide Bases

Mounting Slide Bases for 56 to 449T NEMA Motors

Features

- Allows adjustment of motor mounting position
- Double adjusting screws for frames 182T - 449T
- Manufactured to precise dimensional standards
- Dimensionally interchangeable with existing major makes
- Heavy-duty steel construction
- Painted with oven-baked primer for better adhesion of customer's paint
- All "D" bolts (motor mounting bolts) are fixed to the exact motor foot pattern
- All "D" bolts are welded into position to prevent spinning and dropping from slots
- Bases are provided with washers



Motor Slide Bases											
Part Number	Price	Fits Frame Type	Product Weight (lb)	Fits Motor							
				IronHorse	Marathon micro -MAX	Marathon Black Max 230/460V	Marathon Black Max 575V	Marathon Blue Max	Marathon NEMA Premium XRI	Marathon Blue Chip XRI 230/460V	Marathon Blue Chip XRI 575V
MTA-BASE-W56	<-->	56	2.8	MTR-xxx-xxxx MTPM-xxx-xxxx	Y500 Y360 Y364	Y592(-A772) Y534(-A772) Y535(-A772)	Y555(-A772) Y556(-A772)	-	E2000	-	-
MTA-BASE-W143T	<-->	143T/TC	4.6	MTCP-001-3BD18(C) MTCP-1P5-3BD36	-	Y536(-A772)	-	-	E2001 E2003	-	-
MTA-BASE-W145T	<-->	145T/TC	5.1	MTCP-001-3BD12 MTCP-1P5-3BD18(C) MTCP-002-3BD18(C) MTCP-002-3BD36	Y368	Y537(-A772) Y538(-A772) Y551(-A772)	Y557(-A772)	-	E2002 E2004 E2006 E2007	-	-
MTA-BASE-W182T	<-->	182T/TC	9.2	MTCP-1P5-3BD12 MTCP-003-3BD18(C) MTCP-003-3BD36	Y1999	Y541(-A772)	Y558(-A772)	-	E2005 E2009 E2010	-	-
MTA-BASE-W184T	<-->	184T/TC	10	MTCP-002-3BD12 MTCP-005-3BD18(C) MTCP-005-3BD36	Y1372	Y540(-A772) Y543(-A772)	Y559(-A772)	-	E2008 E2012 E2013	-	-
MTA-BASE-W213T	<-->	213T/TC	13	MTCP-003-3BD12 MTCP-7P5-3BD18(C) MTCP-7P5-3BD36	Y994	Y542(-A772) Y545(-A772)	Y560(-A772)	-	E2011 E2015 E2016	-	-
MTA-BASE-W215T	<-->	215T/TC	15	MTCP-005-3BD12 MTCP-010-3BD18(C) MTCP-010-3BD36	Y996	Y544(-A772) Y547(-A772)	Y561(-A772)	-	E2014 E2018 E2019	-	-
MTA-BASE-W254T	<-->	254T/TC	18	MTCP-7P5-3BD12 MTCP-015-3BD18(C) MTCP-015-3BD36	-	Y546(-A772) Y549(-A772)	Y562(-A772)	-	-	E205	E307
MTA-BASE-W256T	<-->	256T/TC	19	MTCP-010-3BD12 MTCP-020-3BD18(C) MTCP-020-3BD36	-	Y548(-A772) Y552(-A772)	Y563(-A772)	-	-	E206	E308
MTA-BASE-W284T	<-->	284T/TC	20	MTCP-015-3BD12 MTCP-025-3BD18(C)	-	Y553(-A772)	-	-	-	E207	E309
MTA-BASE-W286T	<-->	286T/TC	21	MTCP-020-3BD12 MTCP-030-3BD18(C)	-	Y393(-A772)	-	-	-	E208	E310
MTA-BASE-W324T	<-->	324T/TC	30	MTCP-040-3BD18(C)	-	-	-	Y571(-A774) Y513(-A775)	-	E209	E311
MTA-BASE-W326T	<-->	326T/TC	31	MTCP-050-3BD18(C)	-	-	-	Y572(-A774) Y514(-A775)	-	E210	E312
MTA-BASE-W364T	<-->	364T/TC	43	MTCP-060-3BD18(C)	-	-	-	Y573(-A774) Y515(-A775)	-	E211	E313
MTA-BASE-W365T	<-->	365T/TC	43	MTCP-075-3BD18(C)	-	-	-	Y574(-A774) Y516(-A775)	-	E212	E315
MTA-BASE-W404T	<-->	404T/TC	58	-	-	-	-	-	-	-	-
MTA-BASE-W405T	<-->	405T/TC	60	MTCP-100-3BD18(C)	-	-	-	Y575(-A774) Y517(-A775)	-	E213	E314
MTA-BASE-W444T	<-->	444T	63	MTCP-125-3BD18	-	-	-	-	-	-	-
MTA-BASE-W445T	<-->	445T	65	MTCP-150-3BD18	-	-	-	-	-	-	-
MTA-BASE-W447T	<-->	445/7T 447T	89	MTCP-200-3BD18	-	-	-	-	-	-	-
MTA-BASE-W449T	<-->	449T	94	MTC-250-3D18 MTC-300-3D18	-	-	-	-	-	-	-

STABLE Motor Slide Bases

Dimensions – Mounting Slide Bases for NEMA Motors

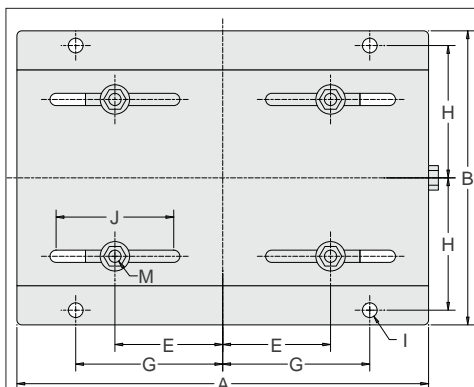

W56 - W145T Motor Slide Base Dimensions

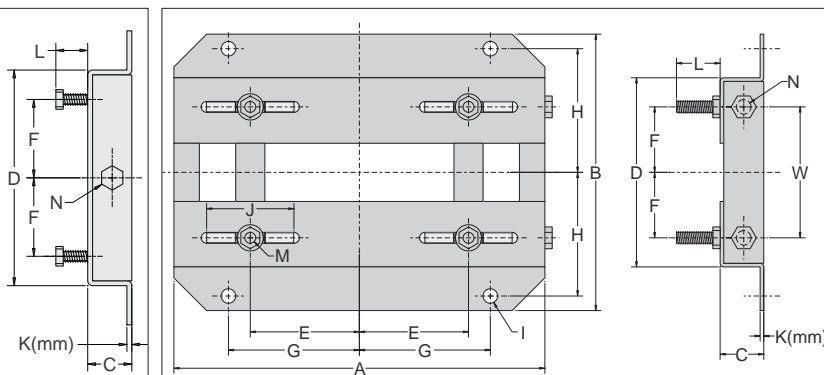
 W182T - W449T Motor Slide Base Dimensions
 (W182T-W215T bases have one-piece top plates, similar to W56-W145T)

Dimensions [inches, except as noted] - STABLE Motor Slide Bases

MTA-BASE-Wxxxx	A	B	C	D	E	F	G	H	I	J	K(mm)	L	M	N	W
56	10-5/8	6-1/2	1-1/8	4-1/2	2-7/16	1-1/2	3-13/16	2-7/8	3/8	3	2 mm	7/8	5/16 x 1	3/8 x 4	n/a
143T	10-1/2	7-1/2	1-1/8	5-1/2	2-3/4	2	3-3/4	3-3/8	3/8	3	3 mm	13/16	5/16 x 1	3/8 x 4	n/a
145T	10-1/2	8-1/2	1-1/8	6-1/2	2-3/4	2-1/2	3-3/4	3-7/8	3/8	3	3 mm	13/16	5/16 x 1	3/8 x 4	n/a
182T	12-3/4	9-1/2	1-1/2	6-1/2	3-3/4	2-1/4	4-1/2	4-1/4	1/2	3	3.5 mm	1-1/2	3/8 x 1-3/4	1/2 x 6	4-1/2
184T	12-3/4	10-1/2	1-1/2	7-1/2	3-3/4	2-3/4	4-1/2	4-3/4	1/2	3	3.5 mm	1-1/2	3/8 x 1-3/4	1/2 x 6	5-1/2
213T	15	11	1-3/4	7-1/2	4-1/4	2-3/4	5-1/4	4-3/4	1/2	3-1/2	3.8 mm	1-1/2	3/8 x 1-3/4	1/2 x 6	5-1/2
215T	15	12-1/2	1-3/4	9	4-1/4	3-1/2	5-1/4	5-1/2	1/2	3-1/2	3.8 mm	1-1/2	3/8 x 1-3/4	1/2 x 6	7
254T	17-3/4	15-1/8	2	10-3/4	5	4-1/8	6-1/4	6-5/8	5/8	4	4.6 mm	1-7/16	1/2 x 1-3/4	5/8 x 6	5-5/16
256T	17-3/4	16-7/8	2	12-1/2	5	5	6-1/4	7-1/2	5/8	4	4.6 mm	1-7/16	1/2 x 1-3/4	5/8 x 6	7
284T	19-3/4	16-7/8	2	12-1/2	5-1/2	4-3/4	7	7-1/2	5/8	4-1/2	4.6 mm	1-11/16	1/2 x 2	5/8 x 6	7
286T	19-3/4	18-3/8	2	14	5-1/2	5-1/2	7	8-1/4	5/8	4-1/2	4.6 mm	1-11/16	1/2 x 2	5/8 x 6	8
324T	22-3/4	19-1/4	2-1/2	14	6-1/4	5-1/4	8	8-1/2	3/4	5-1/4	4.6 mm	2-3/16	5/8 x 2-1/2	3/4 x 9	7
326T	22-3/4	20-3/4	2-1/2	15-1/2	6-1/4	6	8	9-1/4	3/4	5-1/4	4.6 mm	2-3/16	5/8 x 2-1/2	3/4 x 9	8-1/2
364T	25-1/2	20-1/2	2-1/2	15-1/2	7	5-5/8	9	9-1/8	3/4	6	5.8 mm	2-1/16	5/8 x 2-1/2	3/4 x 9	7-3/4
365T	25-1/2	21-1/2	2-1/2	16-1/2	7	6-1/8	9	9-5/8	3/4	6	5.8 mm	2-1/16	5/8 x 2-1/2	3/4 x 9	8-3/4
404T	28-3/4	22-3/8	3	16-1/2	8	6-1/8	10	9-7/8	7/8	7	5.8 mm	2-1/2	3/4 x 3	3/4 x 11	8-3/4
405T	28-3/4	23-7/8	3	18	8	6-7/8	10	10-5/8	7/8	7	5.8 mm	2-1/2	3/4 x 3	3/4 x 11	10-1/4
444T	31-1/4	24-5/8	3	19-1/4	9	7-1/4	11	11	7/8	7-1/2	5.8 mm	2-1/2	3/4 x 3	3/4 x 11	11
445T	31-1/4	26-5/8	3	21-1/4	9	8-1/4	11	12	7/8	7-1/2	5.8 mm	2-1/2	3/4 x 3	3/4 x 11	13
447T	31-1/4	30-1/8	3	24-3/4	9	10	11	13-3/4	7/8	7-1/2	8 mm	3	3/4 x 3-1/2	3/4 x 11	16-1/2
449T	31-1/4	35-1/8	3	29-3/4	9	12-1/2	11	16-1/4	7/8	7-1/2	8 mm	3	3/4 x 3-1/2	3/4 x 11	21-1/2