

WC10 NEMA 12 Operator Consoles



Applications

Designed to hold electrical and electronic controls and instruments. Heavy duty construction provides protection from dirt, dust, oil and water. Pushbuttons, pilot lights, meters, switches, etc. can be mounted on sloping control surfaces. Interior components can be mounted on subpanel and terminal straps.



Construction

Body

- Fabricated from 14 gauge steel
- Seams are continuously welded and ground smooth
- 3-point keylocking handle is provided on front, main door
- Flush main door
- Control panels are hinged along bottom edge
- Control panels have captivated screws threaded into sealed wells
- Door stops provided to hold control panel open
- Print pocket is provided
- Standard closed cell neoprene gasket
- Removable subpanel is included with enclosure
- Grounding provisions provided

Top

- Fabricated from 14 gauge steel
- Seams are continuously welded and ground smooth
- Instrument and access panels have captivated screws that thread into sealed wells
- Closed cell neoprene gasket

Writing desk

- Fabricated from 14-gauge steel
- Seams are continuously welded and ground smooth
- Desks are removable and attach easily to console front

Finish

- ANSI-61 gray polyester powder inside and out over phosphatized surfaces
- Included subpanel is white polyester powder over phosphatized surfaces

Listings

- UL 508, Types 12 and 13
- UL File E64791
- CSA Certified, Type 12 & 13
- CSA File LL66078
- NEMA/EEMAC Types 12 & 13

Enclosure Shipping Schedule		
Same day	1 - 7 days	1 -10 days
Color indicates shipping lead time in business days.		

Part Number	Price	Body/Door	Description
WC10B*	<--->	14 /14	Console body only, 24" (610) wide
WC10T	<--->	14 /14	Top for WC10B
WC10W	<--->	14 /14	Writing desk for WC10B
WC10C	<--->	14 /14	Caster kit: Set of 4 castors, 2 mounting plate and hardware

Note: Dimensions in inches (millimeters); letters in table correspond to letters on dimensional drawings. * UL Listed. Subpanels are included with console. Note: Tops, writing desks and caster kits must be ordered separately.

WC10 NEMA 12 Operator Consoles

Dimensions

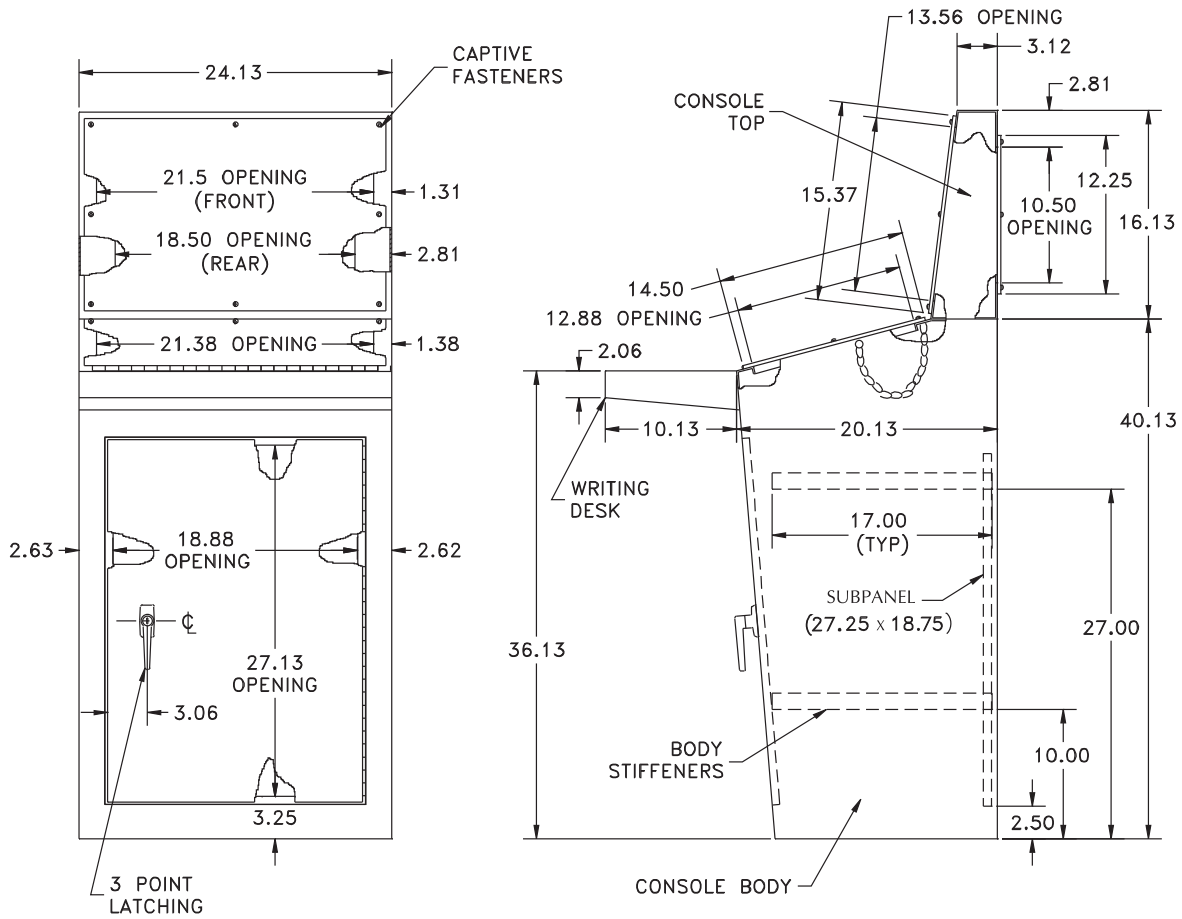

Notes:

1. Access doors open 180 degrees.
2. One 8"x10" Print Pocket is provided.
3. 3-point key-locking handles are provided on main doors.
4. Writing desk is provided with mounting hardware.
5. 27.25 x 18.75 subpanel included.

PLC Overview

DL05/06 PLC

DL105 PLC

DL205 PLC

DL305 PLC

DL405 PLC

Field I/O

Software

C-more HMIs

Other HMI

AC Drives

Motors

Steppers/Servos

Motor Controls

Proximity Sensors

Photo Sensors

Limit Switches

Encoders

Current Sensors

Pushbuttons/Lights

Process

Relays/Timers

Comm.

TB's & Wiring

Power

Circuit Protection

Enclosures

Appendix

Part Index