

D-Series Heavy Duty Pneumatic Cylinder Accessories					
Part Number	Description	Pcs/Pkg	Wt (lb)	Price	
DRC-2	Cylinder rod clevis, 7/16-20 thread, for use with 1-1/2, 2 and 2-1/2 inch bore NITRA NFPA D-series pneumatic cylinders	1	0.6	<--->	
DRC-4	Cylinder rod clevis, 3/4-16 thread, for use with 3-1/4 and 4 inch bore NITRA NFPA D-series pneumatic cylinders	1	1.6	<--->	
DRE-1	Cylinder rod eye, 7/16-20 thread, for use with 1-1/2, 2 and 2-1/2 inch bore NITRA NFPA D-series pneumatic cylinders	1	0.4	<--->	
DRE-2	Cylinder rod eye, 3/4-16 thread, for use with 3-1/4 and 4 inch bore NITRA NFPA D-series pneumatic cylinders	1	1.2	<--->	
DPC-1	NFPA style MP2 cylinder rear clevis bracket and attaching hardware, for use with 1-1/2 inch bore NITRA NFPA D-series pneumatic cylinders	1	0.5	<--->	
DPC-2	NFPA style MP2 cylinder rear clevis bracket and attaching hardware, for use with 2 inch bore NITRA NFPA D-series pneumatic cylinders	1	0.7	<--->	
DPC-3	NFPA style MP2 cylinder rear clevis bracket and attaching hardware, for use with 2-1/2 inch bore NITRA NFPA D-series pneumatic cylinders	1	0.8	<--->	
DPC-4	NFPA style MP2 cylinder rear clevis bracket and attaching hardware, for use with 3-1/4 inch bore NITRA NFPA D-series pneumatic cylinders	1	1.6	<--->	
DPC-5	NFPA style MP2 cylinder rear clevis bracket and attaching hardware, for use with 4 inch bore NITRA NFPA D-series pneumatic cylinders	1	1.7	<--->	
DPA-1	NFPA style MP4 cylinder rear pivot eye and attaching hardware, for use with 1-1/2 inch bore NITRA NFPA D-series pneumatic cylinders	1	0.4	<--->	
DPA-2	NFPA style MP4 cylinder rear pivot eye and attaching hardware, for use with 2 inch bore NITRA NFPA D-series pneumatic cylinders	1	0.5	<--->	
DPA-3	NFPA style MP4 cylinder rear pivot eye and attaching hardware, for use with 2-1/2 inch bore NITRA NFPA D-series pneumatic cylinders	1	0.7	<--->	
DPA-4	NFPA style MP4 cylinder rear pivot eye and attaching hardware, for use with 3-1/4 inch bore NITRA NFPA D-series pneumatic cylinders	1	1.3	<--->	
DPA-5	NFPA style MP4 cylinder rear pivot eye and attaching hardware, for use with 4 inch bore NITRA NFPA D-series pneumatic cylinders	1	1.4	<--->	
DFM-1	NFPA style MF1 or MF2 cylinder flange mounting plate and attaching hardware, for use with 1-1/2 inch bore NITRA NFPA D-series pneumatic cylinders	1	0.3	<--->	
DFM-2	NFPA style MF1 or MF2 cylinder flange mounting plate and attaching hardware, for use with 2 inch bore NITRA NFPA D-series pneumatic cylinders	1	0.4	<--->	
DFM-3	NFPA style MF1 or MF2 cylinder flange mounting plate and attaching hardware, for use with 2-1/2 inch bore NITRA NFPA D-series pneumatic cylinders	1	0.5	<--->	
DFM-4	NFPA style MF1 or MF2 cylinder flange mounting plate and attaching hardware, for use with 3-1/4 inch bore NITRA NFPA D-series pneumatic cylinders	1	3.0	<--->	
DFM-5	NFPA style MF1 or MF2 cylinder flange mounting plate and attaching hardware, for use with 4 inch bore NITRA NFPA D-series pneumatic cylinders	1	4.3	<--->	

Rod Clevis

Dimensions: in [mm]

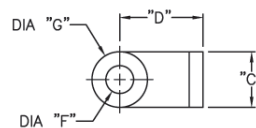
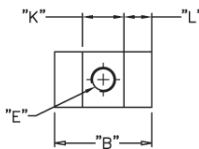
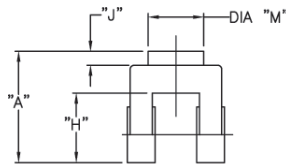

Note: Comes with Pivot Pin installed.

Rod Clevis Dimension Table

Part #	A	B	C	D	E	(Dia) F	(Dia) G	H	J	K	L	M
DRC-2	2.00 [50.8]	1.75 [44.5]	1.00 [25.4]	1.50 [38.1]	7/16-20	ø0.50 [ø12.7]	ø1.00 [ø25.4]	1.25 [31.8]	0.25 [6.4]	0.75 [19.1]	0.50 [12.7]	ø1.00 [ø25.4]
DRC-4	3.13 [79.5]	2.50 [63.5]	1.50 [38.1]	2.38 [60.5]	3/4-16	ø0.75 [ø19.1]	ø1.50 [ø38.1]	2.00 [50.8]	0.31 [7.8]	1.25 [31.8]	0.63 [16.0]	ø1.50 [ø38.1]

Rod Eye

Dimensions: in [mm]

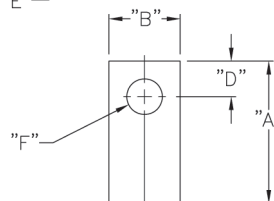
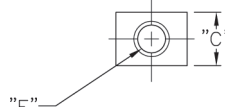

Rod Eye Dimension Table

Part #	A	B	C	D	E	(Dia) F
DRE-1	2.00 [50.8]	1.00 [25.4]	0.75 [19.1]	0.50 [12.7]	7/16-20 x 3/4	ø0.50 [ø12.7]
DRE-2	2.81 [71.4]	1.50 [38.1]	1.25 [31.8]	0.75 [19.1]	3/4-16 x 1-1/18	ø0.75 [ø19.1]

Rear Clevis

Dimensions: in [mm]

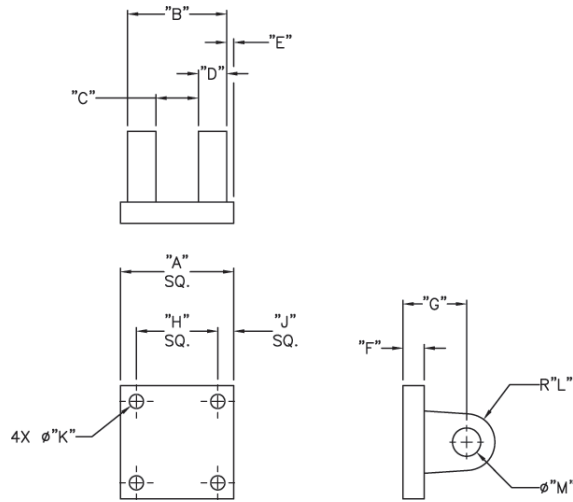

Note: Comes with Pivot Pin installed.

Rear Clevis Dimension Table

Part #	A	B	C	D	E	F	G	H	J	(Dia) K	(R) L	(Dia) M
DPC-1	2.00 [50.8]	1.75 [44.5]	0.75 [19.1]	0.50 [12.7]	0.13 [3.3]	0.38 [9.7]	1.13 [28.7]	1.44 [36.6]	0.28 [7.1]	ø0.27 [ø6.9]	R 0.50 [R 12.7]	ø0.50 [ø12.7]
DPC-2	2.50 [63.5]	1.75 [44.5]	0.75 [19.1]	0.50 [12.7]	0.38 [9.7]	0.38 [9.7]	1.13 [28.7]	1.84 [46.7]	0.33 [8.4]	ø0.36 [ø9.1]	R 0.50 [R 12.7]	ø0.50 [ø12.7]
DPC-3	3.00 [76.2]	1.75 [44.5]	0.75 [19.1]	0.50 [12.7]	0.63 [16.0]	0.38 [9.7]	1.13 [28.7]	2.19 [55.6]	0.41 [10.4]	ø0.36 [ø9.1]	R 0.50 [R 12.7]	ø0.50 [ø12.7]
DPC-4	3.75 [95.3]	2.63 [66.8]	1.25 [31.8]	0.63 [16.0]	0.63 [16.0]	0.63 [16.0]	1.88 [47.8]	2.75 [69.9]	0.50 [12.7]	ø0.44 [ø11.2]	R 0.75 [R 19.1]	ø0.75 [ø19.1]
DPC-5	4.50 [114.3]	2.63 [66.8]	1.25 [31.8]	0.63 [16.0]	1.00 [25.4]	0.63 [16.0]	1.88 [47.8]	3.33 [84.6]	0.59 [15.0]	ø0.44 [ø11.2]	R 0.75 [R 19.1]	ø0.75 [ø19.1]

Rear Pivot Eye

Dimensions: in [mm]

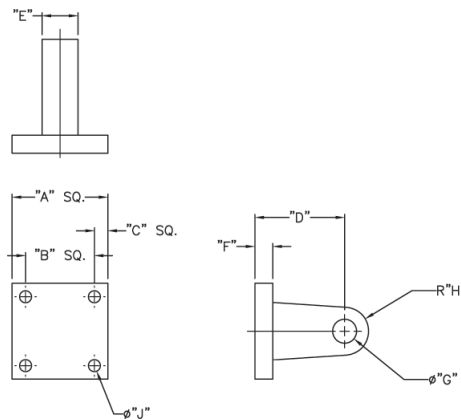

Rear Pivot Eye Dimension Table

Part #	A	B	C	D	E	F	(Dia) G	(R) H	(Dia) J
DPA-1	2.00 [50.8]	1.44 [36.6]	0.28 [7.1]	1.13 [28.7]	0.75 [19.1]	0.38 [9.70]	ø0.50 [ø12.7]	R 0.50 [R 12.7]	ø0.27 [ø6.9]
DPA-2	2.50 [63.5]	1.84 [46.7]	0.33 [8.4]	1.13 [28.7]	0.75 [19.1]	0.38 [9.70]	ø0.50 [ø12.7]	R 0.50 [R 12.7]	ø0.36 [ø9.1]
DPA-3	3.00 [76.2]	2.19 [55.6]	0.41 [10.4]	1.13 [28.7]	0.75 [19.1]	0.38 [9.70]	ø0.50 [ø12.7]	R 0.50 [R 12.7]	ø0.36 [ø9.1]
DPA-4	3.75 [95.3]	2.75 [69.9]	0.50 [12.7]	1.88 [47.8]	1.25 [31.8]	0.63 [16.0]	ø0.75 [ø19.1]	R 0.75 [R 19.1]	ø0.44 [ø11.2]
DPA-5	4.50 [114.3]	3.33 [84.6]	0.59 [15.0]	1.88 [47.8]	1.25 [31.8]	0.63 [16.0]	ø0.75 [ø19.1]	R 0.75 [R 19.1]	ø0.44 [ø11.2]

Flange Attachment

Dimensions: in [mm]

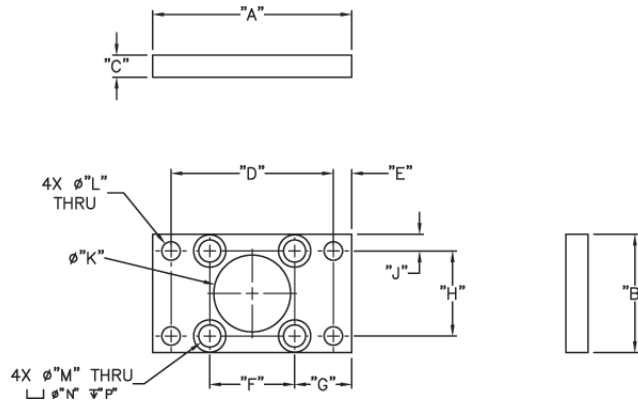

Flange Attachment Dimension Table

Part #	A	B	C	D	E	F	G	H	J	(Dia) K	(Dia) L	(Dia) M	(Dia) N	P
DFM-1	3.38 [85.9]	2.00 [50.8]	0.38 [9.7]	2.75 [69.9]	0.31 [7.9]	1.44 [36.6]	0.97 [24.6]	1.44 [36.6]	0.28 [7.1]	ø1.30 [ø33.0]	ø0.31 [ø7.9]	ø0.38 [ø9.7]	ø0.66 [ø16.8]	0.16 [4.1]
DFM-2	4.13 [104.9]	2.50 [63.5]	0.38 [9.7]	3.38 [85.9]	0.38 [9.7]	1.84 [46.7]	1.14 [29.0]	1.84 [46.7]	0.33 [8.4]	ø1.30 [ø33.0]	ø0.38 [ø9.7]	ø0.38 [ø9.7]	ø0.66 [ø16.8]	0.16 [4.1]
DFM-3	4.63 [117.6]	3.00 [76.2]	0.38 [9.7]	3.88 [98.6]	0.38 [9.7]	2.19 [55.6]	1.22 [31.0]	2.19 [55.6]	0.41 [10.4]	ø1.74 [ø44.2]	ø0.38 [ø9.7]	ø0.38 [ø9.7]	ø0.66 [ø16.8]	0.16 [4.1]
DFM-4	5.50 [139.7]	3.75 [95.3]	0.63 [16.0]	4.69 [119.1]	0.41 [10.4]	2.75 [69.9]	1.38 [35.1]	2.75 [69.9]	0.50 [12.7]	ø2.03 [ø51.6]	ø0.44 [ø11.2]	ø0.40 [ø10.2]	ø0.75 [ø19.8]	ø0.36 [ø9.1]
DFM-5	6.25 [158.8]	4.50 [114.3]	0.63 [16.0]	5.44 [138.2]	0.41 [10.4]	3.33 [84.6]	1.46 [37.1]	3.33 [84.6]	0.59 [15.0]	ø2.03 [ø51.6]	ø0.44 [ø11.2]	ø0.40 [ø10.2]	ø0.78 [ø19.8]	ø0.36 [ø9.1]