

# Analog Input Modules

## P3-08THM



### Thermocouple Analog Input

The P3-08THM Thermocouple Input Module provides eight differential channels for receiving thermocouple and voltage input signals.



Patent-pending LCD gives access to field signal values, as well as module and signal faults.

Terminal Block P3-RTB and Cover included. Not compatible with Z/Link.

### T/C Input Specifications

Input channels	8 differential
Data Format	Floating point
Common Mode Range	± 1.25V
Common Mode Rejection	100dB @ DC and 130dB @ 60Hz
Input Impedance	>5M ohms
Maximum Ratings	Fault-protected inputs to ±50VDC
Resolution	16-bit, ± 0.1°C or °F
Thermocouple Input Ranges	Type J -190° to 760°C (-310° to 1400°F); Type E -210° to 1000°C (-346° to 1832°F); Type K -150° to 1372°C (-238° to 2502°F); Type R 65° to 1768°C (149° to 3214°F); Type S 65° to 1768°C (149° to 3214°F); Type T -230° to 400°C (-382° to 752°F); Type B 529° to 1820°C (984° to 3308°F); Type N -70° to 1300°C (-94° to 2372°F); Type C 65° to 2320°C (149° to 4208°F);
Cold Junction Compensation	Automatic
Thermocouple Linearization	Automatic
Accuracy vs. Temperature	±50PPM / °C Maximum
Linearity Error	±1°C Maximum (±0.5°C typical), Monotonic with no missing codes
Maximum Inaccuracy	±3°C Max (excluding thermocouple error) (including temperature drift)
Warm-up Time	30 Minutes for ±1°C Repeatability 2 minutes to reach voltage specifications
Sample Duration Time	270ms
All Channel Update Rate	2.16s
Open Circuit Detection Time	Within 2s
Conversion Method	Sigma-Delta
External DC Power	NONE

### Voltage Input Specifications

Linear mV Device Input Ranges	0-39.0625 mVDC, +/-39.0625 mVDC, +/-78.125 mVDC, 0-156.25 mVDC, +/-156.25 mVDC, 0-1250 mVDC
Max Voltage Input Offset Error	0.05% @ 0° - 60°C, typical 0.04% @ 25°C
Max Voltage Input Gain Error	0.06% @ 25°C
Max Voltage Input Linearity Error	0.05% @ 0° - 60°C, typical 0.03% @ 25°C
Max Voltage Input Inaccuracy	0.2% @ 0° - 60°C, typical 0.06% @ 25°C

### Removable Terminal Block Specifications

Description	Part No. P3-RTB; 20 screw terminals
Wire Range	22-14 AWG (0.324 to 2.08 sq. mm) Solid / stranded conductor 3/64 in. (1.2 mm) insulation maximum "USE COPPER CONDUCTORS, 60°C" or equivalent.*
Screw Driver Width	1/4 inch (6.5 mm) maximum
Screw Size	M3 size
Screw Torque	Field terminals – 7 - 9 in./lb (.0882 - 1.02 Nm) Self-jacking screws – 2.7 - 3.6 in./lb (0.3 - 0.4 Nm). Do not overtighten screws when installing terminal block.

\* Use shielded, twisted thermocouple wire that matches the thermocouple type.

### Configuration/Diagnostics

Burn-out Detection Enable/Disable	1-bit per module
°C/°F (T/C only)	1 bit per module
Module Diagnostics Failure	1 bit per module
Burn-out (on if T/C input is open – no connection between TCn+ and TCn-)	1 bit per channel
Channel Under-range (T/C only)	1 bit per channel
Channel Over-range (T/C only)	1 bit per channel

# Analog Input Modules

## P3-08THM (cont'd)

General Specifications	
Operating Temperature	0° to 60°C (32° to 140°F)
Storage Temperature	-20° to 70°C (-4° to 158°F)
Humidity	5 to 95% (non-condensing)
Environmental Air	No corrosive gases permitted
Vibration	IEC60068-2-6 (Test Fc)
Shock	IEC60068-2-27 (Test Ea)
Field to Logic Side Isolation	1800VAC applied for 1 second
Insulation Resistance	>10MΩ @ 500 VDC
Heat Dissipation	0.36 W
Enclosure Type	Open Equipment
Agency Approvals	UL508 file E157382, Canada & USA UL1604 file E200031, Canada & USA CE (EN61131-2*) This equipment is suitable for use in Class 1, Division 2, Groups A, B, C and D or non-hazardous locations only.
Module Keying to Backplane	Electronic
Module Location	Any I/O slot in any local, expansion, or remote base in a Productivity3000 System.
Field Wiring	Removable terminal block (included). The P3-08THM module is not compatible with the ZIPLink wiring system.
EU Directive	See the "EU Directive" topic in the Productivity3000 Help File. Information can also be obtained at: <a href="http://www.productivitypac.com">www.productivitypac.com</a>
Terminal Type	20-position removable terminal block (included)
Weight	150g (5.3 oz)

\*Meets EMC and Safety requirements. See the Declaration of Conformity for details.

**WARNING:** Explosion hazard – Substitution of components may impair suitability for Class 1, Division 2.

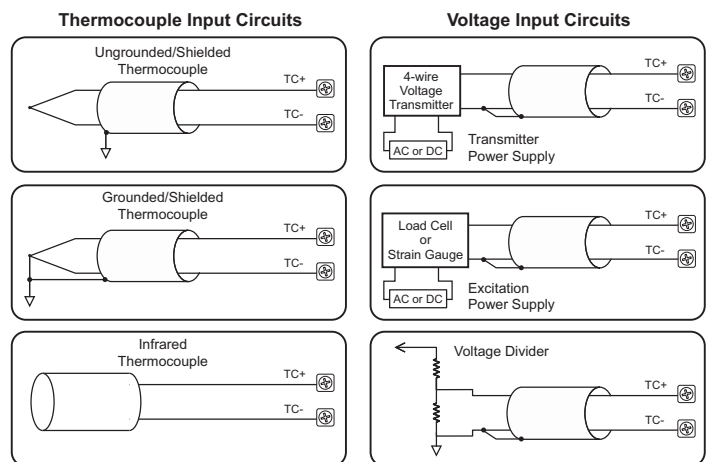
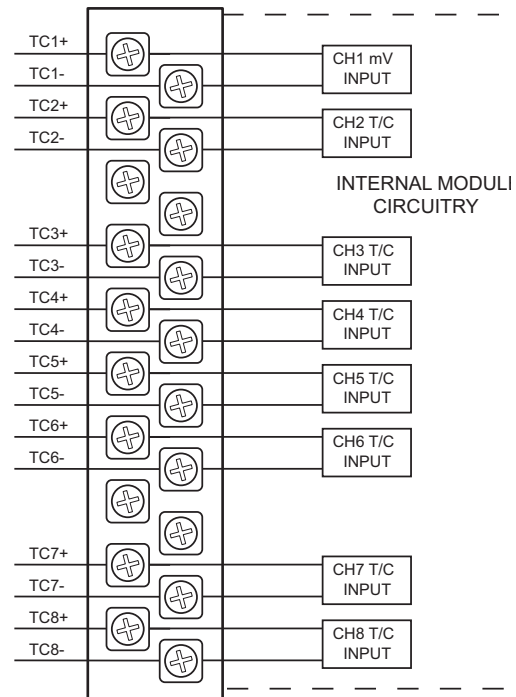

### NOTES:

1. Connect shield to thermocouple signal/ground only. Do not connect to both ends.
2. Install jumper wire on each unused input, TC+ to TC-.
3. With grounded thermocouples, take precautions to prevent having a voltage potential between thermocouple tips. A voltage of 1.25V or greater between tips will skew measurements.
4. Use shielded, twisted thermocouple extension wire that matches the thermocouple type. Use thermocouple-compatible junction blocks.

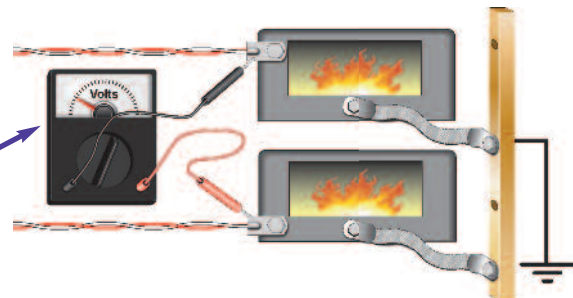

# I/O Modules

A variety of discrete and analog I/O modules are available for use in local, expansion, and remote I/O bases. Specifications for each module are on the following pages.

A filler module is available for unused I/O module slots (part number P3-FILL).



## Discrete Input Modules

Productivity3000 Discrete Input Modules			
Part Number	Number of Inputs	Description	Price
P3-16SIM	16	Input Simulator Module	<--->
P3-08ND3S	8	Isolated Sinking/Sourcing DC Input	<--->
P3-16ND3	16	Sinking/Sourcing DC Input	<--->
P3-32ND3*	32	Sinking/Sourcing DC Input	<--->
P3-64ND3*	64	Sinking/Sourcing DC Input	<--->
P3-08NAS	8	Isolated AC Input	<--->
P3-16NA	16	AC Input	<--->

\* ZIPLink required.

## Analog I/O Modules

Productivity3000 Analog Input Modules			
Part Number	Number of Channels	Description	Price
P3-04ADS	4	Isolated Analog Input	<--->
P3-08AD	8	Analog Input	<--->
P3-16AD-1	16	Analog Input (Current)	<--->
P3-16AD-2	16	Analog Input (Voltage)	<--->
P3-08RTD	8	Analog RTD Input	<--->
P3-08THM	8	Analog Thermocouple Input	<--->

Productivity3000 Analog Output Modules			
Part Number	Number of Channels	Description	Price
P3-04DA	4	Analog Output	<--->
P3-08DA-1	8	Analog Output (Current)	<--->
P3-08DA-2	8	Analog Output (Voltage)	<--->
P3-06DAS-1	6	Isolated Analog Output (Current)	<--->
P3-06DAS-2	6	Isolated Analog Output (Voltage)	<--->
P3-16DA-1	16	Analog Output (Current)	<--->
P3-16DA-2	16	Analog Output (Voltage)	<--->

Productivity3000 Analog Input/Output Modules			
Part Number	Number of Channels	Description	Price
P3-8AD4DA-1	8/4	Analog Input/Output (Current)	<--->
P3-8AD4DA-2	8/4	Analog Input/Output (Voltage)	<--->

## Discrete Output Modules

Productivity3000 Discrete Output Modules			
Part Number	Number of Outputs	Description	Price
P3-08TD1S	8	Isolated Sinking Output	<--->
P3-08TD2S	8	Isolated Sourcing Output	<--->
P3-16TD1	16	Sinking Output	<--->
P3-16TD2	16	Sourcing Output	<--->
P3-32TD1*	32	Sinking Output	<--->
P3-32TD2*	32	Sourcing Output	<--->
P3-64TD1*	64	Sinking Output	<--->
P3-64TD2*	64	Sourcing Output	<--->
P3-08TAS	8	Isolated AC Output	<--->
P3-16TA	16	AC Output	<--->
P3-08TRS	8	Isolated Relay Output	<--->
P3-16TR	16	Relay Output	<--->
P3-08TRS-1	8	Isolated Relay Output	<--->

\* ZIPLink required.

## Module Installation Procedure

**WARNING:** Do not apply field power until the following steps are completed. See hot-swapping procedure for exceptions.

**Step One:** Align circuit card with slot and press firmly to seat module into connector.

**Step Two:** Pull top and bottom locking tabs toward module face. Click indicates lock is

**Step Three:** Attach field wiring using optional terminal block or ZIPLink wiring system and install cover.

To install or remove terminal block cover, press middle to flex cover.

**WARNING:** Explosion hazard – Do not connect or disconnect connectors or operate switches while circuit is live unless the area is known to be non-hazardous. Do not hot-swap modules unless the area is known to be non-hazardous.