



Packaged M.O.V.s and Diodes

Overview

Metal Oxide Varistors (MOV) and Diode circuits are offered as convenient plug-in modules. Plugging a module into the relay socket connects the circuit in parallel with the relay coil. No additional wiring is required.

Modules fit within the maximum dimensions of the relay and socket.

Features

- MOVs protect by shunting potentially damaging electrical spikes away from the relay coil. Ideal for AC and DC applications.
- Diodes protect external drive circuitry from inductive voltages generated when removing coil voltage. Ideal for DC applications. Polarity sensitive.

Application

Many PLC systems control one or more inductive load devices. These inductive loads (devices with a coil) generate transient voltages when they are de-energized with a relay contact. When a relay contact is closed it “bounces”, which causes the coil to energize and de-energize until the “bouncing” stops. The transient voltage which is generated is much larger in amplitude than the supply voltage, especially with a DC supply voltage.

When switching a DC-supplied inductive load the full supply voltage is always present when the relay contact opens (or “bounces”). When switching an AC-supplied inductive load, if the voltage is not zero when the relay contact opens, there is energy stored in the inductor that is released when the voltage to the inductor is suddenly removed. This release of energy is what produces transient voltages.



When inductive load devices (motors, motor starters, interposing relays, solenoids, valves, etc.) are controlled with relay contacts, it is recommended that a surge suppression device be connected directly across the coil of the field device. If the inductive device has plug-type connectors, the suppression device can be installed on the terminal block of the relay output.

Metal oxide varistors (MOV) and diodes are devices which provide good surge and transient suppression of AC and DC powered coils.

Protection Device Selection Guide

Part Number	Price	Description	Nominal Input Voltage	Dimensions & Package	Mating Socket
AD-ASMD-250	<--->	Protection diode module for 784 and 75 series relays. Plug-in modules come in package of 5.	6-250VDC	Figure 1	783-3C-SKT 784-4C-SKT-1 750-2C-SKT 750-3C-SKT
AD-ASMM-24		MOV module for 784 and 75 series relays that operate at 24VAC coil voltage. Package includes 5 modules.	24VAC/VDC		
AD-ASMM-120		MOV module for 784 and 75 series relays that operate at 120VAC coil voltage. Package includes 5 modules.	120VAC/VDC		
AD-ASMM-240		MOV module for 784 and 75 series relays that operate at 240VAC coil voltage. Package includes 5 modules.	240VAC/VDC		
AD-BSMD-250	<--->	Protection diode module for 782 series relays. Plug-in modules come in package of 5.	6-250VDC	Figure 2	782-2C-SKT
AD-BSMM-24		MOV module for 782 series relays that operate at 24VAC coil voltage. Package includes 5 modules.	24VAC/VDC		
AD-BSMM-120		MOV module for 782 series relays that operate at 120VAC coil voltage. Package includes 5 modules.	120VAC/VDC		
AD-BSMM-240		MOV module for 782 series relays that operate at 240VAC coil voltage. Package includes 5 modules.	240VAC/VDC		

Accessory dimensions

inches [mm]

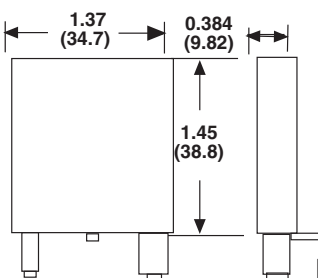

Figure 1

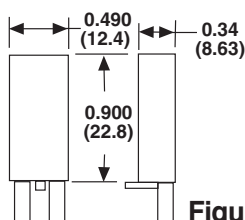
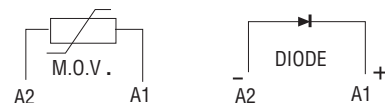

Figure 2





Company Information

Systems Overview

Programmable Controllers

Field I/O

Software

C-more & other HMI

Drives

Soft Starters

Motors & Gearbox

Steppers/ Servos

Motor Controls

Proximity Sensors

Photo Sensors

Limit Switches

Encoders

Current Sensors

Pressure Sensors

Temperature Sensors

Pushbuttons/ Lights

Process

Relays/ Timers

Comm.

Terminal Blocks & Wiring

Power

Circuit Protection

Enclosures

Tools

Pneumatics

Appendix

Product Index

Part # Index

78 Series Relay Socket Dimensions

Dimensions

inches [mm]

Figure 5: 781-1C-SKT

DIN-rail mounting, SPDT, for use with 781 series relays

Note: See Table on next page for maximum screw torques and wire sizes

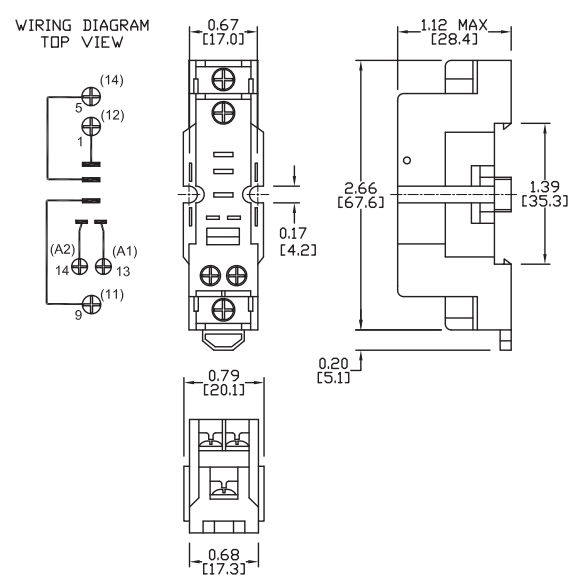

Figure 6: 782-2C-SKT

DIN-rail mounting, DPDT, for use with 782 series and AD-70S2 relays

Note: See Table on next page for maximum screw torques and wire sizes

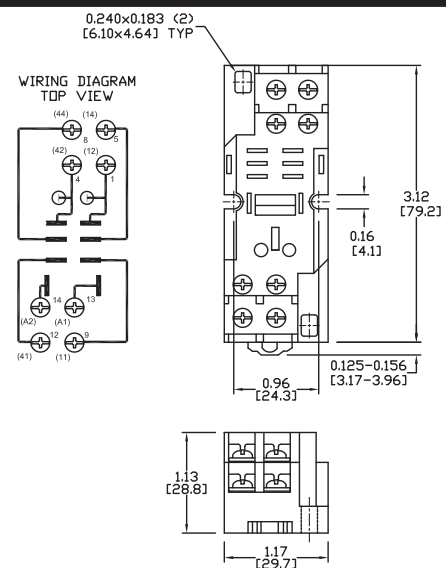
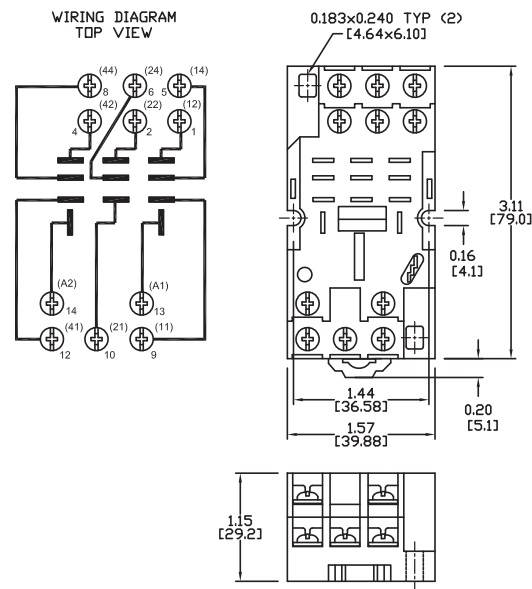

Figure 7: 783-3C-SKT

DIN-rail mounting, 3PDT, for use with 783 series relays.

Note: See Table on next page for maximum screw torques and wire sizes



Note: Order sockets separately; holding clips are included with sockets.

78 Series Relay Socket Dimensions



Dimensions

inches [mm]

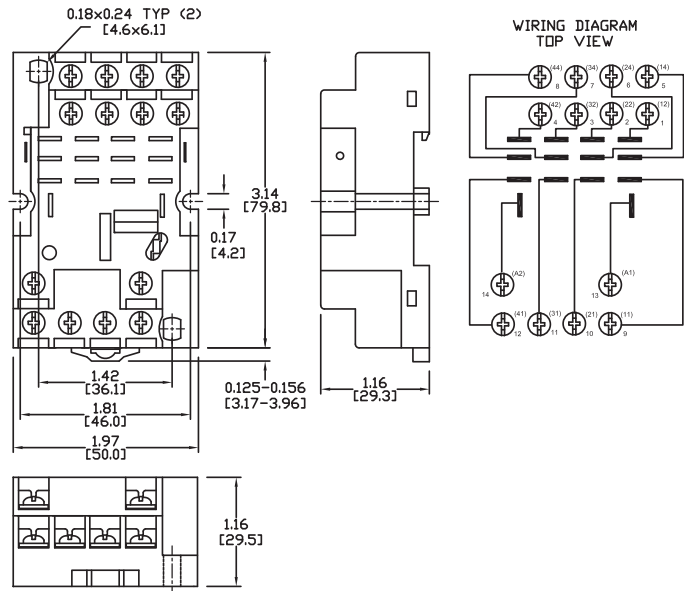

Figure 8: 784-4C-SKT-1

DIN-rail mounting, 4PDT,
for use with 784 series relays.

Note: Order sockets separately;
holding clips are included with sockets.

Note: See table below for maximum screw
torques and wire sizes

Part Number	Maximum Screw Torques	Maximum Wire Sizes
781-1C-SKT	Terminals 13, 14: 7 in-lbs/0.8Nm Terminals 1, 5, 9: 9 in-lbs/1.0Nm	Terminals 13, 14: 18 to 20 AWG, solid or stranded, one or two identical wires Terminals 1, 5, 9: 12 to 20 AWG, solid or stranded, one or two identical wires
782-2C-SKT	All terminals: 9 in-lbs/1.0Nm	All terminals: 12 to 20 AWG, solid or stranded, one or two identical wires
783-3C-SKT		
784-4C-SKT-1		