

# RHINO PSB Series DIN rail Power Supplies

AutomationDirect's RHINO PSB series of DIN rail power supplies is perfect for applications that require a basic DC voltage power supply. These low cost power supplies offer high performance and reliability without all the additional features of higher cost full-featured power supplies. The RHINO PSB series is available with universal single- and three-phase input and with output voltages of 12 and 24 VDC from 15 to 480 Watts. The rugged plastic and aluminum housings easily install with integral 35mm DIN rail mounting adapters. These high-quality power supplies include overload, overvoltage and thermal protection, and are UL 508 listed, UL 60950 recognized, CSA certified, CE marked and RoHS compliant.

## Features

- Universal input voltage, 85-264 VAC / 120-375 VDC single phase or 320-575 VAC 3-phase
- 24 VDC or 12 VDC outputs, 15 to 480 Watts
- Adjustable output voltage
- Rugged plastic or aluminum housings with integral 35mm DIN rail mounting adapters
- Output voltage status LED
- Robust fixed-screw terminal strips with finger-safe covers
- Overload, overvoltage and thermal protection
- UL 508 listed, UL 60950 recognized, CSA certified, CE marked and RoHS compliant
- Three year warranty



PSB Single-Phase Series Input Specifications												
Part No.	Price	Weight	Housing	Input Voltage	Input Frequency Range	Nominal Current	Inrush Current Limitation $P_t$ @ 77°F (+25°C) typ.	Leakage Current	Recommended Circuit Breaker*	Mains Buffering at Nominal Load (Typ.)	Turn-on Time	
PSB12-015-P	<--->	0.175 kg (0.39 lb)	Plastic	85-264 VAC (DC input range 120-375 VDC); Nominal 100-240 VAC	47-63 Hz (0 Hz @ DC Input)	0.37A @ 115 VAC, 0.22A @ 230 VAC	<30A @ 115 VAC, <65A @ 230 VAC	<1 mA	6A	>22 ms @ 115 VAC, >110 ms @ 230 VAC	<2.5 sec.	
PSB12-030-P	<--->	0.197 kg (0.43 lb)	Plastic			0.7A @ 115 VAC, 0.42A @ 230 VAC	<40A @ 115 VAC, <80A @ 230 VAC					
PSB12-060	<--->	0.325 kg (0.72 lb)	Aluminum			1.35A @ 115 VAC 0.8A @ 230 VAC	<50A @ 115 VAC, <100A @ 230 VAC					
PSB12-100	<--->	0.636 kg (1.40 lb)	Aluminum			2.5A @ 115 VAC 1.5A @ 230 VAC	<100A @ 115 VAC, no damage @ 230 VAC		16A	<3.5 mA	>20 ms @ 115 VAC, >125 ms @ 230 VAC	<3 sec.
PSB24-060	<--->	0.37 kg (0.82 lb)	Aluminum			1.1A @ 115 VAC 0.7A @ 230 VAC	<40A @ 115 VAC, <80A @ 230 VAC					
PSB24-060-P	<--->	0.325 kg (0.72 lb)	Plastic			1.1A @ 115 VAC 0.7A @ 230 VAC	<40A @ 115 VAC, <80A @ 230 VAC					
PSB24-120	<--->	0.54 kg (1.19 lb)	Aluminum			1.4A @ 115 VAC 0.8A @ 230 VAC	<80A @ 115 VAC, <150A @ 230 VAC		<1.25 mA	>20 ms @ 115 VAC & 230 VAC	<1 sec.	
PSB24-240	<--->	1.04 kg (2.29 lb)	Aluminum			2.9A @ 115 VAC 1.5A @ 230 VAC	<40A @ 115 VAC, <100A @ 230 VAC					
PSB24-480	<--->	1.8 kg (3.97 lb)	Aluminum			5.7A @ 115 VAC 2.8A @ 230 VAC	<50A @ 115 VAC, <150A @ 230 VAC					

\*Characteristic B



# RHINO PSB Series DIN rail Power Supplies

- Company Information
- Systems Overview
- Programmable Controllers
- Field I/O
- Software
- C-more & other HMI
- Drives
- Soft Starters
- Motors & Gearbox
- Steppers/ Servos
- Motor Controls
- Proximity Sensors
- Photo Sensors
- Limit Switches
- Encoders
- Current Sensors
- Pressure Sensors
- Temperature Sensors
- Pushbuttons/ Lights
- Process
- Relays/ Timers
- Comm.
- Terminal Blocks & Wiring
- Power
- Circuit Protection
- Enclosures
- Tools
- Pneumatics
- Safety
- Appendix
- Product Index
- Part # Index

## PSB Single-Phase Series Output Specifications

Part No.	Output Voltage (Vnom) / Adjustment Range	Output Power	Output Current	Ripple and Noise (20MHz)	Startup with Capacitive Loads	Derating above 50°C (122°F)	Max Power Dissipation Idling / Nominal Load Approx.	Efficiency (at 400 VAC and Nominal Values)	MTBF
<b>PSB12-015-P</b>	12 VDC ±2%/11-14VDC (maximum power <15W)	15 Watt	1.25A	<100mV	Max 5,000 µF	2.5%/°C. (>70°C [158°F] 4%/°C)	≤ 3.2 Watts	83.5% Min @ 115VAC & 83% Min @ 230VAC	>300,000 hrs.
<b>PSB12-030-P</b>	12 VDC ±2%/11-14VDC (maximum power ≤30W)	30 Watt	2.5A		Max 6,600 µF		≤ 5.6 Watts	84.5% Min @ 115VAC & 230VAC	
<b>PSB12-060</b>	12 VDC ±2%/11-14VDC (maximum power ≤60W)	60 Watt	5A		Max 8,000 µF		≤ 10.2 Watts	85.5% Min @ 115VAC & 230VAC	
<b>PSB12-100</b>	12 VDC ±2%/11-14VDC (maximum power ≤100W)	100 Watt	8.33A		Max 10,000 µF		≤ 16.3 Watts	86% Min @ 115VAC & 87% Min @ 230VAC	
<b>PSB24-060</b>	24 VDC ±2%/22-28VDC (maximum power ≤60W)	60 Watt	2.5A	<50mV / <240mVpp	Max 8,000 µF	2.5%/°C. (<0° [32°F] 1%/°C)	10 Watts	>85% typical	>800,000 hrs.
<b>PSB24-060-P</b>	24 VDC ±2%/22-28VDC (maximum power ≤60W)	60 Watt	2.5A		Max 10,000 µF	2.5%/°C. (>70° [158°F] 4%/°C)	42.5 Watts	>84% typical	
<b>PSB24-120</b>	24 VDC ±2%/22-28VDC (maximum power ≤120W)	120 Watt	5A		2.5%/°C.	22.5 Watts	>84% typical		
<b>PSB24-240</b>	24 VDC ±2%/22-28VDC (maximum power ≤240W)	240 Watt	10A		2.5%/°C. (>70° [158°F] 4%/°C)	42.5 Watts	>84% typical		
<b>PSB24-480</b>	24 VDC ±2%/22-28VDC (maximum power ≤480W)	480 Watt	20A	2.5%/°C.	72 Watts	>86% typical	>300,000 hrs.		

## PSB Single-Phase Series General Specifications

<b>Output Line Regulation</b>	<0.5% typical (@ 85-264 VAC input, 100% load)
<b>Output Load Regulation</b>	<1% typical (@ 85-264 VAC input, 0-100% load)
<b>Parallel Operation</b>	With decoupling diode
<b>Case Cover</b>	Aluminium (Al5052) or Plastic (PC), for P Series (closed)
<b>Signals</b>	Green LED DC OK
<b>Humidity at 25°C (77°F), no condensation</b>	<95% RH
<b>Shock</b>	30g half sign, 3 times per direction, 6 directions, per IEC60068-2-27
<b>Vibration (Non-Operating)</b>	10 to 150Hz, 5 g, 90 min. each axis per IEC60068-2-6
<b>Pollution Degree</b>	2
<b>Climatic Class</b>	3K3 according to EN 60721

## PSB Single-Phase Series Certification and Standards

<b>Electrical Equipment of Machines</b>	IEC60204-1 (over voltage category III)
<b>Electronic Equipment for use in Electrical Power Installations</b>	EN 50178 / IEC62103
<b>Safety Entry Low Voltage</b>	PELV (EN 60204), SELV (EN 60950)
<b>Electrical Safety (of information technology equipment)</b>	UL/C-UL recognized to UL60950-1 (#E198298), CSA C22.2 No.60950-1 (#249074), CB scheme to IEC60950-1
<b>Industrial Control Equipment</b>	UL listed to UL508 (#E197592), CSA to CSA C22.2 No.107.1-01 (#249074)
<b>Protection Against Electric Shock</b>	DIN 57100-410
<b>CE</b>	In conformance with EMC directive 2004/108/EC and low voltage directive 2006/95/EC

## PSB Single-Phase Series Safety and Protection

<b>Transient surge voltage protection</b>	VARISTOR
<b>Overload/Short Circuit Protection</b>	<150% rated load current, hiccup mode with automatic recovery
<b>Overvoltage Protection</b>	35 VDC max.
<b>Isolation Voltage::</b> <b>Input/output (type test/routine test)</b> <b>Input/GND (type test/routine test)</b> <b>Output/GND (type test/routine test)</b>	4 kVAC / 3 kVAC 1.5 kVAC / 1.5 kVAC 1.5 kVAC / 500 VAC
<b>Protection Degree</b>	IPX0
<b>Safety Class</b>	Class I with GND connection

# RHINO PSB Series DIN rail Power Supplies

Additional Data				
Part No.	Dimensions (L x W x H)	Wire Size / Torque*	Ambient Operating Temperature	Storage Temperature
<b>PSB12-015-P</b> <b>PSB12-030-P</b>	100 mm x 32 mm x 100 mm (3.94 in x 1.26 in x 3.94 in)	0.32-2.1 mm <sup>2</sup> (AWG 22-14) / 0.79Nm (7.0 lb-in)		
<b>PSB12-060</b>	121 mm x 32 mm x 120 mm (4.76 in x 1.26 in x 4.72 in)	0.52-2.1 mm <sup>2</sup> (AWG 20-14) / 0.78-0.98Nm (6.94-8.68 lb-in)	-20°C to 50°C (-4°F to 122°F)	-25°C to 85°C (-13°F to 185°F)
<b>PSB12-100</b>	121 mm x 50 mm x 118.2 mm (4.76 in x 1.97 in x 4.65 in)	0.82-2.1 mm <sup>2</sup> (AWG 18-14) / 0.78-0.98Nm (6.94-8.68 lb-in)		
<b>PSB24-060</b>	121 mm x 32 mm x 120 mm (4.76 in x 1.26 in x 4.72 in)			
<b>PSB24-060-P</b>	126 mm x 32 mm x 113 mm (4.96 in x 1.26 in x 4.45 in)	0.32-2.1 mm <sup>2</sup> (AWG 22-14) / 0.78-0.98Nm (6.94-8.68 lb-in)		
<b>PSB24-120</b>	121 mm x 50 mm x 118.2 mm (4.76 in x 1.97 in x 4.65 in)		-20°C to 75°C (>50°C [122°F] derating) [-4°F to 167°F]	-25°C to 85°C (-13°F to 185°F)
<b>PSB24-240</b>	121 mm x 85 mm x 118.2 mm (4.76 in x 3.35 in x 4.65 in)			
<b>PSB24-480</b>	121 mm x 160 mm x 115 mm (4.76 in x 6.30 in x 4.53 in)	(1) 1.3-2.1mm <sup>2</sup> (AWG 16-14) (2) 3.5-5.3mm <sup>2</sup> (AWG 12-10) / 1.18-1.57Nm (10.41-13.89 lb-in)		

\*Stripping length 7 mm (0.28 in) or use suitable lug to crimp

## Dimensions

All dimensions in mm [inches]

**PSB12-015-P**  
**PSB12-030-P**

Wiring Connection			
Input		Output	
L	Line	+	Out +
N	Neutral	-	Out -
⊥	AC Ground		

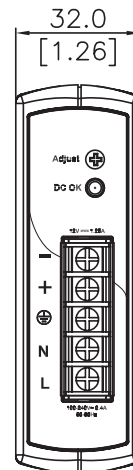
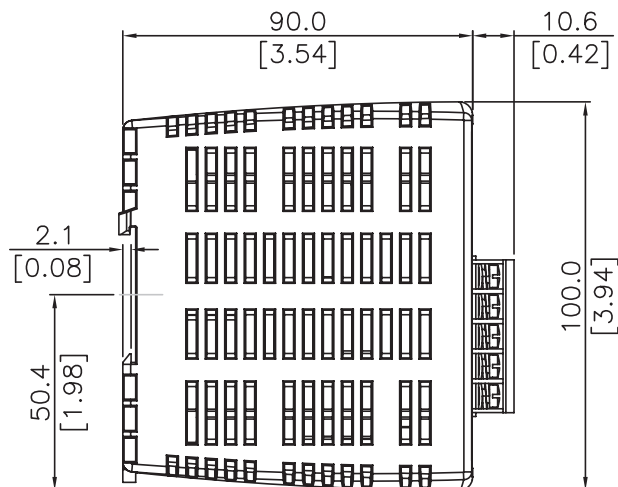
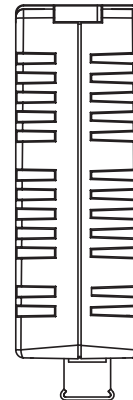

# RHINO PSB Series DIN rail Power Supply Dimensions

**PSB12-060**  
**PSB24-060**

Wiring Connection			
Input		Output	
L	Line	+	Out +
N	Neutral	-	Out -
⊥	AC Ground		

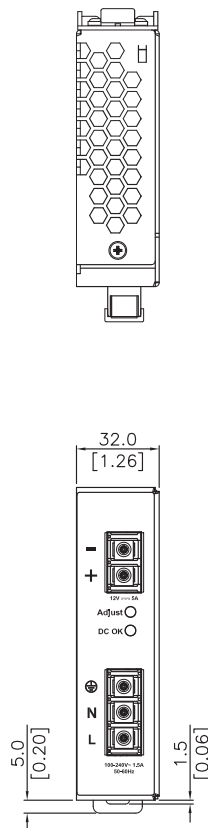
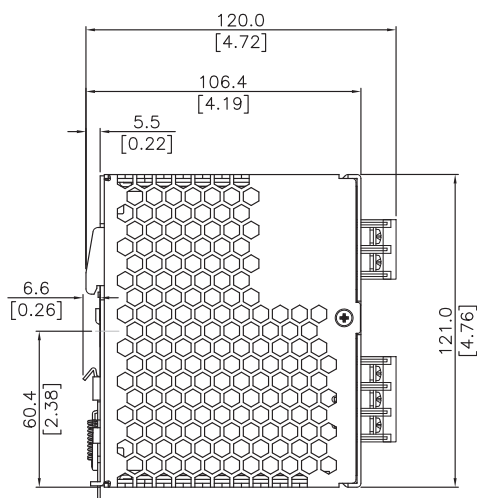

**PSB12-100**  
**PSB24-120**

Wiring Connection			
Input		Output	
L	Line	+	Out +
N	Neutral	-	Out -
⊥	AC Ground		

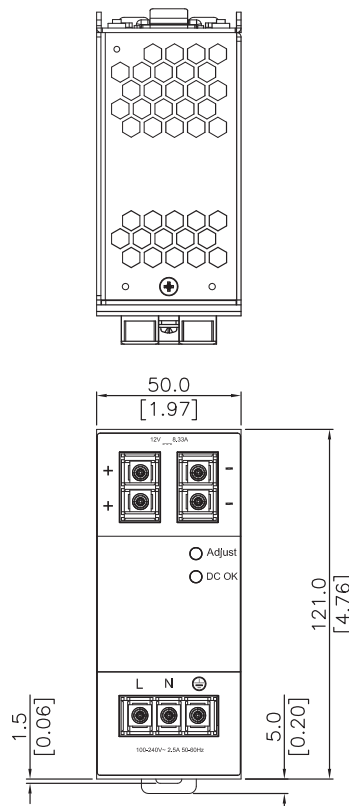
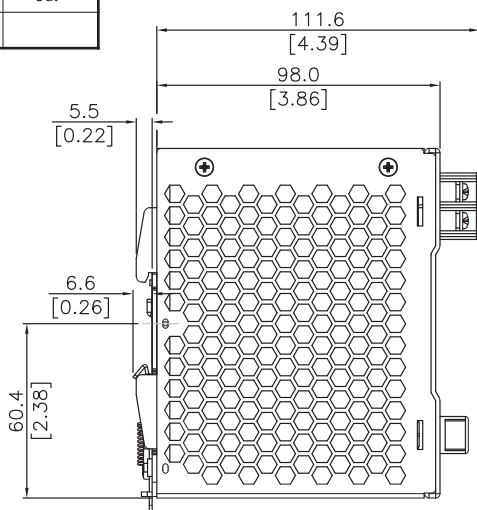

All dimensions in mm [inches]

# RHINO PSB Series DIN rail Power Supply Dimensions

## PSB24-060-P

Wiring Connection			
Input		Output	
L	Line	+	Out +
N	Neutral	-	Out -
	AC Ground		

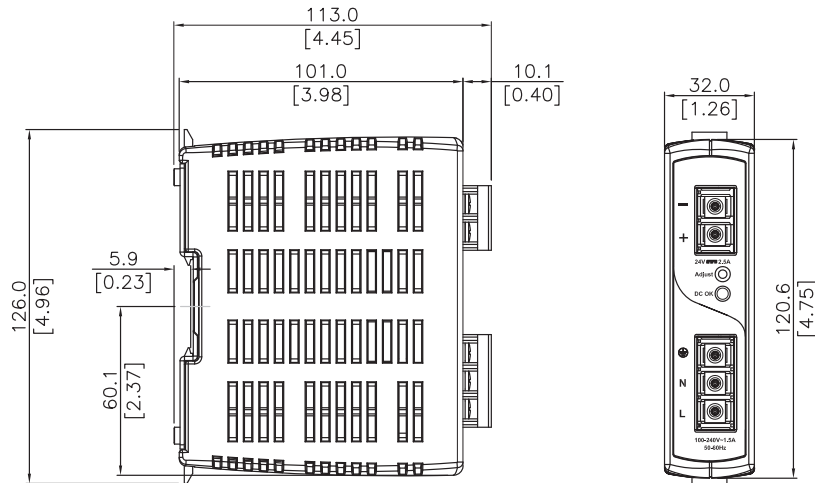
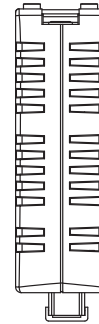

## PSB24-240

Wiring Connection			
Input		Output	
L	Line	+	Out +
N	Neutral	-	Out -
	AC Ground		

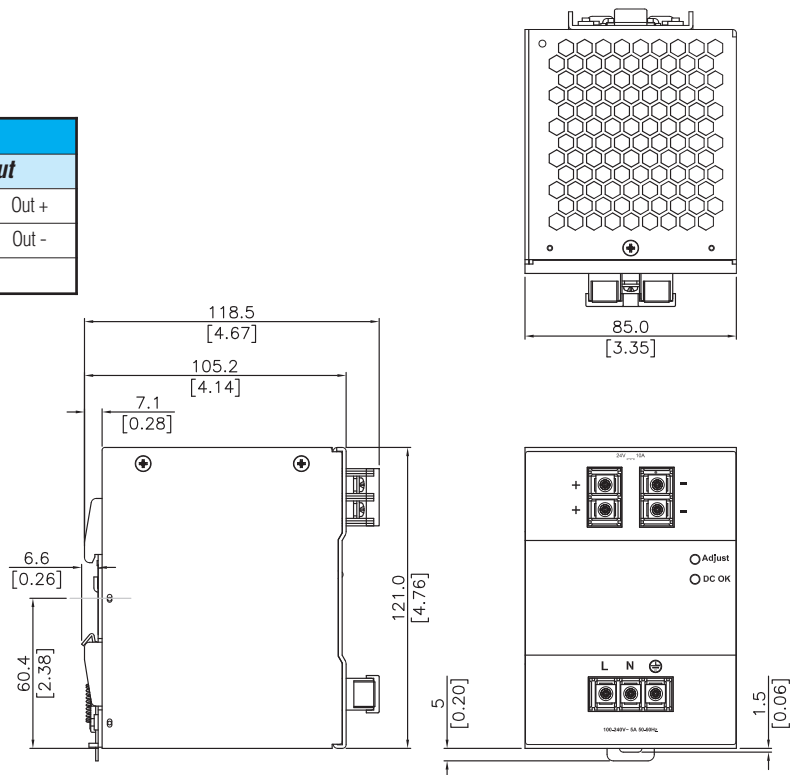

All dimensions in mm [inches]

# RHINO PSB Series DIN rail Power Supply Dimensions

## PSB24-480

Wiring Connection			
Input		Output	
L	Line	+	Out +
N	Neutral	-	Out -
$\perp$	AC Ground		

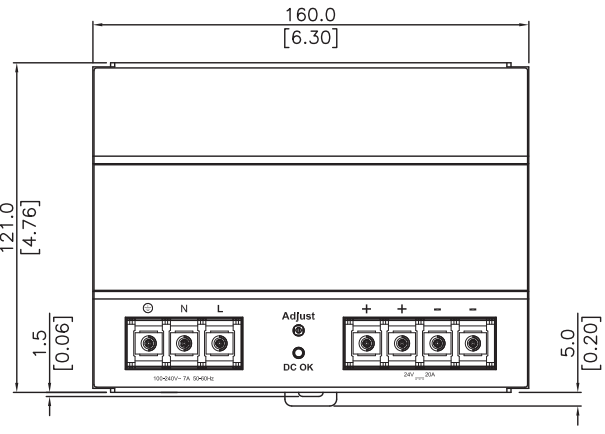
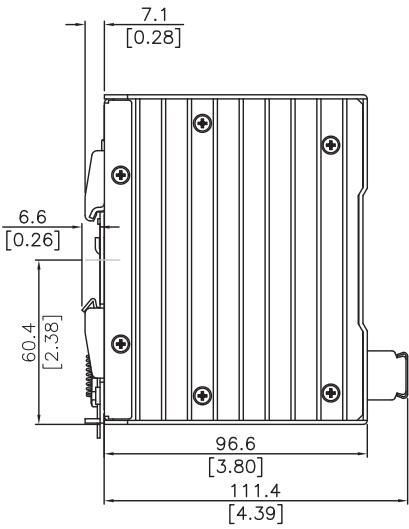
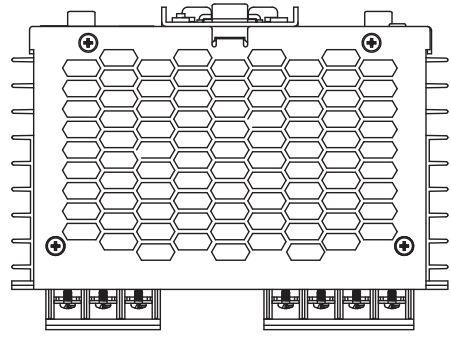

All dimensions in mm [inches]

- Company Information
- Systems Overview
- Programmable Controllers
- Field I/O
- Software
- C-more & other HMI
- Drives
- Soft Starters
- Motors & Gearbox
- Steppers/ Servos
- Motor Controls
- Proximity Sensors
- Photo Sensors
- Limit Switches
- Encoders
- Current Sensors
- Pressure Sensors
- Temperature Sensors
- Pushbuttons/ Lights
- Process
- Relays/ Timers
- Comm.
- Terminal Blocks & Wiring
- Power**
- Circuit Protection
- Enclosures
- Tools
- Pneumatics
- Safety
- Appendix
- Product Index
- Part # Index

# RHINO PSB Series DIN rail Power Supplies

## Three-Phase PSB Series Units

AutomationDirect's RHINO PSB series of DINrail three-phase input power supplies is perfect for applications that require a basic DC voltage power supply. These low cost power supplies offer high performance and reliability without all the additional features of higher cost full-featured power supplies. The three-phase input eliminates the need for a separate step-down transformer and the output of 24 VDC is available from 60 to 480 Watts. The rugged aluminum housings easily install with integral 35mm DINrail mounting adapters. These high-quality power supplies have a 3-year warranty, include overload, overvoltage and thermal protection, and are UL 508 listed, UL 60950 recognized, CSA certified, CE marked and RoHS compliant. units are covered by a 3-year warranty.



PSB Three-Phase Series Input Specifications											
Part No.	Price	Weight	Housing	Input Voltage	Input Frequency Range	Nominal Current	Inrush Current Limitation I <sub>2t</sub> @ 77°F (+25°C) typ.	Leakage Current	Recommended Circuit Breaker*	Mains Buffering at Nominal Load (Typ.)	Turn-on Time
PSB24-060-3	<-->	0.56kg (1.23 lb)	Aluminum	320 to 575 VAC (DC input range 450 to 800 VDC), Nominal 3 x 400-500 VAC	47 - 63 Hz (0 Hz @ DC Input)	0.3A @ 400 VAC approx.	<30A @ 400 VAC	<3.5mA	3 x circuit breakers 16A	>30ms @ 3 x 400 VAC, >60ms @ 3 x 500 VAC	<2 sec.
PSB24-120-3	<-->	0.72kg (1.59 lb)	Aluminum			0.5A @ 400 VAC approx.				>35ms @ 3 x 400 VAC, >70ms @ 3 x 500 VAC	
PSB24-240-3	<-->	0.99 kg (2.18 lb)	Aluminum			0.8A @ 400 VAC approx.	<40A @ 400 VAC		>35ms @ 3 x 400 VAC, >60ms @ 3 x 500 VAC	<1 sec.	
PSB24-480-3	<-->	1.71 kg (3.77 lb)	Aluminum			1.6A @ 400 VAC approx.	<50A @ 400 VAC		3 x circuit breakers or fuses, 16A		>25ms @ 3 x 400 VAC, >50 ms @ 3 x 500 VAC

\*Characteristic B

PSB Three-Phase Series Output Specifications									
Part No.	Output Voltage (V <sub>nom</sub> ) / Adjustment Range	Output Power	Output Current	PARD (ripple and noise) (20MHz)	Startup with Capacitive Loads	Derating above +50°C (122°F)	Max Power Dissipation Idling / Nominal Load Approx.	Efficiency (at 400 VAC and Nominal Values)	MTBF
PSB24-060-3	24 VDC ±2% / 22-28 VDC (≤60W)	60 Watt	2.5A	<50mV / <240 mV <sub>pp</sub>	Max 10,000 µF	2.5%/°C	9 Watts	86% min @ 3x400 VAC 85% min @ 3x500 VAC	>500,000 hrs.
PSB24-120-3	24 VDC ±2% / 22-28 VDC (≤120W)	120 Watt	5A				18 Watts		
PSB24-240-3	24 VDC ±2% / 22-28 VDC (≤240W)	240 Watt	10A			2.5%/°C. (>70°C [158°F] 4%/°C)	36 Watts	87% min @ 3x400 VAC 86% min @ 3x500 VAC	>300,000 hrs.
PSB24-480-3	24 VDC ±2% / 22-28 VDC (≤480W)	480 Watt	20A			2.5%/°C	72 Watts	86% min @ 3x400 VAC 85% min @ 3x500 VAC	

PSB Three-Phase Series General Specifications	
Output Line Regulation	<0.5% typical (@ 320-575 VAC input, 100% load)
Output Load Regulation	<1% typical (@ 320-575 VAC input, 0-100% load)
Parallel Operation	With decoupling diode
Case Cover	Aluminium (Al5052)
Signals	Green LED DC OK
Humidity at +25°C (77°F), no condensation	<95% RH
Shock	30g half sign, 3 times per direction, 6 directions, per IEC60068-2-27
Vibration (Non-operating)	10 to 150Hz, 5 g, 90 min. each axis per IEC60068-2-6
Pollution Degree	2
Climatic Class	3K3 according to EN 60721



- Company Information
- Systems Overview
- Programmable Controllers
- Field I/O
- Software
- C-more & other HMI
- Drives
- Soft Starters
- Motors & Gearbox
- Steppers/ Servos
- Motor Controls
- Proximity Sensors
- Photo Sensors
- Limit Switches
- Encoders
- Current Sensors
- Pressure Sensors
- Temperature Sensors
- Pushbuttons/ Lights
- Process
- Relays/ Timers
- Comm.
- Terminal Blocks & Wiring
- Power**
- Circuit Protection
- Enclosures
- Tools
- Pneumatics
- Safety
- Appendix
- Product Index
- Part # Index

# RHINO PSB Series DIN rail Power Supplies

PSB Three-Phase Series Certification and Standards	
Electrical Equipment of Machines	IEC60204-1 (over voltage category III)
Electronic Equipment for use in Electrical Power Installations	EN 50178 / IEC62103
Safety Entry Low Voltage	PELV (EN 60204), SELV (EN 60950)
Electrical Safety (of information technology equipment)	UL/C-UL recognized to UL60950-1(#E198298), CSA C22.2 No.60950-1 (#249074), CB scheme to IEC60950-1
Industrial Control Equipment	UL listed to UL508 (#E197592), CSA to CSA107.1-01 (#249074)
Protection Against Electric Shock	DIN 57100-410
CE	In conformance with EMC directive 2004/108/EC and low voltage directive 2006/95/EC
EMC for ITE	EN 55022, EN 61000-3-2, EN 61000-3-3, EN 55024
EMC for Industrial	EN 55011
Limitation of Mains Harmonic Currents	EN 61000-3-2

PSB Three-Phase Series Safety and Protection	
Transient Surge Voltage Protection	VARISTOR
Overload/Short Circuit Protection	<150% rated load current, hiccup mode with automatic recovery
Overvoltage Protection	35 VDC max.
Isolation Voltage:: Input/output (type test/routine test) Input/GND (type test/routine test) Output/GND (type test/routine test)	4 kVAC / 3 kVAC 1.5 kVAC / 1.5 kVAC 1.5 kVAC / 500 VAC
Protection Degree	IPX0
Safety Class	Class I with GND connection

Additional Data				
Part No.	Dimensions (L x W x H)	Wire Size / Torque *	Ambient Operating Temperature	Storage Temperature
PSB24-060-3	121 mm x 70 mm x 118.5 mm (4.76 in x 2.76 in x 4.67 in)	0.82-2.1mm <sup>2</sup> (AWG 18-14) / 1.18-1.57 Nm (10.41-13.89 lb-in)	-20°C to +75°C (-50°F [122°F] derating) [-4°F to 167°F]	-25°C to +85°C (-13°F to 185°F)
PSB24-120-3		0.82-8.4mm <sup>2</sup> (AWG 18-8) / 1.18-1.57 Nm (10.41-13.89 lb-in)		
PSB24-240-3	121 mm x 85 mm x 120.5 mm (4.76 in x 3.35 in x 4.74 in)			
PSB24-480-3	121 mm x 160 mm x 115 mm (4.76 in x 6.3 in x 4.53 in)	Input - 0.82-2.1mm <sup>2</sup> (AWG 18-14) / 1.18-1.57 Nm (10.41-13.89 lb-in) Output - 3.3 - 5.3mm <sup>2</sup> (AWG12-10) / 1.18-1.57 Nm (10.41-13.89 lb-in)		

\*Stripping length 7 mm (0.28 in) or use suitable lug to crimp

## Dimensions

All dimensions in mm [inches]

**PSB24-060-3**  
**PSB24-120-3**

Wiring Connection			
Input		Output	
L1	Line 1	-V	Out -
L2	Line 2	+V	Out +
L3	Line 3		
⊥	AC Ground		

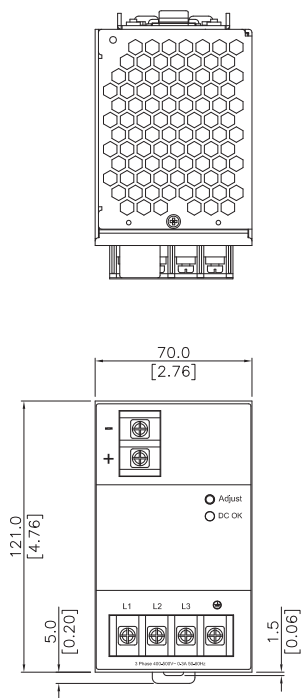
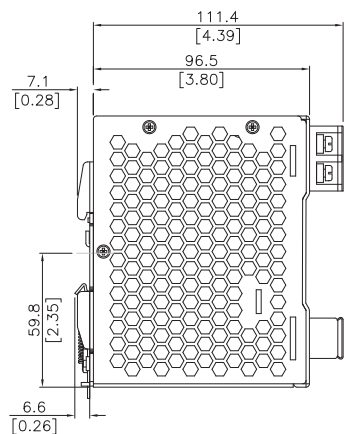

# RHINO PSB Series DIN rail Power Supply Dimensions

## PSB24-240-3

Wiring Connection			
Input		Output	
L1	Line 1	-V	Out -
L2	Line 2	+V	Out +
L3	Line 3		
⏏	AC Ground		

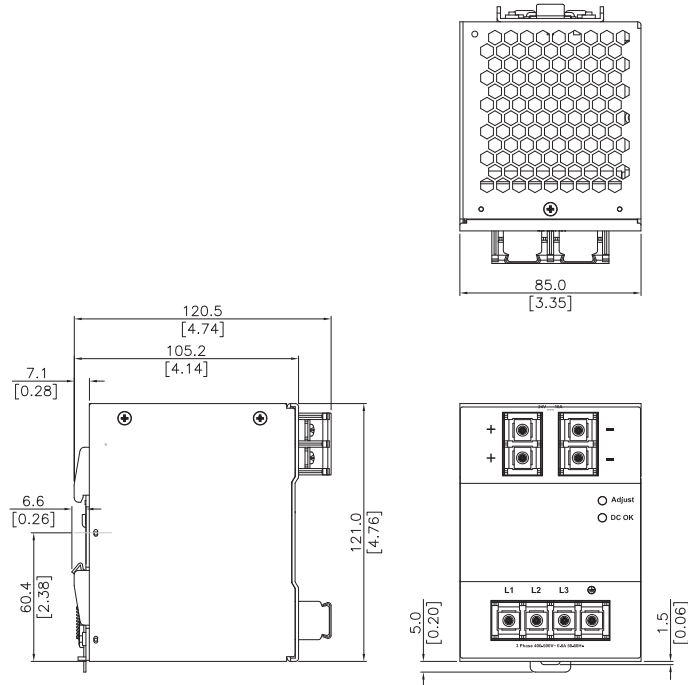

## PSB24-480-3

Wiring Connection			
Input		Output	
L1	Line 1	-V	Out -
L2	Line 2	+V	Out +
L3	Line 3		
⏏	AC Ground		

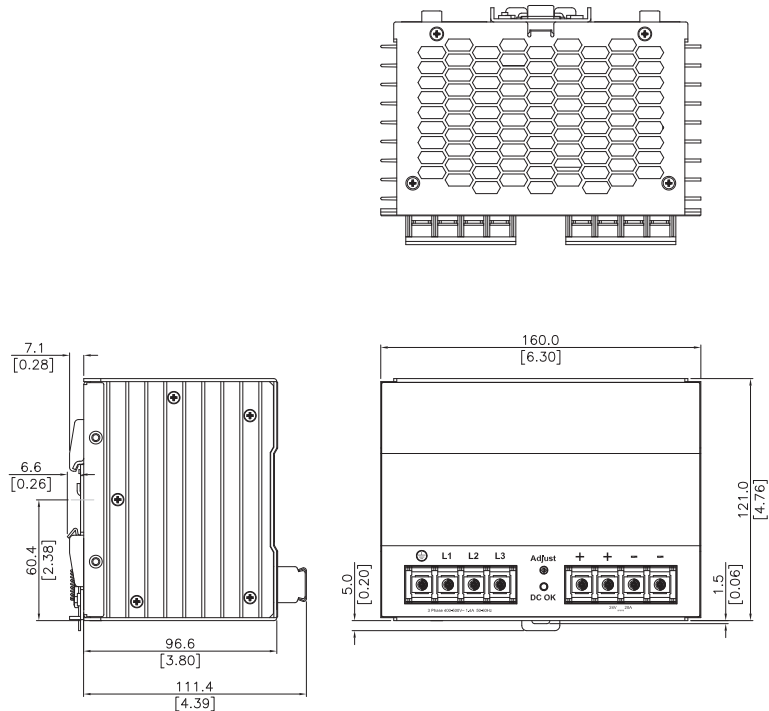

All dimensions in mm [inches]

## PSB Power Supply Accessories

PSB Series Power Supply Accessories		
Part No.	Price	Description
PSB-CVR	<--->	Universal replacement terminal cover kit for all RHINO PSB series power supplies. Universal kit includes (9) terminal covers to replace all terminal covers on any PSB power supply model

