

Stellar SR22 Series Compact Soft Starters

Overview

SR22 semi-conductor soft starters provide many advantages when used instead of electro-mechanical contactors to control 3-phase AC induction motors. The SR22 soft starters use thyristors for controlled reduced voltage motor starting and stopping, then switch to internal contacts for efficient running at rated speed.

Features

- 5–40A @ 208–460V
- 24 VDC control voltage
- Easily and separately adjustable motor start and stop times
- Two-phase control
- Internal bypass contacts for run
- DIN rail mounting
- Two standard-size widths: 45 & 55 mm
- Six error/trip indications: AC Supply, Control Supply, Overheated, Bypass Failure, Shear Pin, Overcurrent

Advantages

Mechanical Advantages

- Smooth acceleration; reduced shock and starting stress
- Extend lifespan of mechanical drive train components
- Fluid couplings and some clutches can be eliminated

Electrical Advantages

- Reduced starting current
- More motors or larger motors can be started from lower-capacity power sources
- Allows motors to be started more frequently
- Internal mechanical contacts open and close under reduced current, increasing lifespan and reliability

Economic Advantages

- Lower overall costs for new installations
- Reduced maintenance and replacement of mechanical drive train components
- Reduced starting current reduces electrical power costs

Standards & Approvals

- UL listed* (E333109)
- *optional fans are UL recognized: E132139, E77551, E89936)
- RoHS
- CE

Optional accessories

- Cooling fan (increases # of starts/hour)

Applications

- General purpose applications where traditional across-the-line starting or wye-delta starting would typically be appropriate.



SR22 Series Compact Soft Starters *										
Model	SR22-05	SR22-07	SR22-09	SR22-12	SR22-16	SR22-22	SR22-30	SR22-36	SR22-40	
Price	<--->	<--->	<--->	<--->	<--->	<--->	<--->	<--->	<--->	
* Rated Current [class 5 starting] (A)	5	7	9	12	16	22	30	36	40	
Rated Operational Voltage	208–460 VAC (-15% +10%) @ 50–60 Hz (±2Hz); 3 phase (2 phases controlled)									
* Motor Rating	Refer to selection table. Starters must be sized according to HP AND starting class.									
Impulse Withstand Voltage	2.5 kV									
Insulation Voltage Rating	500V									
Short Circuit Current Rating	5kA Type 1 when protected by recommended semiconductor fuses									
Control Power	approx 4VA @ 24 VDC (external power supply required) (UL applications require max 4A UL listed fuse)									
Control Inputs	galvanically isolated opto-coupled inputs; require sourcing +24 VDC (control)									
Auxiliary Relay Output	250 VAC: 2.5A resistive, 0.2A inductive / 30 VDC: 3.0A resistive, 0.7A inductive									
Start Time Setting Range	1–30 seconds									
Start Voltage Setting Range	30–100%									
Stop Time Setting Range	0–30 seconds									
Start Duty	3 x full load current for 5 seconds @ standard rating									
Starts / Hour (standard)	[10 starts / hr] OR [(5 starts / hr) + (5 soft stops / hr)]									
Starts / Hour (with optional fan)	[60 starts / hr] OR [(30 starts / hr) + (30 soft stops / hr)] internally bypassed									
Ambient Operating Temperature	0–40 °C [32–104 °F] – Above 40 °C [104 °F] derate linearly by 2% of unit FLC per °C to a max derate of 40% @ 60 °C [140 °F] *** NOT UL TESTED ABOVE 40 °C ***									
Transportation & Storage Temperature	-25–60 °C [-13–140 °F]									
Humidity	max 85% non-condensing; not exceeding 50% @ 40 °C [104 °F]									
Altitude	1000m [3281 ft]; 1000–2000m [3281–6562 ft] derate 1% of unit FLC per 100–2000m [328–6562 ft]									
Environmental Rating	IP20									
Shipping Weight	400g [14 oz]					680g [24 oz]		725g [26 oz]		
Dimensions [HxWxD]	143 x 45 x 117.8 mm [5.63 x 1.77 x 4.64 in]					167.5 x 55 x 117.8 mm [6.59 x 2.17 x 4.64 in]				
Accessories										
Cooling Fan (temperature controlled) **	SR22-FAN-45					SR22-FAN-55				
Price	<--->					<--->				
Dimensions	does not add to soft starter overall dimensions					adds 10 mm [0.39 in] to soft starter H dimension				

* Refer to Selection Table for deratings by application and overload trip class.

** Cooling fans do not run continuously.



Company Info.

PLCs

Field I/O

Software

C-more & other HMI

AC Drives

AC Motors

Power Transmiss.

Steppers/ Servos

Motor Controls

Proximity Sensors

Photo Sensors

Limit Switches

Encoders

Current Sensors

Pressure Sensors

Temp. Sensors

Pushbuttons/ Lights

Process

Relays/ Timers

Comm.

Terminal Blocks & Wiring

Power

Circuit Protection

Enclosures

Tools

Appendix

Part Index

Stellar SR22 Series Compact Soft Starters

SR22 Soft Starters – O/L Trip Classes ①	
Default	5
Heavy	20
Agitator	10
Air Compressor - Equalized	5
Air Compressor - Loaded	20
Ball Mill	20
Centrifuge	n/a
Chiller	10B
Conveyor - Unloaded	5
* Conveyor - Loaded	20
Crusher	30
Escalator	10B
* Fan - Low Inertia < 85A	10
* Fan - High Inertia > 85A	30
Feeder - Screw	10
Grinder	20
Hammer Mill	20
Lathe Machine	10B
Mills - Flour, etc.	20
Mixer - Unloaded	5
Mixer - Loaded	20
Pelletizer	20
Plastic and Textile Machines	10B
Press - Flywheel	20
* Pump - Centrifugal	10B
* Pump - Positive Displacement - Unloaded	10
Rolling Mill	20
Saw - Band	10
Saw - Circular	20
Screen - Vibrating	20
Transformer, Voltage Regulator	10B
Tumbler	10
Wood Chipper	30
* Commonly required applications	

SR22 Soft Starter Selection

- ① Determine the required trip class based on the motor load and required start time.
- ② Select the applicable SR22 part number based on the required Trip Class and motor HP.
- ③ Check application duty rating. (Frequency of motor starts can be increased by installing an optional soft-starter cooling fan, SR22-FAN-xx.)

The standard range for the SR22 is Trip Class 5, which means that it is capable of withstanding three times Full Load Current for five-second starts. For applications where longer starts are required, the SR22 has four additional ratings: Class 10B, Class 10, Class 20, and Class 30. These ratings correspond to IEC thermal/electronic overload trip classes.

A separate overload protection device with a rating corresponding to the applicable trip class must be used with the SR22 soft starter.

SR22 Soft Starters – Selection Table ② *								
Motor Horsepower			Application Trip Class					
HP @ 208V	HP @ 230V	HP @ 460V	Class 5**	Class 10B	Class 10	Class 20	Class 30***	
1	1	3	SR22-05	SR22-07	SR22-09	SR22-12	SR22-16	
1.5	2	3	SR22-07	SR22-09	SR22-12	SR22-16	SR22-22	
3	3	5	SR22-12	SR22-22	SR22-30	SR22-36	SR22-40	
3	3	7.5	SR22-12	SR22-22	SR22-30	SR22-36	SR22-40	
3	5	10	SR22-16	SR22-22	SR22-30	SR22-40	SR22-40 + fan	
5	7.5	15	SR22-22	SR22-30	SR22-40	SR22-40 + fan	n/a	
7.5	10	20	SR22-30	SR22-40	SR22-40 + fan	n/a	n/a	
10	10	25	SR22-36	SR22-40 + fan	n/a	n/a	n/a	
10	15	30	SR22-40	n/a	n/a	n/a	n/a	

* A separate overload protection device with a rating corresponding to the applicable trip class must be used with the SR22.
 ** Do not use the Class 5 rating when there is a possibility of the motor starting under a heavy load.
 *** The SR22 is not suitable for very high inertia loads such as centrifuges or loaded crushers with start times > 30s.

SR22 Soft Starters – Duty Rating ③ *		
Cooling Fan	Motor Start Frequency (starts/hr)	
	Class 5	Class 10B to Class 30
without fan	10 / hr	5 / hr
with SR22-FAN-xx	60 / hr	30 / hr

* @ 40 °C [104 °F] ambient temperature

SR22 Internal Overcurrent Trip Curve

The internal overcurrent trip of the soft starter does not replace the required external overcurrent device.

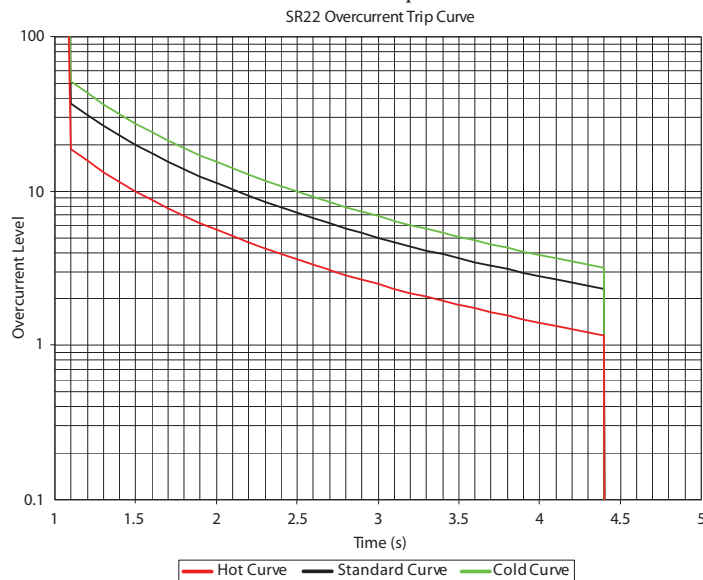

SR22 Max UL Overcurrent Protection

UL Maximum Overcurrent Protection Devices * for 5kA @ 480V Short Circuit Rating		
Soft Starter Model Number	Maximum Non-Time-Delay Trip Rating *	
	Fuse * – Class J or T (600V rated)	Circuit Breaker * (600V rated)
SR22-05	15A	N/A
SR22-07	15A	
SR22-09	30A	
SR22-12	40A	
SR22-16	50A	80A
SR22-22	80A	
SR22-30	100A	100A
SR22-36	125A	125A
SR22-40	150A	150A

* Maximum trip ratings are for non-time-delay overcurrent protection devices.
 * Motor branch circuit protection must be based on MOTOR Full Load Current, and must comply with applicable local electrical codes. The 2008 NEC section 430.52 recommends a maximum of 175% (up to 225% absolute maximum) of motor FLC for time-delay fuses. (Class CC time-delay fuses are permitted up to the non-time-delay fuse maximum rating.)

Stellar SR22 Series Compact Soft Starters



45mm Stellar Compact Soft Starter

55mm Stellar Compact Soft Starter



Cooling Fan for 45mm Soft Starters



Cooling Fan for 55mm Soft Starters

SR22 Dimensions

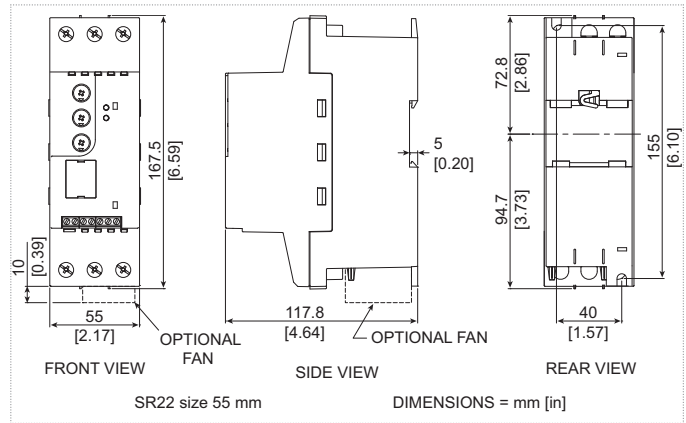
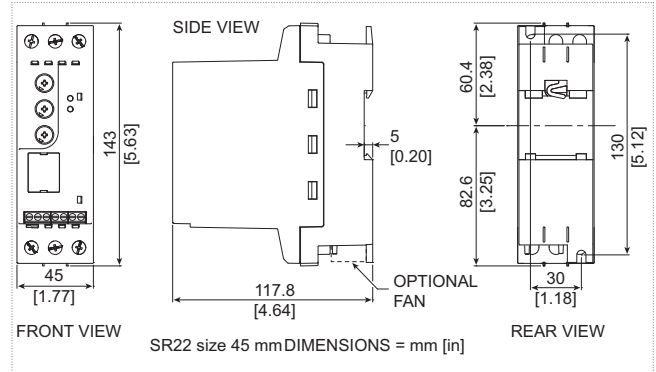

SR22 Start/Stop Timing Diagram

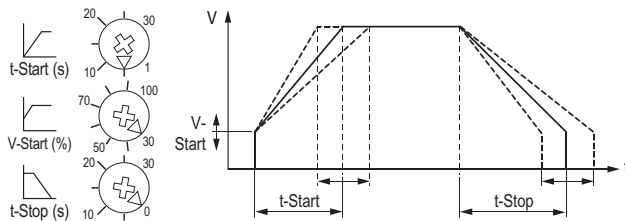

SR22 Wiring Diagram

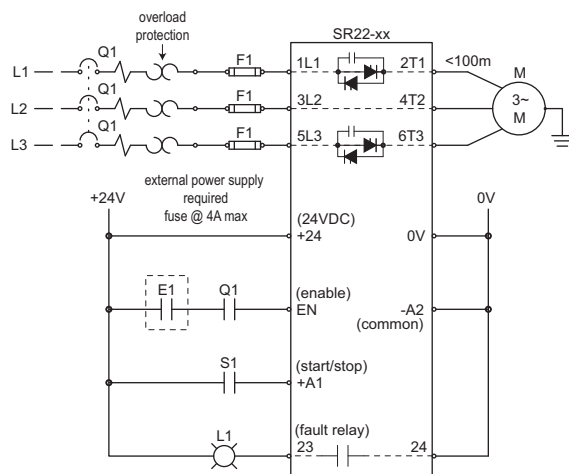

- Q1 = Cable protection
- F1 = Optional semiconductor fuse for Type 1 Coordination (in addition to Q1)
- A1-A2 = Start/Stop
- External Control Circuit Elements
- E1 = Optional switch to allow trip reset without opening main breaker Q1
- Q1 = Auxiliary contact of main breaker Q1
- S1 = Start/Stop control switch
- L1 = Indicator: ON = Ready, OFF = Fault

SR22 – PLC I/O Compatibility

SR22 – PLC & I/O Compatibility		
Product Line	Module Type	Module Numbers
CLICK	PLC	C0-00AR-D, C0-00DD2-D, C0-00DR-D, C0-02DD2-D, C0-02DR-D
	DC Output	C0-08TD2, C0-16TD2
	Relay Output	C0-04TRS, C0-08TR
DL05	PLC	D0-05AR, D0-05DR, D0-05DR-D
DL06	PLC	D0-06AR, D0-06DD2, D0-06DD2-D, D0-06DR, D0-06DR-D
DL05/DL06	DC I/O	D0-07CDR
	DC Output	D0-10TD2, D0-16TD2, D0-08TR, F0-04TRS
DL105	PLC	F1-130-DR, F1-130-DR-D
	DC I/O	D2-08CDR
DL205	DC Output	D2-08TD2, D2-16TD2-2, D2-32TD2, F2-16TD2P
	Relay Output	D2-04TRS, D2-08TR, D2-12TR, F2-08TR, F2-08TRS
	DC Output	D3-08TD2, D3-16TD2
DL305	Relay Output	D3-08TR, D3-16TR
	DC Output	D4-16TD2, D4-32TD2
DL405	Relay Output	D4-08TR, D4-16TR, F4-08TRS-1, F4-08TRS-2
	DC Output	T1K-08TD2-1, T1K-16TD2-1
Terminator I/O	Relay Output	T1K-08TR, T1K-08TRS, T1K-16TR