

Standard wiring examples

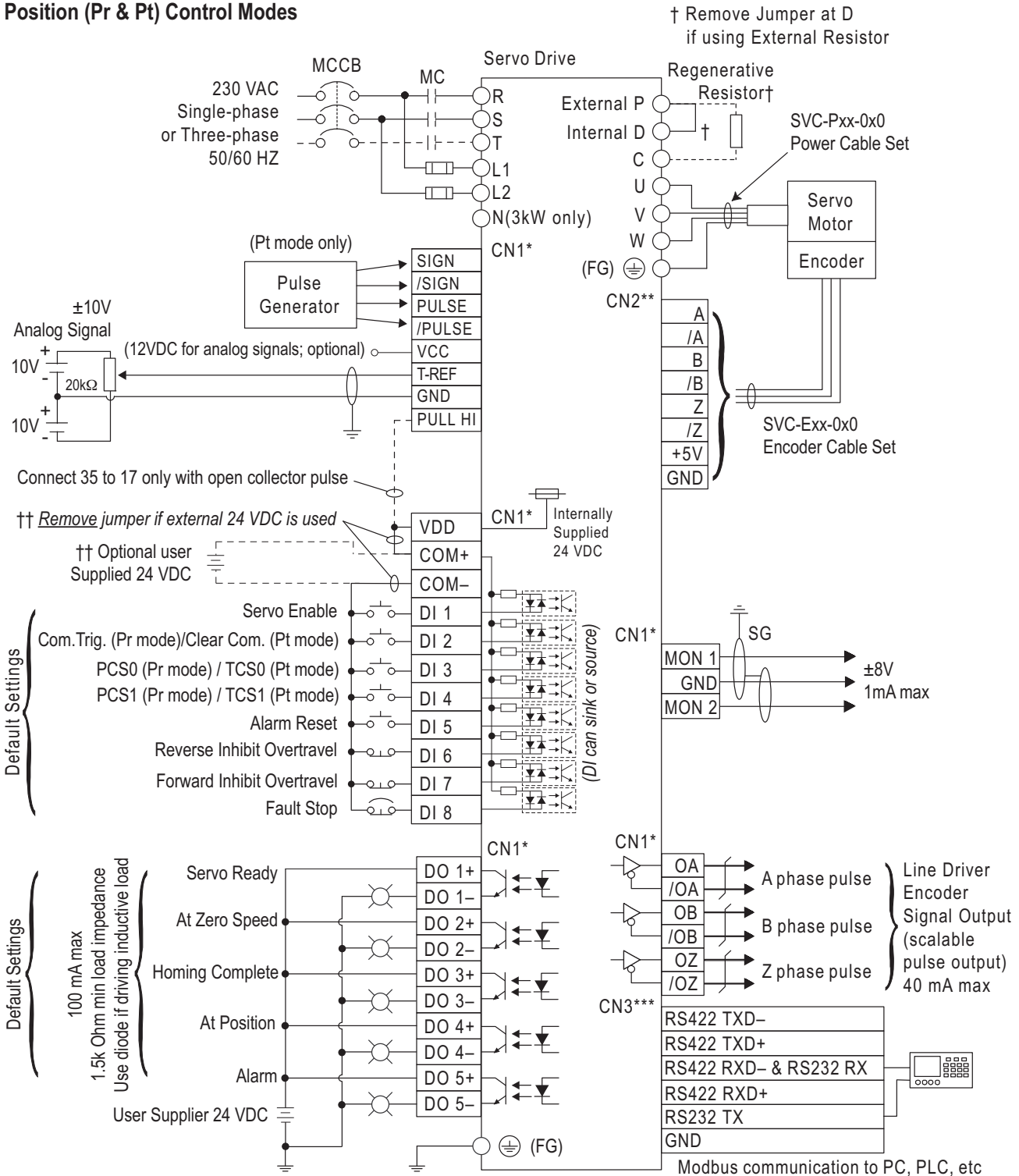

THIS WIRING DIAGRAM SHOWS BASIC WIRING ONLY, AND ADDITIONAL WIRING CONFIGURATIONS ARE POSSIBLE FOR SOME I/O. REFER TO THE "INSTALLATION AND WIRING" CHAPTER OF THE USER MANUAL FOR MORE DETAILED WIRING INFORMATION.

Position (Pr & Pt) Control Modes



* Use connection kit part #s ZL-RTB50 & ZL-SVC-CBL-50(-x) for CN1 terminal connections.

** Use cable part # SVC-Exx-0x0 for CN2 terminal connections.

*** Use cable part # SVC-MDCOM-CBL for CN3 terminal Modbus network connections.

SureServo™ AC Servo System Wiring

Standard wiring examples (continued)



THIS WIRING DIAGRAM SHOWS BASIC WIRING ONLY, AND ADDITIONAL WIRING CONFIGURATIONS ARE POSSIBLE FOR SOME I/O. REFER TO THE "INSTALLATION AND WIRING" CHAPTER OF THE USER MANUAL FOR MORE DETAILED WIRING INFORMATION.

Velocity and Torque Control Modes

† Remove Jumper at D if using External Resistor

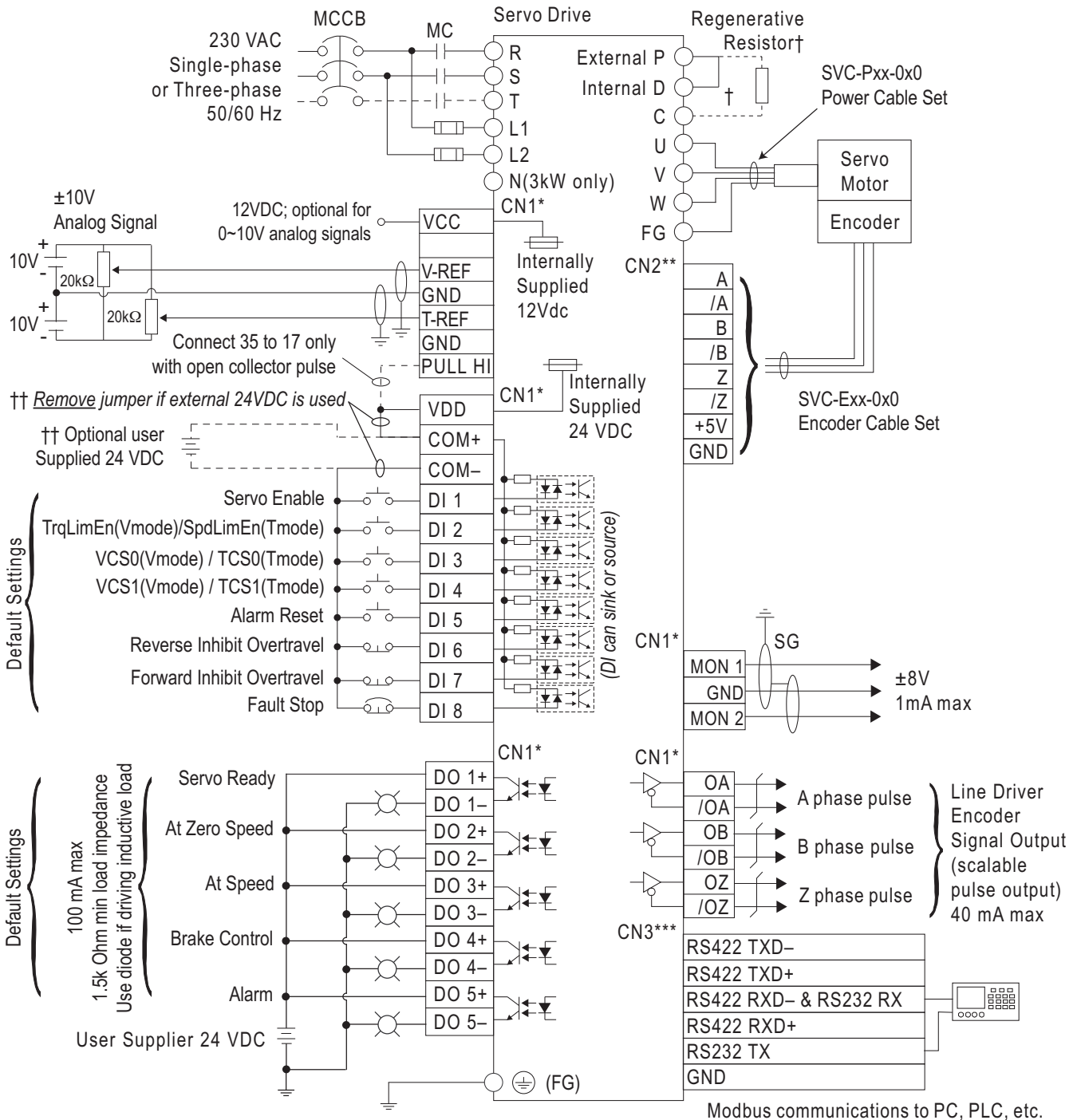

* Use connection kit part #s ZL-RTB50 & ZL-SVC-CBL-50(-x) for CN1 terminal connections.

** Use cable part # SVC-Exx-0x0 for CN2 terminal connections.

*** Use cable part # SVC-MDCOM-CBL for CN3 terminal Modbus network connections.