

SureStep[®] Stepping Systems

High-performance microstepping drives with high-torque stepping motors

SureStep stepping systems provide simple and accurate control of position and speed where open-loop control and cost are considerations. Pulses (or "step" and "direction" signals) from the DirectLOGIC family of PLCs or other indexers and motion controllers are "translated" by the microstepping drive into precise movement of the stepping motor shaft. The SureStep stepping motors use 2-phase technology with 200 full steps per revolution or 1.8° per full step. Older type stepping motor drives, which operate stepping motors in full step mode, can result in stalling or lost motion due to potential problems with low speed mechanical vibration (usually between 100 to 200 RPM). To minimize this vibration

problem, the SureStep microstepping drives use advanced microstepping technology to smooth the motor motion and stepping response. The 4035 has selectable microstep resolutions of 400 (half-step), 1,000 (each full step ÷ 5 microsteps), 2,000 (÷ 10), and 10,000 (÷ 50). The advanced drives (STP-DRV-4805, STP-DRV-80100) have software-selectable resolutions ranging from 200 (full step) to 51,200 (÷ 256) steps per revolution.

The advanced drives can operate with traditional high-speed inputs, but can also be commanded via 0 - 5V analog input and have an internal indexer that can accomplish point-to-point moves controlled via ASCII communication.

FREE configuration software!

The advanced drives include the SureStep Pro configuration tool on CD that makes setting parameters a snap!. Or download from:

<http://support.automationdirect.com/products/surestep.html>

Standards and Agency Approvals



How fast can my system go?

Maximum Potential Speed Chart				
DirectLOGIC PLC Pulse Frequency	SureStep [®] Drive Selection (Steps/Rev)			
	400 Steps/Rev	1000 Steps/Rev	2000 Steps/Rev	10,000 Steps/Rev
5,000 Hz	750 rpm	300 rpm	150 rpm	30 rpm
7,000 Hz	1050 rpm	420 rpm	210 rpm	42 rpm
10,000 Hz	1500 rpm	600 rpm	300 rpm	60 rpm
25,000 Hz	3750 rpm	1500 rpm	750 rpm	150 rpm

*Full step (200 steps/rev) will allow higher top speed. Full stepping, however, can create vibration at low speed.

$$\text{Stepping Motor RPM} = (A \div B) \times (60 \text{ seconds/minute})$$

where A = PLC output frequency (pulses per second)
B = microstepping resolution selection (steps/revolution)

	RPM =	Steps/Sec A		Steps/Rev B		Sec/Min
Example 1:	1,500 =	10,000	÷	400	X	60
<i>DL06 with 10 kHz Built-in Pulse Output</i>						
Example 2:	3,750 =	25,000	÷	400	X	60
<i>Hx-CTR10 with 25 kHz Pulse Output</i>						

4 components to make a complete system

Choose a drive, motor, motor extension cable and power supply

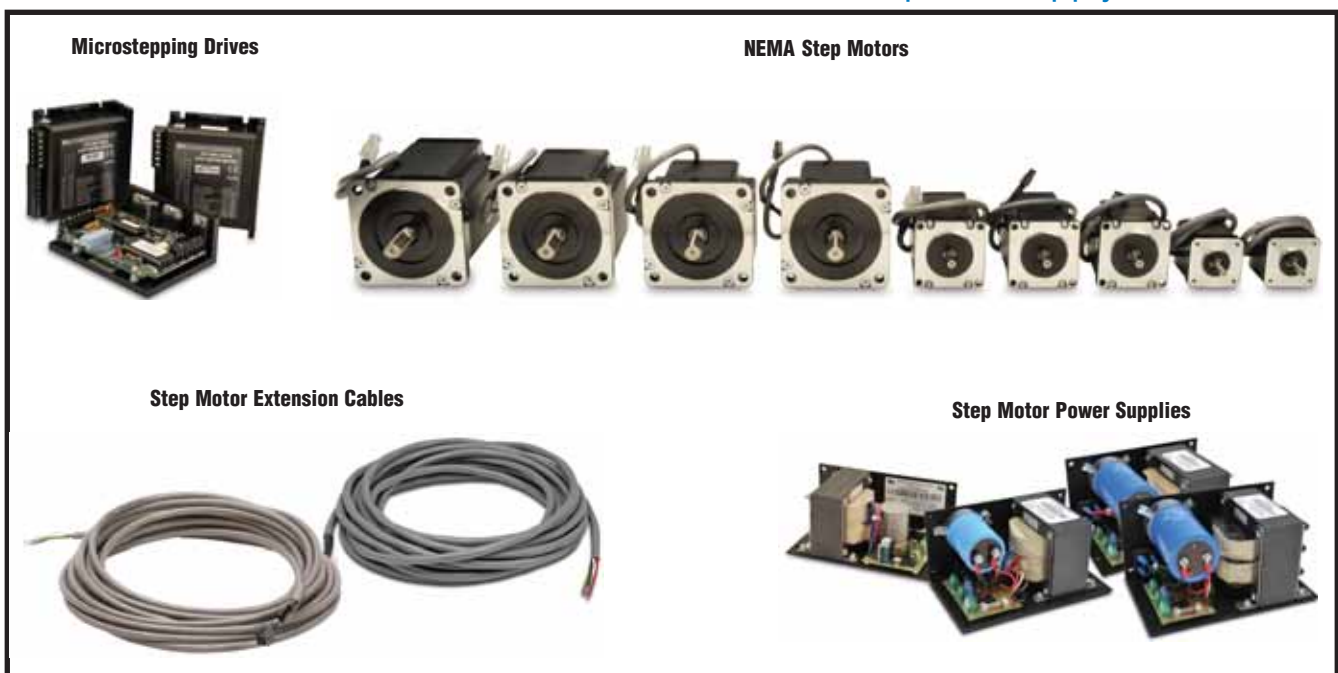

SureStepSM Stepping Systems

Stepping System : Head to Head

AutomationDirect **VS.** Competition

Hey - I can do the math! - AutomationDirect

A complete 2-axis SureStepSM Stepping System for less than just the competition's stepping drives.



SureStepSM NEMA 23 System Long Stack

Ours includes:

- Two Microstepping Drives (STP-DRV-4035)
- 2 Stepper Motors (STP-MTR-23079)
- One Power Supply (STP-PWR-3204)
- Two Extension Cables (STP-EXT-020)

\$515
Complete
2 Axis System



All prices are U.S. published prices. AutomationDirect prices are from March 2011 Price List. Parker prices are from <http://buy.compumotor.com> 3/1/11.

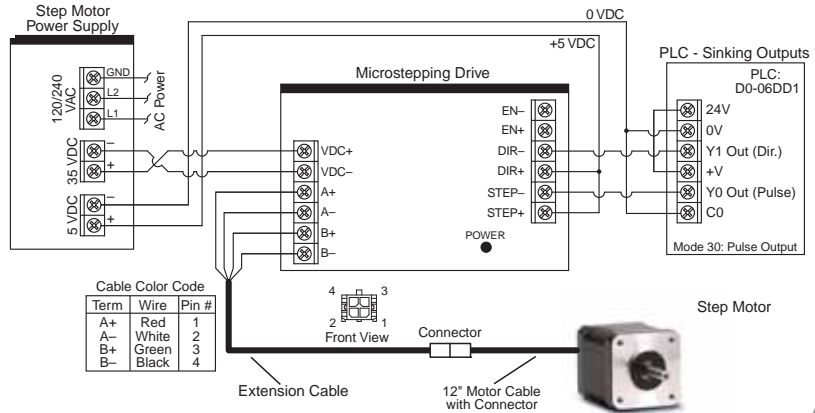

Nine high-torque motors with 1 ft. cable and 4-wire locking connector

The SureStep stepping family has nine high-torque motors to handle a wide range of automation applications such as wood-working, assembly, and test machines. Our square frame or "high torque" style stepping motors are the latest technology, resulting in the best torque to volume. We have NEMA 17, 23, and 34

mounting flanges and holding torque ranges from 61 oz-in to 1291 oz-in. 20-foot extension cables with locking connectors are a standard option to interface any of the stepping motors to the microstepping drive. The extension cables can be easily cut to length if desired.

High - torque motors

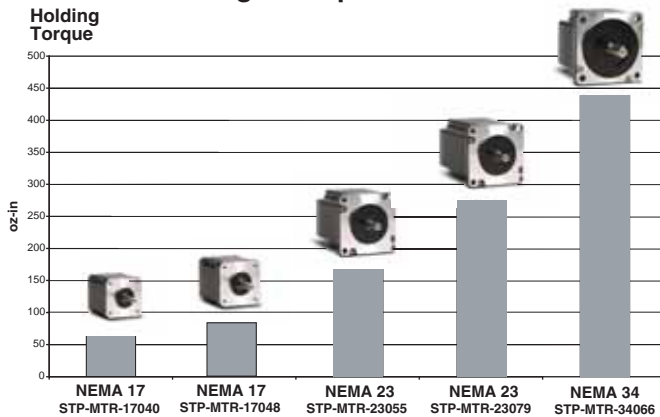

Holding Torque High - power motors

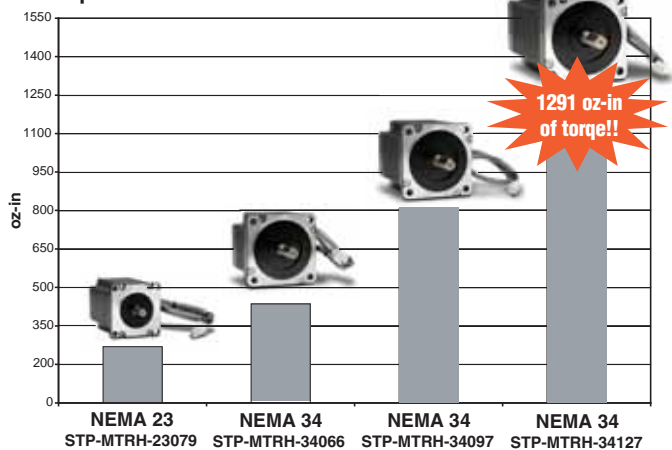

High-performance microstepping drive

- Standard high-speed pulse input (pulse and direction)
- On-board screw terminals for easy hook-up
- Optically-isolated inputs ready for +5 VDC logic from DirectLOGIC PLCs
- No software or add-on resistors required for drive configuration; 9-position dipswitch set-up
- Dipswitch used for built-in self-test, microstep resolution selection, current level selection, and optional idle current reduction.

Advanced microstepping drives

All the features of the high-performance drive, plus:

- Software configurable
- 200 - 51,200 microsteps (software selectable)
- High-speed pulse input (Quadrature, cw/ccw, pulse/direction)
- Analog velocity mode (0-5v or potentiometer)
- Internal indexer (point-to-point moves via ASCII command)

Linear power supplies

- 32V @ 4A, 48V @ 5A, 48V @ 10A, 70V @ 5A
- Input and output fuses included on power supplies
- Includes 5 VDC Logic supply for all low voltage signals



Company Information

Systems Overview

Programmable Controllers

Field I/O

Software

C-more & other HMI

Drives

Soft Starters

Motors & Gearbox

Steppers/ Servos

Motor Controls

Proximity Sensors

Photo Sensors

Limit Switches

Encoders

Current Sensors

Pressure Sensors

Temperature Sensors

Pushbuttons/ Lights

Process

Relays/ Timers

Comm.

Terminal Blocks & Wiring

Power

Circuit Protection

Enclosures

Tools

Pneumatics

Safety

Appendix

Product Index

Part #

Index

SureStep® Choose your SureStep System

1. Choose a motor

Determine the torque and speed required by your application. Then look at the motor speed-torque curves in this chapter's Technical Info section. Choose a motor that can run your application with plenty of speed and torque reserve (most stepper systems should have a 100% safety margin for torque).

NEMA 17, 23 and 34 mounting flanges

Holding torque ranges from 61 to 1291 oz-in



Nine bipolar step motors to cover a wide range of applications

1-ft cable (4-wire) with locking connector on the end

Square frame style produces high torque and achieves best torque to volume ratio

2. Choose a motor extension cable

Our 20-ft motor extension cables have a locking connector that mates up to the motor cable. The extension cables allow you to quickly connect the motor to the drive without having to splice wires or cut any cables. If you chose an STP-MTR-xxxx motor, select an STP-EXT-020 cable. If you chose an STP-MTRH-xxxx motor, select an STP-EXTH-020 cable. (The "H" motors and cable can handle higher motor current)

20-foot extension cable with locking connector; for use with all SureStep motors

STP-EXT-020
STP-EXTH-020



3. Choose a drive

This chart is a quick selection guide. For a full list of features, check out the Technical Info later in this chapter.

What you need	STP-DRV-4035	STP-DRV-4850	STP-DRV-80100
32V Speed-Torque Curve (from Step 1)	✓	✓	✓
48V Speed-Torque Curve (from Step 1)		✓	✓
70V Speed-Torque Curve (from Step 1)			✓
Pulse & Direction Input	✓	✓	✓
More than 3.5A/motor phase		✓	✓
More than 5A/motor phase ("H" motors)			✓
Internal Indexing (Drive can move from Point A to Point B with a serial communication command)		✓	✓
Analog Velocity Input		✓	✓

Optional idle current reduction

Adjustable microstep resolutions

0.1 to 10 amps (depending on drive model)

Optically isolated step, direction and enable inputs

Screw terminal connections

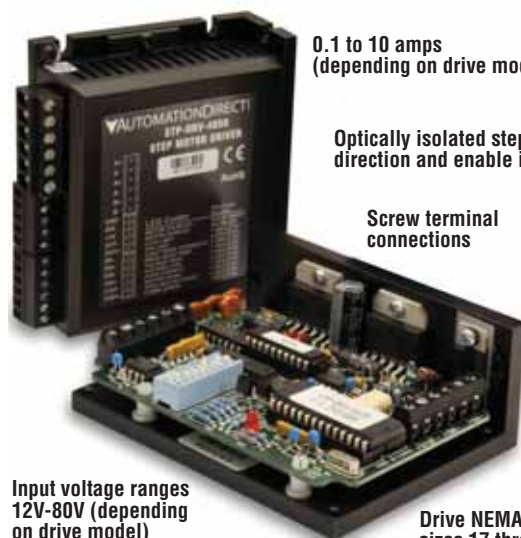

Input voltage ranges 12V-80V (depending on drive model)

Drive NEMA sizes 17 through 34 step motors

...in 4 easy steps

4. Choose a power supply

Since all SureStep motors can operate at 32V, 48V, and 70V, the selection of a power supply is dependent on the selected speed-torque curve of the motor and on the selection of drive. Choose a power supply that matches the desired speed-torque curve

and stays within the voltage limit of the selected drive. Each power supply has incoming AC and outgoing DC fusing. There is also an electronically overload protected 5V supply for all your logic needs.

Permissible Drive/Power Supply Combinations

Power Supply	STP-PWR-3204	STP-PWR-4805	STP-PWR-4810	STP-PWR-7005
Drive				
STP-DRV-4035	✓			
STP-DRV-4850	✓	✓	✓	
STP-DRV-80100	✓	✓	✓	✓

For systems that use multiple drives and only one power supply, please read our SureStep Manual (under "Product Documentation") to properly size multiple systems.

120 or 240 VAC, 50/60 Hz power input (switch selectable)

Screw terminal AC input and DC output connections

32V, 48V and 70V linear supplies

Power ON LEDs

Unregulated linear supplies perfect for stepper systems

Input and output fusing included



5 VDC \pm 5% at 500 mA regulated logic power

2-Phase Microstepping Drive



Motor Extension Cable

Typical System

NEMA Step Motor

Step Motor Power Supply

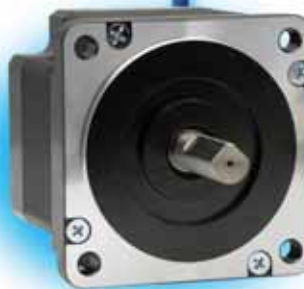

SureStep® Stepping Systems

System Overview

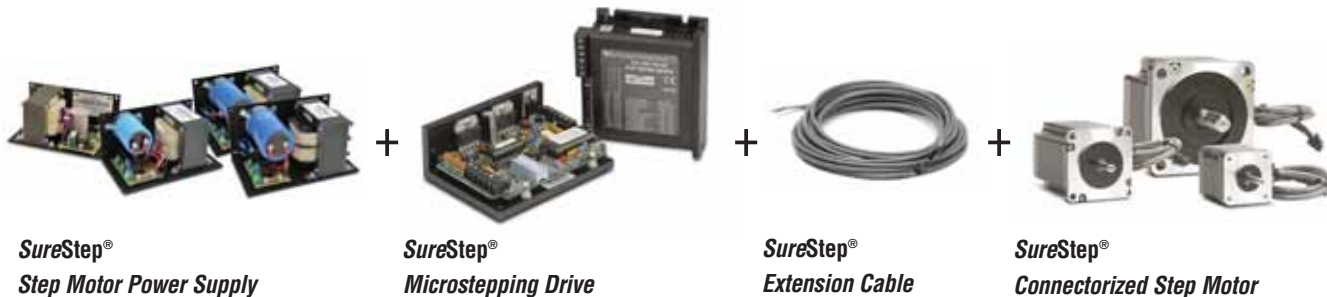

The SureStep® stepping system series includes:

- Four step motor power supplies
- One DIP-switch configurable microstepping drive
- Two software configurable advanced microstepping drives
- Two motor extension cables
- Nine step motors (NEMA 17, 23, 34 frame sizes)

Standard stepper drive features

- Max 3.5A, 40V
- DIP switch configurable
- Selectable microstepping: x2, x5, x10, x50 steps/revolution
- Self test feature
- Idle current reduction

Advanced stepper drive features

- Max 5A, 48V and max 10A, 80V models available
- Software configurable
- Programmable microsteps
- Internal indexer (via ASCII commands)
- Self test feature
- Idle current reduction
- Anti-resonance
- Torque ripple smoothing
- Step, analog, & serial communication inputs
- Serial communications allow point-to-point positioning

Motor features

- High torque, 2-phase, bipolar, 1.8° per step, 4-lead
- (2) NEMA 17 motors
- (3) NEMA 23 motors
- (4) NEMA 34 motors

Power supply features

- Linear, unregulated DC power supplies
- 120/240 VAC selectable input
- 32V, 48V, 70V DC output models available
- All models have additional 5VDC, 500 mA regulated logic supply
- Fusing included for both incoming AC and outgoing DC
- 5V supply has electronic overload protection

SureStep Part Number Explanation

STP- MTR H - 23079

Component Capacity

For DRV: 2-digit max nominal voltage followed by max current with 1 implied decimal place
 4035: 40V, 3.5A
 4850: 48V, 5.0A
 80100: 80V, 10.0A
 For EXT(H): cable length in feet
 For MTR(H): 2-digit NEMA frame size followed by approximate length in mm
 For PWR: 2-digit output voltage followed by output current

Component Type

DRV: stepper drive
 EXT: motor extension cable
 EXTH: high-power motor extension cable
 MTR: stepper motor
 MTRH: high-power stepper motor
 PWR: power supply

SureStep Series Designation: STP

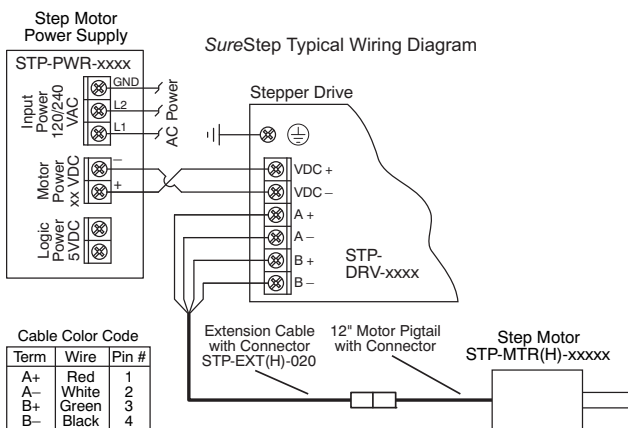

SureStep® System Recommended Component Compatibility			
Drives (1)	Power Supplies (1)	Motors & Extension Cables (2,3)	
STP-DRV-4035	-	-	STP-MTR-xxxxx & STP-EXT-020
STP-DRV-4850	-	STP-PWR-4805	
STP-DRV-80100	STP-PWR-7005	STP-PWR-3204	STP-MTRH-xxxxx & STP-EXTH-020
		STP-PWR-4810	

1) Caution: Do not use a power supply that exceeds the drive input voltage range. Using a lower voltage power supply with a higher voltage drive is acceptable, but will not provide full system performance.

2) MTR motors have connectors compatible with the EXT extension cables.

3) MTRH motors have connectors compatible with the EXTH extension cables.

SureStep[®] Stepping System Drives

Microstepping Drives

SureStep[®] Series Specifications – Microstepping Drives				
Microstepping Drive	STP-DRV-4035	STP-DRV-4850	STP-DRV-80100	
Price	<--->	<--->	<--->	
Drive Type	Microstepping drive with pulse input	Advanced microstepping drive with pulse or analog input, serial communication (serial communication allows indexing capability)		
Output Current	selectable from 0.4 to 3.5 A/phase (maximum output power is 140 W)	0.1-5.0 A/phase (in 0.01A increments)	0.1-10.0 A/phase (in 0.01A increments)	
Input Voltage (external p/s required)	12-42 VDC (including ripple voltage)	24-48 VDC (nominal) (range: 18-53 VDC)	24-80 VDC (nominal) (range: 18-88 VDC)	
Configuration Method	dip switches	SureStep Pro software (included)		
Amplifier Type	MOSFET, dual H-bridge, bipolar chopper	MOSFET, dual H-bridge, 4-quadrant		
Current Control	3-state PWM 20 kHz	4-state PWM @ 20 kHz		
Protection	n/a	over-voltage, under-voltage, over-temperature, external output faults (phase-to-phase & phase-to-ground), inter-amplifier shorts		
Recommended Input Fusing	Fuse: 4A fast acting; ADC # ACG4 Fuse Holder: ADC # DN-F6L110	Fuse: 4A 3AG delay (ADC #MDL4) Fuse Holder: ADC #DN-F6L110	Fuse: 6.25A 3AG delay (ADC #MDL6-25) Fuse Holder: ADC #DN-F6L110	
Input Signals	Input Circuit	Opto-coupler input with 440Ω resistance (5 to 15 mA input current); Logic Low is input 0.8 VDC or less; Logic High is input 4 VDC or higher.		
	Step/Pulse	Motor steps on falling edge of pulse and minimum pulse width is 0.5 microseconds (1MHz)		
	Direction	Needs to change at least 2 microseconds before a step pulse is sent		
	Enable	Logic 1 will disable current to the motor (current is enabled with no hook-up or logic 0)		
	Analog	n/a		
Output Signal	n/a	optically isolated, 24V, 10mA max; FUNCTIONS: fault, motion, tach		
Communication Interface	n/a	RS-232; RJ11 (6P4C) receptacle		
Non-volatile Memory Storage	n/a	Configurations are saved in FLASH memory on-board the DSP.		
Features	Idle Current Reduction	0% or 50% reduction (idle current setting is active if motor is at rest for 1 second or more)		
	Microstep Resolution	400 (200x2), 1,000 (200x5), 2,000 (200x10), or 10,000 (200x50) steps/rev		
	Modes of Operation	step & direction		
	Phase Current Setting	0.4 to 3.5 A/phase with 32 selectable levels	0.1-5.0 A/phase (in 0.01A increments)	0.1-10.0 A/phase (in 0.01A increments)
	Self Test	uses half-step to rotate 1/2 revolution in each direction at 100 steps/second		
	Additional Features	n/a	Anti-resonance (Electronic Damping) Auto setup Microstep emulation Torque ripple smoothing (allows for fine adjustment of phase in the range 0.25 to 1.5 rps) Waveform (command signal) smoothing	
Connectors	Screw terminal blocks with AWG 18 maximum wire size		Communication: RJ11 (6P4C); Other: removable screw terminal blocks	
Maximum Humidity	90% non-condensing			
Storage Temperature	-20 to 80 °C [-4 to 176 °F]			
Operating Temperature	0 to 55 °C [32 to 131 °F] recommended; 70 °C [158 °F] maximum		0-55 °C [32-151 °F]; (mount to suitable heat sink)	
Drive Cooling Method	natural convection (mount drive to metal surface to dissipate heat)		natural convection (mount to suitable heat sink)	
Mounting	(4) #4 screws to mount on wide side; (2) #4 screws to mount on narrow side		#6 mounting screws (mount to suitable heat sink)	
Dimensions	3.0 x 4.0 x 1.5 inches [76.2 x 101.6 x 38.1 mm]		3.0 x 3.65 x 1.125 inches [76.2 x 92.7 x 28.6 mm]	
Weight	9.3 oz. [264 g]		8 oz [227g] (approximate)	
Agency Approvals	CE (complies with EN55011A & EN50082-1 (1992)), RoHS		CE, RoHS	

Wiring Solutions using the ZIPLink Wiring System

ZIPLinks eliminate the normally tedious process of wiring between devices by utilizing prewired cables and DIN rail mount connector modules. It's as simple as plugging in a cable connector at either end or terminating wires at only one end. Prewired cables keep installation clean and efficient, using half the space at a fraction of the cost of standard terminal blocks. There are several wiring solutions available when using the ZIPLink System ranging from

PLC I/O-to-ZIPLink Connector Modules that are ready for field termination, options for connecting to third party devices, GS, DuraPulse and SureServo Drives, and specialty relay, transorb and communications modules. Pre-printed I/O-specific adhesive label strips for quick marking of ZIPLink modules are provided with ZIPLink cables. See the following solutions to help determine the best ZIPLink system for your application.

Solution 1: DirectLOGIC, CLICK and Productivity3000 I/O Modules to ZIPLink Connector Modules

When looking for quick and easy I/O-to-field termination, a ZIPLink connector module used in conjunction with a prewired ZIPLink cable, consisting of an I/O terminal block at one end and a multi-pin connector at the other end, is the best solution.

Using the PLC I/O Modules to ZIPLink Connector Modules selector tables located in this section,

1. Locate your I/O module/PLC.
2. Select a ZIPLink Module.
3. Select a corresponding ZIPLink Cable.



Solution 2: DirectLOGIC, CLICK and Productivity3000 I/O Modules to 3rd Party Devices

When wanting to connect I/O to another device within close proximity of the I/O modules, no extra terminal blocks are necessary when using the ZIPLink Pigtail Cables. ZIPLink Pigtail Cables are prewired to an I/O terminal block with color-coded pigtail with soldered-tip wires on the other end.

Using the I/O Modules to 3rd Party Devices selector tables located in this section,

1. Locate your PLC I/O module.
2. Select a ZIPLink Pigtail Cable that is compatible with your 3rd party device.



Solution 3: GS Series and DuraPulse Drives Communication Cables

Need to communicate via Modbus RTU to a drive or a network of drives?

ZIPLink cables are available in a wide range of configurations for connecting to PLCs and SureServo, SureStep, Stellar Soft Starter and AC drives. Add a ZIPLink communications module to quickly and easily set up a multi-device network.

Using the Drives Communication selector tables located in this section,

1. Locate your Drive and type of communications.
2. Select a ZIPLink cable and other associated hardware.



Drives

Soft Starters

Motors & Gearbox

Steppers/ Servos

Motor Controls

Proximity Sensors

Photo Sensors

Limit Switches

Encoders

Current Sensors

Pressure Sensors

Temperature Sensors

Pushbuttons/ Lights

Process

Relays/ Timers

Comm.

Terminal Blocks & Wiring

Power

Circuit Protection

Enclosures

Tools

Pneumatics

Safety

Appendix

Product Index

Part # Index

Solution 4: Serial Communications Cables

ZIPLink offers communications cables for use with *Direct*LOGIC, CLICK, and Productivity3000 CPUs, that can also be used with other communications devices. Connections include a 6-pin RJ12 or 9-pin, 15-pin and 25-pin D-sub connectors which can be used in conjunction with the RJ12 or D-Sub Feedthrough modules.

Using the **Serial Communications Cables** selector table located in this section,

1. Locate your connector type
2. Select a cable.



Solution 5: Specialty ZIPLink Modules

For additional application solutions, ZIPLink modules are available in a variety of configurations including stand-alone relays, 24VDC and 120VAC transorb modules, D-sub and RJ12 feedthrough modules, communication port adapter and distribution modules, and SureServo 50-pin I/O interface connection.

Using the **ZIPLink Specialty Modules** selector table located in this section,

1. Locate the type of application.
2. Select a ZIPLink module.



Solution 6: ZIPLink Connector Modules to 3rd Party Devices

If you need a way to connect your device to terminal blocks without all that wiring time, then our pigtail cables with color-coded soldered-tip wires are a good solution. Used in conjunction with any compatible ZIPLink Connector Modules, a pigtail cable keeps wiring clean and easy and reduces troubleshooting time.

Using the **Universal Connector Modules and Pigtail Cables** table located in this section,

1. Select module type.
2. Select the number of pins.
3. Select cable.



Drive / Motor Controller (GS/DuraPulse/SureServo/SureStep/Stellar) ZIPLink Selector										
Drive / Motor Controller		Communications			ZIPLink Cable					
Controller	Comm Port Type	Network/Protocol	Connects to	Comm Port Type	Cable (2 meter length)	Cable Connectors	Other Hardware Required			
GS1	RJ12	RS-485 Modbus RTU	DL06 PLCs	Port 2 (HD15)	GS-485HD15-CBL-2	RJ12 to HD15	—			
			D2-260 CPU				—			
			GS-EDRV100	RJ12		GS-EDRV-CBL-2	RJ12 to RJ12	—		
			ZL-CDM-RJ12Xxx*	RJ12		GS-485RJ12-CBL-2		—		
FA-ISOCOCON	5-pin Connector	GS-ISOCOCON-CBL-2	RJ12 to 5-pin plug	—						
GS2	RJ12	RS-232 Modbus RTU	CLICK PLCs	Port 2 (RJ12)	GS-RJ12-CBL-2	RJ12 to RJ12	—			
			DL05 PLCs				—			
			DL06 PLCs				—			
			D2-250-1 CPU	Port 2 (HD15)			FA-15HD			
			D2-260 CPU							
			D4-450 CPU					Port 3 (25-pin)	FA-CABKIT	
		P3-550 CPU	Port 2 (RJ12)	—						
		RS-485 Modbus RTU	DL06 PLCs	Port 2 (HD15)		GS-485HD15-CBL-2		RJ12 to HD15	—	
			D2-260 CPU						—	
			GS-EDRV100				RJ12		GS-EDRV-CBL-2	RJ12 to RJ12
			ZL-CDM-RJ12Xxx*	RJ12			GS-485RJ12-CBL-2	—		
			FA-ISOCOCON	5-pin Connector			GS-ISOCOCON-CBL-2	RJ12 to 5-pin plug	—	
DuraPulse (GS3)	RJ12		RS-485 Modbus RTU	DL06 PLCs	Port 2 (HD15)		GS-485HD15-CBL-2	RJ12 to HD15	—	
		D2-260 CPU		—						
		GS-EDRV100		RJ12	GS-EDRV-CBL-2	RJ12 to RJ12		—		
		ZL-CDM-RJ12Xxx*		RJ12	GS-485RJ12-CBL-2			—		
		FA-ISOCOCON		5-pin Connector	GS-ISOCOCON-CBL-2			RJ12 to 5-pin plug	—	
SureServo	IEEE1394 (CN3)	RS-232 Modbus RTU	CLICK PLCs	Port 2 (RJ12)	SVC-232RJ12-CBL-2	6-pin IEEE to RJ12	—			
			DL05 PLCs				—			
			DL06 PLCs				—			
			D2-250-1 CPU	Port 2 (HD15)			FA-15HD			
			D2-260 CPU							
			D4-450 CPU					Port 3 (25-pin)	FA-CABKIT	
		P3-550 CPU	Port 2 (RJ12)	—						
		RS-485 Modbus RTU	DL06 PLCs	Port 2 (HD15)		SVC-485HD15-CBL-2		6-pin IEEE to HD15	—	
			D2-260 CPU						—	
			ZL-CDM-RJ12Xxx*				RJ12		SVC-485RJ12-CBL-2	6-pin IEEE to RJ12
			USB-485M	RJ45			SVC-485CFG-CBL-2	6-pin IEEE to RJ45	—	
			Stellar (Soft Starter) SR44 Series	RJ45**			RS-485 Modbus RTU	DL06 PLCs	Port 2 (HD15)	
D2-250-1 CPU										
D2-260 CPU	RJ12	SR44-485RJ45-CBL-2			RJ45 to RJ12					
ZL-CDM-RJ12Xxx*										
SureStep	RJ12	RS-232 ASCII	DL06 PLCs	Port 2 (HD15)	STP-232HD15-CBL-2	HD15-pin to RJ12	—			
			D2-250-1 CPU				—			
			D2-260 CPU (Port2)				—			
			DL05 PLCs	RJ12		STP-232RJ12-CBL-2	RJ12 to RJ12	—		
			CLICK PLCs					—		

* When using the ZL-CDM-RJ12Xxx ZIPLink Communication Distribution Module, replace the lowercase xx with the number of RJ12 ports, i.e.4 for four ports or10 for ten ports. (ex: ZL-CDM-RJ12X4 or ZL-CDM-RJ12X10)

** The SR44-RS485 Communications Adapter must be installed for RS-485 communications with the Stellar soft starters.