

UL489 or UL1077?

What are your Circuit Protection Requirements?

An understanding of circuit types and circuit protection products is critical to ensure their proper application.
See NEC Sections 100, 430 and 409 for definitions.

The proper sizing of an overcurrent protection device is the responsibility of the customer and should be determined using the application standards of the NEC (National Electric Code), CEC (Canadian Electrical Code) or other applicable standards. Per fine print note of 2008 NEC Section 100 "A current in excess of rating may be accommodated by certain equipment and conductors for a given set of conditions. Therefore, the rules for overcurrent protection are specific for particular situations."

UL489 Branch Protection



UL1077 Supplementary Protection



What You Need to Know and Look For In Specifications

Certifications – Standards – Acceptance

UL489 Branch Protection

- UL489 Listed or Recognized
- CSA C22.2 No. 5
- International ratings available depending on breaker type

UL1077 Supplementary Protection

- UL Recognized under UL1077
- CSA 22.2 No. 285
- IEC 60947-2 or IEC 898

Function

- Opens automatically on Overload and Short Circuit when properly applied within its ratings
- Protects wire and cable against Overload and Short Circuit
- Opens automatically on Overload and Short Circuit
- Provides additional equipment protection where branch circuit protection is already provided or not required
- Not suitable for the protection of branch circuit conductors

Applications

- Branch circuit protection in control panels, panelboards, switchboards and motor control centers
- Motor overload and motor short circuit protection (UL489 Recognized motor circuit protectors) for control panels and motor control centers
- Used within appliances or other electrical equipment such as control circuits, control power transformers, relays, PLC I/O points and lighting circuits
- Ideal replacement for fuses that are applied as supplementary protection

Features

- Bolted down or DIN-rail mounted
- External handle mechanisms available
- Field mounted accessories
- Stand alone branch circuit protection
- Various levels of protection (curve type)
- High voltage and interruption levels (up to 100 kAIC @ 480V)
- DIN-Rail mounted
- Field mounted accessories
- Current limiting
- Various levels of protection (curve type)
- 10 kAIC @ 240 VAC
- 6 kAIC @ 277 VAC and 5 kAIC @ 480 VAC
- 10 kAIC @ 65 VDC

kAIC = thousands of Amps interrupt capacity

Summary

A Supplementary Protector can't Be used for Branch Circuit Protection.
Understanding the difference between Branch Circuit Protection and Supplementary Protection helps to ensure their proper use.

EAT•N WMZT Miniature Circuit Breakers



Overview

Eaton WMZT miniature circuit breakers offer optimum and efficient protection for branch and control circuits up to 40 amps. The WMZT series is available with C or D trip characteristics in accordance with UL489. These circuit breakers are current limiting, which means they interrupt fault currents within one half cycle of the fault. The WMZT series is DIN-rail mountable and can be used in branch circuit applications.

Listings

- UL Listed and Recognized under UL 489 Category DIVO File E7819 Category DKSY2 File E7819 Category DIHS E64983
- CSA 22.2, No. 5 File 245545
- CE LVD 2006/95/EC
- IEC/EN 60947-2



Features and Benefits

- Complete range of UL489 listed DIN rail mounted miniature circuit breakers up to 40 ampere current rating
- Single pole, two-pole and three pole models
- Current limiting design provides fast short circuit interruption that reduces the let-through energy, which can damage the circuit
- Suitable for branch circuit device protection
- Thermal-magnetic overcurrent protection — two levels of short circuit protection, categorized by C and D curves

C curve magnetic trip point:

5 to 10 times the rated current, typically used for small transformers, pilot devices, etc.

D curve magnetic trip point:

10 to 20 times the rated current, typically used for transformers or loads with very high inductive loads.

- Trip-free design — breaker cannot be defeated by holding the handle in the “ON” position
- Captive screws cannot be lost
- SWD (switching duty) rated circuit breaker — suitable for switching fluorescent lighting loads ($I_n \leq 20A$)
- Fulfills UL 489, CSA C22.2 No.5 and also IEC 60947-2 Standard
- Can also be used in applications for which UL 1077 or CSA C22.2 No.235 are also allowed
- Field installable shunt trip and auxiliary switch subsequent mounting (See Allowable Combinations page)
- Module width of only 17.7 mm (per pole)
- Contact position indicator (red / green)
- 35 mm DIN-rail mountable, utilizing spring clip
- Suitable for reverse feed applications

Applications

Feeder and Branch Circuit Protection

- Convenience receptacle circuits (internal / external)
- Motor control circuits
- Load circuits leaving the equipment (external)
- HACR Equipment (Heating Air Conditioning, Refrigeration)
- PLC I/O points
- Computers
- Power supplies
- Control instrumentation
- Relays
- UPS
- Power conditioners

EATON WMZT Miniature Circuit Breakers

Tripping Characteristics

Eaton WMZT miniature circuit breakers are available with “C” and “D” tripping characteristics.

Type C trip curve: 5 to 10 I_n

C-curve devices are suitable for applications where medium levels of inrush current are expected. Applications include small transformers, lighting, pilot devices, control circuits and coils. C-curve devices provide a medium magnetic trip point.

Type D trip curve: 10 to 20 I_n

D-curve devices are suitable for applications where high levels of inrush current are expected. The high magnetic trip point prevents nuisance tripping in high inductive applications such as motors, transformers and power supplies.

Eaton WMZT devices are current limiting, which means they interrupt fault currents within one half cycle of the fault. Current limiting devices offer superior protection by reducing peak let-through current and energy.

Labeling

The front of each Eaton WMZT miniature circuit breaker is labeled for positive identification.

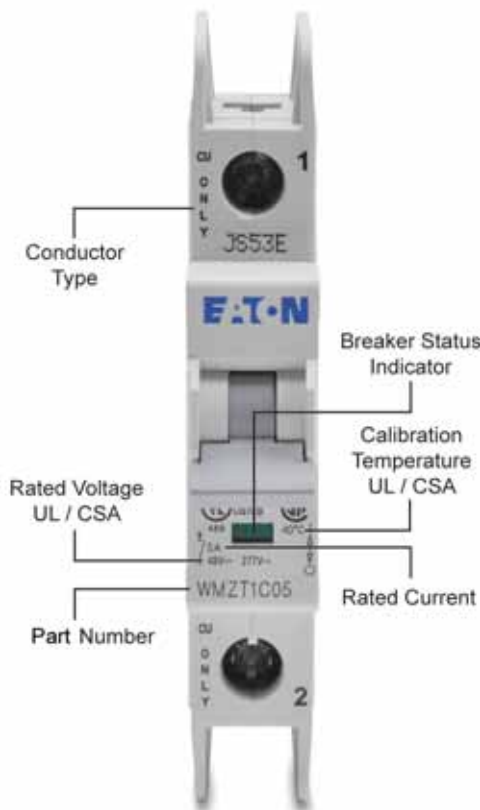
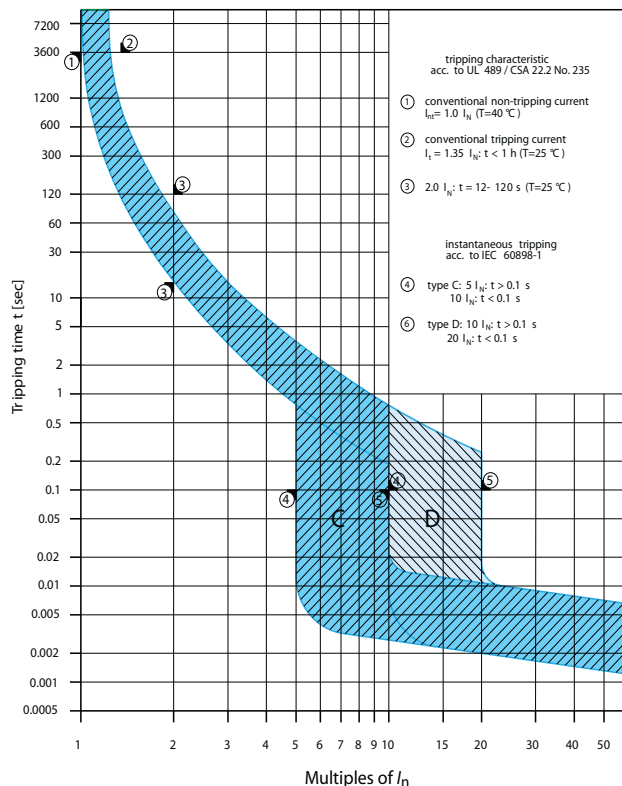

EAT•N WMZT Series Selection Guide



Single-Pole

WMZT - Single-Pole Selection Guide				
Ampere Rating	C Curve Part Number	Price	D Curve Part Number	Price
0.5	WMZT1CX0		WMZT1DX0	
1	WMZT1C01		WMZT1D01	
1.5	WMZT1CX1		WMZT1DX1	
2	WMZT1C02		WMZT1D02	
3	WMZT1C03		WMZT1D03	
4	WMZT1C04		WMZT1D04	
5	WMZT1C05		WMZT1D05	
6	WMZT1C06		WMZT1D06	
7	WMZT1C07		WMZT1D07	
8	WMZT1C08	<--->	WMZT1D08	<--->
10	WMZT1C10		WMZT1D10	
13	WMZT1C13		WMZT1D13	
15	WMZT1C15		WMZT1D15	
16	WMZT1C16		WMZT1D16	
20	WMZT1C20		WMZT1D20	
25	WMZT1C25		WMZT1D25	
*30	WMZT1C30		WMZT1D30	
*32	WMZT1C32		WMZT1D32	
*40	WMZT1C40		WMZT1D40	

* Rated 240 VAC



Two-Pole

WMZT - Two-Pole Selection Guide				
Ampere Rating	C Curve Part Number	Price	D Curve Part Number	Price
0.5	WMZT2CX0		WMZT2DX0	
1	WMZT2C01		WMZT2D01	
1.5	WMZT2CX1		WMZT2DX1	
2	WMZT2C02		WMZT2D02	
3	WMZT2C03		WMZT2D03	
4	WMZT2C04		WMZT2D04	
5	WMZT2C05		WMZT2D05	
6	WMZT2C06		WMZT2D06	
7	WMZT2C07		WMZT2D07	
8	WMZT2C08	<--->	WMZT2D08	<--->
10	WMZT2C10		WMZT2D10	
13	WMZT2C13		WMZT2D13	
15	WMZT2C15		WMZT2D15	
16	WMZT2C16		WMZT2D16	
20	WMZT2C20		WMZT2D20	
25	WMZT2C25		WMZT2D25	
*30	WMZT2C30		WMZT2D30	
*32	WMZT2C32		WMZT2D32	
*40	WMZT2C40		WMZT2D40	

* Rated 240 VAC

Note: Eaton parts available for sale to North America locations only.

EATON WMZT Series Selection Guide



- Company Information
- Systems Overview
- Programmable Controllers
- Field I/O
- Software
- C-more & other HMI
- Drives
- Soft Starters
- Motors & Gearbox
- Steppers/ Servos
- Motor Controls
- Proximity Sensors
- Photo Sensors
- Limit Switches
- Encoders
- Current Sensors
- Pressure Sensors
- Temperature Sensors
- Pushbuttons/ Lights
- Process
- Relays/ Timers
- Comm.
- Terminal Blocks & Wiring
- Power
- Circuit Protection
- Enclosures
- Tools
- Pneumatics
- Safety
- Appendix
- Product Index
- Part # Index

WMZT - Three-Pole Selection Guide				
Ampere Rating	C Curve Part Number	Price	D Curve Part Number	Price
0.5	WMZT3CX0		WMZT3DX0	
1	WMZT3C01		WMZT3D01	
1.5	WMZT3CX1		WMZT3DX1	
2	WMZT3C02		WMZT3D02	
3	WMZT3C03		WMZT3D03	
4	WMZT3C04		WMZT3D04	
5	WMZT3C05		WMZT3D05	
6	WMZT3C06		WMZT3D06	
7	WMZT3C07		WMZT3D07	
8	WMZT3C08	<--->	WMZT3D08	<--->
10	WMZT3C10		WMZT3D10	
13	WMZT3C13		WMZT3D13	
15	WMZT3C15		WMZT3D15	
16	WMZT3C16		WMZT3D16	
20	WMZT3C20		WMZT3D20	
25	WMZT3C25		WMZT3D25	
*30	WMZT3C30		WMZT3D30	
*32	WMZT3C32		WMZT3D32	
*40	WMZT3C40		WMZT3D40	

* Rated 240 VAC



Three-Pole

Miniature Circuit Breaker - UL / CSA		
	C Curve	D Curve
Short Circuit Trip Response	5 - 10 x I _n	10 - 20 x I _n
Current Range	0.5 - 40A	0.5 - 40A
Maximum Voltage Ratings - UL / CSA	0.5 - 25A	277 / 480Y
	30 - 40A	240 VAC
	Per pole	48 VDC
Thermal Tripping Characteristics	Single pole	40°C
	Multi-pole	
Short Circuit Ratings (At Max. Voltage)	1 pole	10 kA
	2 pole	
	3 pole	
Rated Frequency	50 / 60 Hz	

Miniature Circuit Breaker - IEC		
	C Curve	D Curve
Short Circuit Trip Response	5 - 10 x I _n	10 - 20 x I _n
Current Range	0.5 - 40A	0.5 - 40A
Maximum Voltage Ratings - IEC/EN 60947-2	1 pole	240 / 415 VAC
	2 pole	
	3 pole	
Thermal Tripping Characteristics	Single pole	30°C
	Multi-pole	30°C
Interrupt Ratings (At Max Voltage)	15 kA	
Rated Frequency	50 / 60 Hz	

General Specifications - WMZT		
Lifespan / Endurance	≥20,000 (1 operation = ON/OFF)	
Operating Temperature	UL 489, CSA C22.2 No.5 = 40°C IEC 60947-2 = 30°C	
Shock (UL 489)	10g 20-25 ms	
Housing Material	Nylon	
Mounting Position	Vertical	
Weight	One-Pole	0.3 lbs. (136 g)
	Two-Pole	0.6 lbs. (272 g)
	Three-Pole	0.9 lbs. (408 g)

Wire Size - WMZT			
Ampere Rating	Cable Size		
0.5 - 40	One wire	0.75 to 13 mm ²	18 to 6 AWG
	Two wires	0.75 to 5 mm ²	18 to 10 AWG

Note: Eaton does not recommend the use of wire ferrules or crimping terminals. The wire gauges are specified above and in the installation instructions included with each circuit breaker.

Tightening Torque - WMZT		
Cable Size	Tightening Torque	
18 AWG	2.4 Nm	21 lb-in
10 - 8 AWG	2.8 Nm	25 lb-in
6 AWG	4.1 Nm	36 lb-in

EATON WMZT Series Technical Data

Let-Through Energy

Characteristic C (0.5-20A), 277V

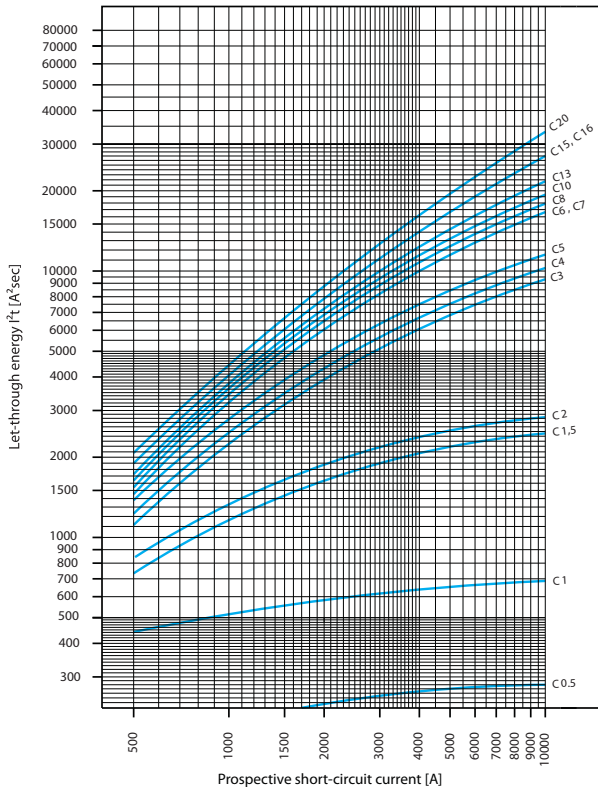

Characteristic C (25-40A), 240V

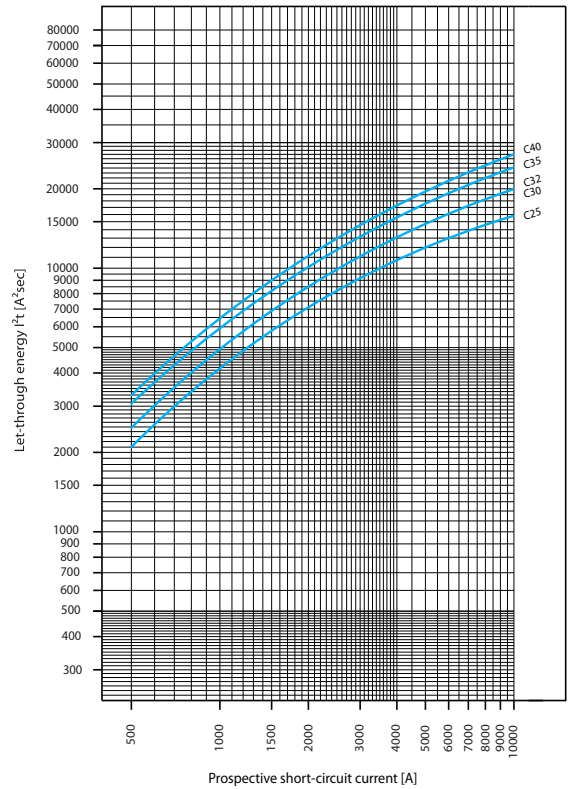

Characteristic D (0.5-20A), 277V

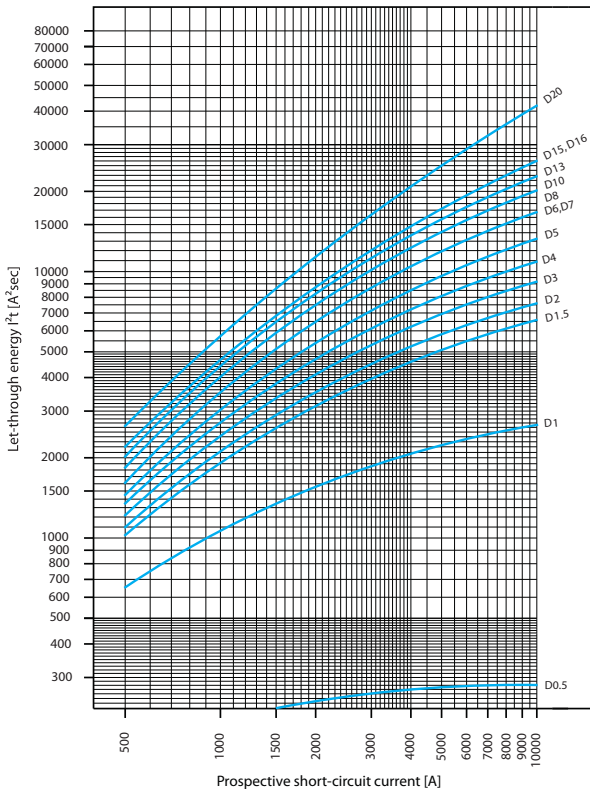

Characteristic D (25-40A), 240V

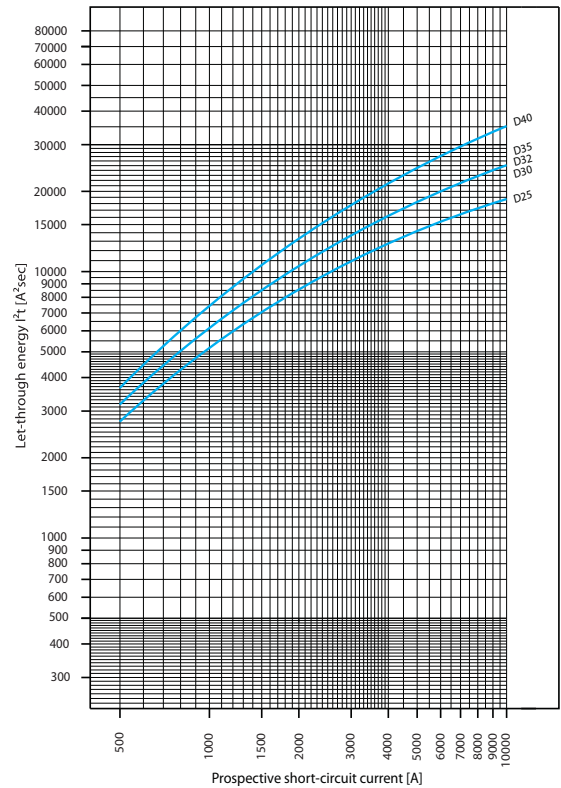

Power Loss at I_n			
Characteristic C			
I_n [A]	1p P[W]	2p P[W]	3p P[W]
0.5	1.6	3.2	4.7
1	1.1	2.2	3.4
1.5	1.3	2.6	3.9
2	1.4	2.8	4.3
3	1.2	2.4	3.6
4	1.4	2.9	4.3
5	1.9	3.7	5.6
6	1.2	2.3	3.5
7	1.4	2.8	4.3
8	1.4	2.8	4.2
10	1.8	3.6	5.3
13	2.4	4.7	7.1
15	1.9	3.8	5.6
16	2.1	4.3	6.4
20	2.9	5.8	8.7
25	3.1	6.2	9.3
30	3.0	6.0	9.0
32	3.4	6.8	10.2
40	4.0	8.1	12.1

Power Loss at I_n			
Characteristic D			
I_n [A]	1p P[W]	2p P[W]	3p P[W]
0.5	1.6	3.2	4.8
1	0.8	1.5	2.3
1.5	1.0	2.1	3.1
2	1.0	2.1	3.1
3	1.2	2.4	3.6
4	1.4	2.9	4.3
5	1.5	2.9	4.4
6	1.2	2.3	3.5
7	1.4	2.8	4.3
8	1.2	2.4	3.7
10	1.5	3.0	4.5
13	2.0	4.1	6.1
15	1.5	3.1	4.6
16	1.7	3.5	5.2
20	1.8	3.7	5.5
25	2.6	5.1	7.7
30	2.7	5.4	8.1
32	3.1	6.2	9.3
40	3.9	7.8	11.6

Tripping Curves

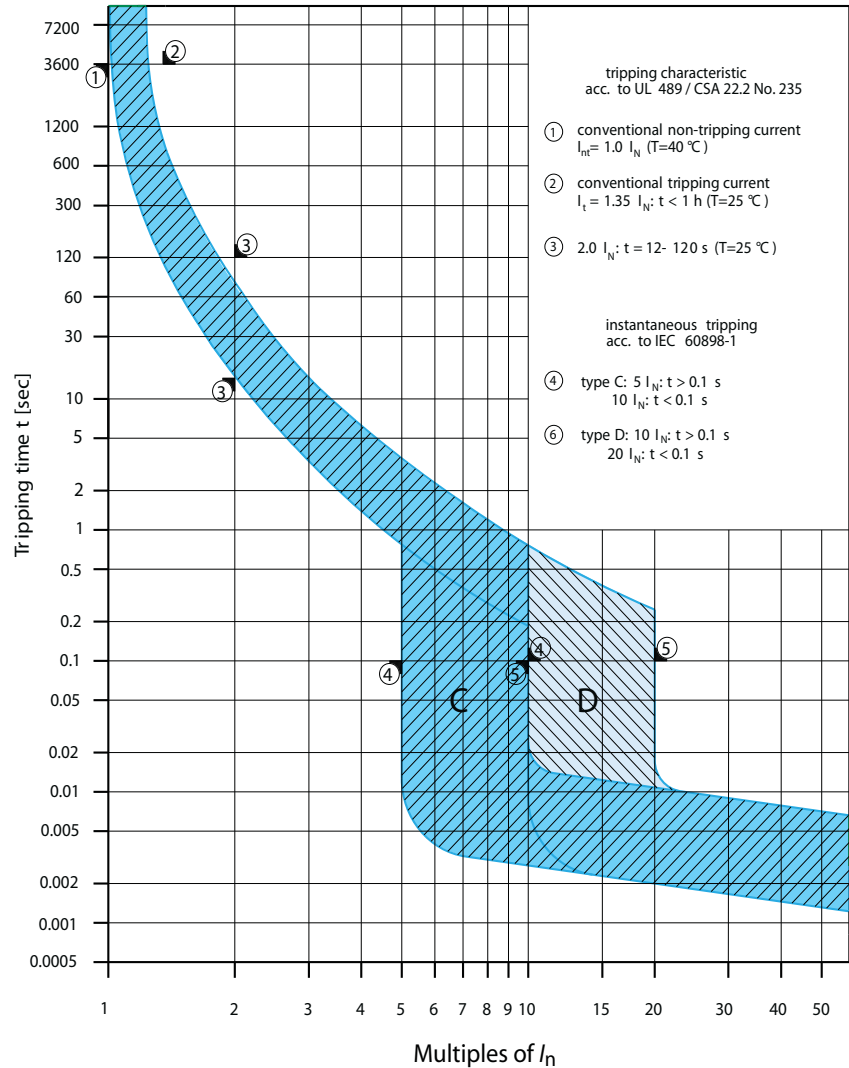

WMZT Miniature Circuit Breakers Dimensions

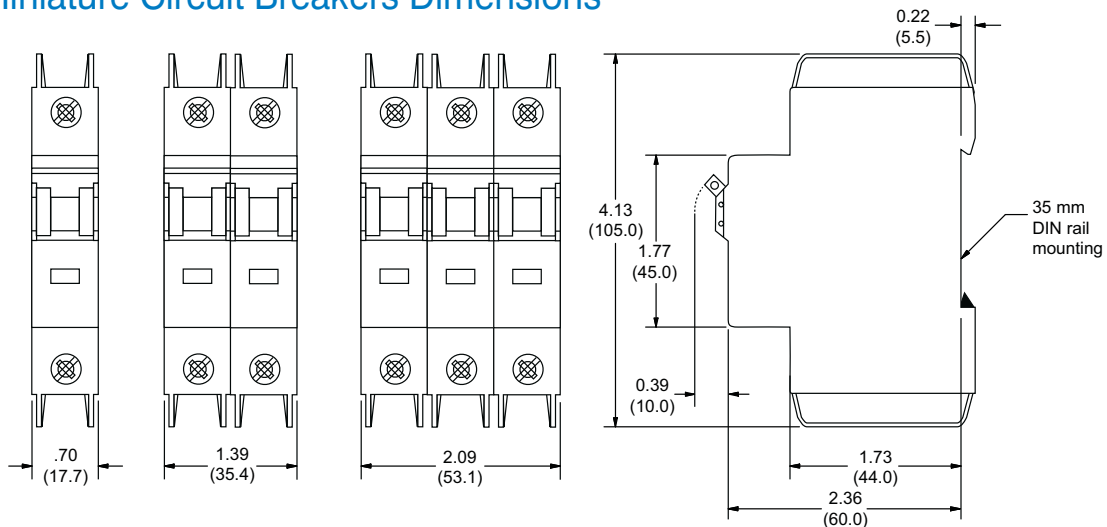

Dimensions are approximate, inches (mm) - Not for construction purposes

Influence of Ambient Temperature T on Load Carrying Capacity									
Device Market Current Rating I_N (A) at 40 °C	I_n (A) at Higher Ambient Temperature								
	15 °C	20 °C	25 °C	30 °C	40 °C	50 °C	55 °C	60 °C	
0.5	0.6	0.5	0.5	0.5	0.5	0.5	0.5	0.5	0.5
1.0	1.1	1.1	1.1	1.0	1.0	1.0	0.9	0.9	0.9
1.5	1.7	1.6	1.6	1.6	1.5	1.4	1.4	1.4	1.4
2.0	2.2	2.2	2.1	2.1	2.0	1.9	1.9	1.8	1.8
3.0	3.3	3.2	3.2	3.1	3.0	2.9	2.9	2.8	2.8
4.0	4.4	4.3	4.2	4.2	4.0	3.8	3.8	3.7	3.7
5.0	5.5	5.4	5.3	5.2	5.0	4.8	4.7	4.6	4.6
6.0	6.6	6.5	6.4	6.2	6.0	5.8	5.6	5.5	5.5
7.0	7.7	7.6	7.4	7.3	7.0	6.7	6.6	6.4	6.4
8.0	8.8	8.6	8.5	8.3	8.0	7.7	7.5	7.4	7.4
10.0	11.0	10.8	10.6	10.4	10.0	9.6	9.4	9.2	9.2
13.0	14.3	14.0	13.8	13.5	13.0	12.5	12.5	12.0	12.0
15.0	16.5	16.2	15.9	15.6	15.0	14.4	14.1	13.8	13.8
16.0	17.6	17.3	17.0	16.6	16.0	15.4	15.0	14.7	14.7
20.0	22.0	21.6	21.2	20.8	20.0	19.2	18.8	18.4	18.4
25.0	27.5	27.0	26.5	26.0	25.0	24.0	23.3	23.0	23.0
30.0	33.0	32.4	31.8	31.2	30.0	28.8	28.2	27.6	27.6
32.0	35.2	34.6	33.9	33.3	32.0	30.7	30.1	29.4	29.4
40.0	44.0	43.2	42.4	41.6	40.0	38.4	37.6	36.8	36.8

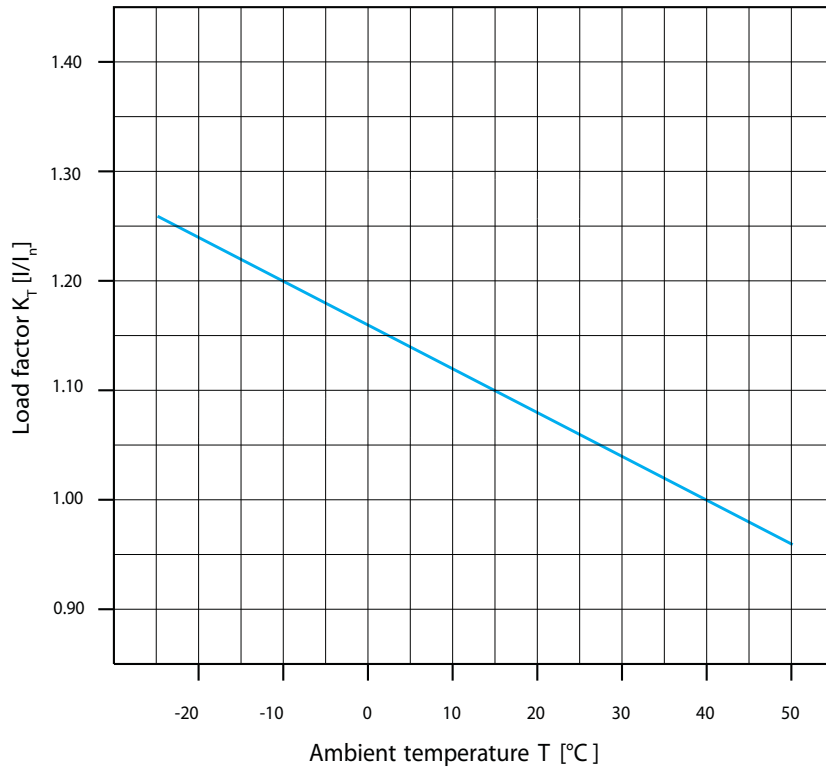

Maximum load I_L at ambient temperature T:
 $I_L(T) = I_N K_T(T)$

- I_L = Maximum Load
- T = Ambient Temperature
- I_N = Rated Current in Amps
- K_T = Load Factor

EAT•N WMZT Series Accessories

Field Mountable Accessories

- Auxiliary switch
- Alarm switch
- Shunt trip
- No tools required for mounting



WMZTAUX
Auxiliary Contact



WMZSAUXTRIP
Alarm/Aux Contact



WMZTSTxxx
Shunt Trip

WMZT Accessories Selection Guide					
Part Number	Description	Contacts	Module Width	Module Weight	Price
WMZTAUX	<ul style="list-style-type: none"> • 1 NO / 1 NC Contact • Installs on left side of WMZT or Shunt Trip • Maximum one per WMZT (489) Device • Switches when WMZT is tripped electrically or manually 	1 NO / 1 NC	0.35" (8.9mm)	0.15 lbs (68 g)	<--->
WMZSAUXTRIP	<ul style="list-style-type: none"> • Two Form C (One set Changeover) contacts, 1 SPDT aux / 1 SPDT alarm • Small selector screw changes mode • Installs on left side of WMZS, WMZT or shunt trip • Auxiliary contacts switch when WMZS or WMZT is tripped electrically or manually. • Trip indicating contact switches only when WMZS or WMZT is tripped electrically. 	(2) Form C			
Part Number	Description	Trip Voltage	Module Width	Module Weight	Price
WMZTST415	<ul style="list-style-type: none"> • Allows remote trip of WMZT • Installs on left side of WMZT 	110 - 415 VAC 110 - 230 VDC	0.69" (17.5mm)	0.28 lbs (127 g)	<--->
WMZTST110		12 - 110 VAC 12 - 60 VDC			

WMZT Accessory Data						
Part Number	Circuit Diagram	Electrical Characteristics	Wire Size (Solid and Stranded)		Terminal Tightening Torque	
			mm ²	AWG	Nm	lb-in
WMZTAUX		Rated for general use, 2 amps at 230 VAC / 0.5 amp at 24/110 VDC 50 / 60 Hz	(1) 0.5 to 2.5 (2) 0.5 to 2.5 (2) 2.5	(1) 20 to 14 (2) 18 to 14 (2) 14	1.2	10.6
WMZSAUXTRIP	See WMZSAUXTRIP diagrams on next page	1 SPDT auxiliary contact and 1 SPDT alarm contact that can be configured and used as an auxiliary contact, rated for general use, 2 amps at 200 VAC / 0.5 amp at 24/110 VDC 50 / 60 Hz	(1) 0.5 to 2.5 (2) 0.5 to 2.5 (2) 1.5	(1) 18 to 14 (2) 18 to 14 (2) 16	0.8	7.0
WMZTST415		110 - 415 VAC, 110 - 230 VDC operating range 0.5 amp at 110 VAC, 2 amp at 415 VAC 0.5 amp at 110 VDC, 1.1 amp at 230 VAC	(1) 1 to 6 (2) 1 to 6 (2) 6	(1) 18 to 10 (2) 18 to 10 (2) 10	2.8	25.0
WMZTST110		12 - 110 VAC, 12 - 60 VDC operating range 0.5 amp at 12 VAC, 4.4 amp at 110 VAC 0.5 amp at 12 VDC, 2.4 amp at 60 VDC				

Allowable Combinations of Accessories

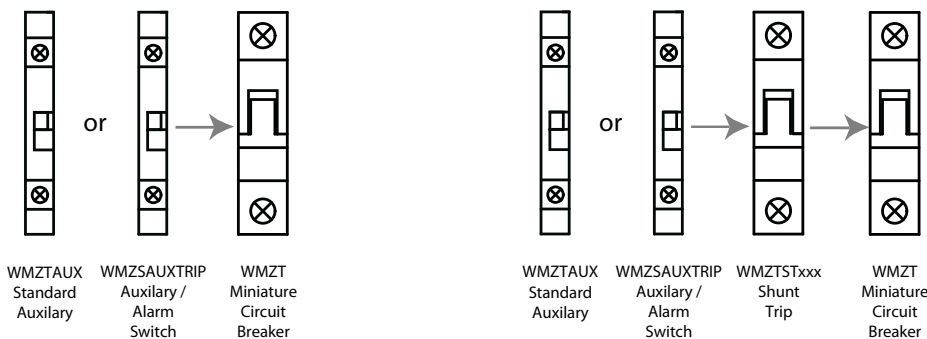

- Company Information
- Systems Overview
- Programmable Controllers
- Field I/O
- Software
- C-more & other HMI
- Drives
- Soft Starters
- Motors & Gearbox
- Steppers/ Servos
- Motor Controls
- Proximity Sensors
- Photo Sensors
- Limit Switches
- Encoders
- Current Sensors
- Pressure Sensors
- Temperature Sensors
- Pushbuttons/ Lights
- Process
- Relays/ Timers
- Comm.
- Terminal Blocks & Wiring
- Power
- Circuit Protection
- Enclosures
- Tools
- Pneumatics
- Safety
- Appendix
- Product Index
- Part # Index

EATON WMZT Series Accessories

Accessories Dimensions

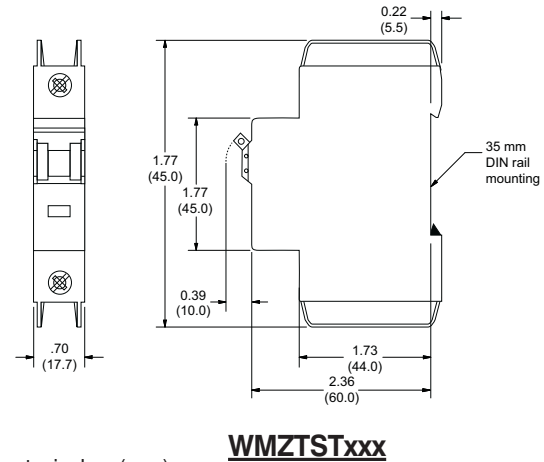
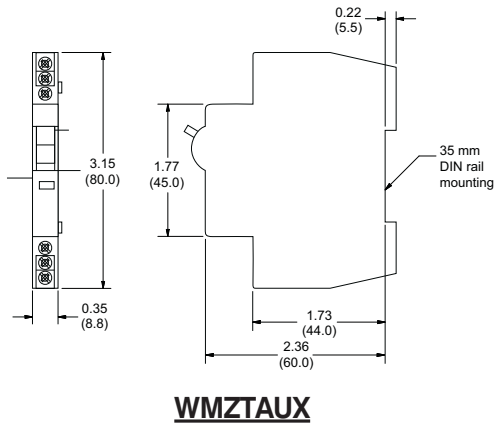
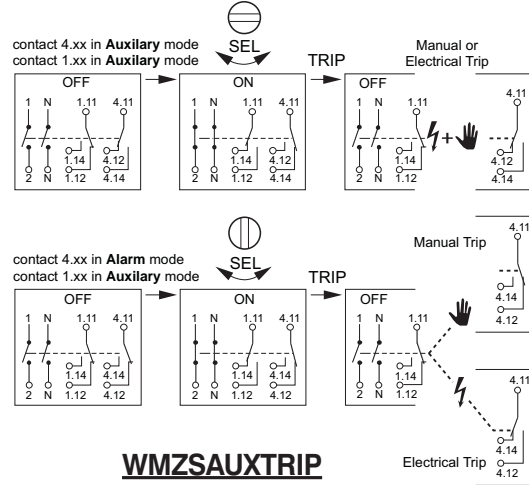
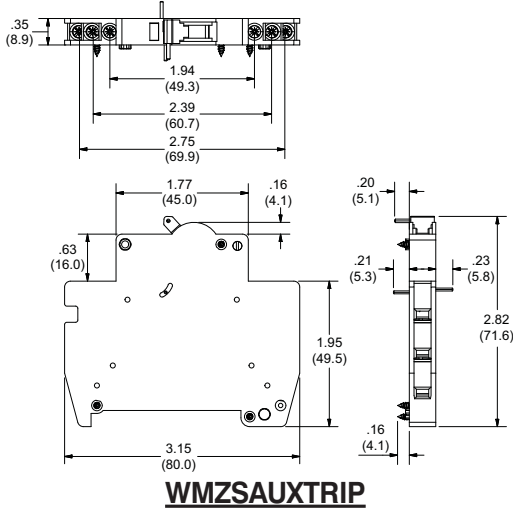

Dimensions are approximate, inches (mm)
- Not for construction purposes

Lockout Attachment



Lockout Attachment

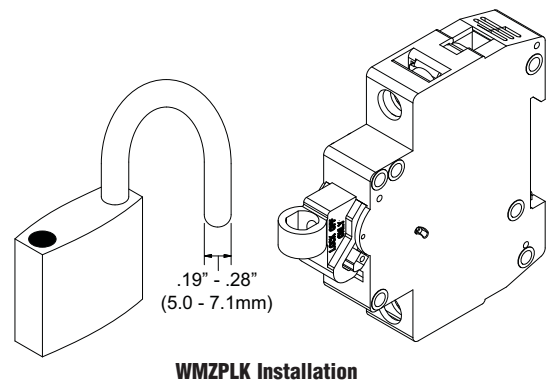

Additional WMZT Accessories			
Part Number	Description	Weight	Price
WMZPLK	Lockout attachment for Eaton WMZS series supplementary protectors and WMZT mini circuit breakers, suitable to prevent unauthorized activation of a de-energized circuit, accepts lock shackles up to 9/32 in. (7.1 mm) in diameter Qty: 5 pieces	0.10 lb (45 g)	<--->

EAT•N WMZT Series Accessories

Bus Bar System



WMZTxP6TSP
WMZT Bus Bar



WMZTxP12TSP
WMZT Bus Bar



WMZTxP18TSP
WMZT Bus Bar

WMZT Bus Bar		
Part Number	Description	Price
WMZT1P6TSP	Bus Bar for connecting up to six (6) 1-pole WMZT series circuit breakers	<--->
WMZT1P12TSP	Bus Bar for connecting up to twelve (12) 1-pole WMZT series circuit breakers	<--->
WMZT1P18TSP	Bus Bar for connecting up to Eighteen (18) 1-pole WMZT series circuit breakers	<--->
WMZT2P6TSP	Bus Bar for connecting up to three (3) 2-pole WMZT series circuit breakers	<--->
WMZT2P12TSP	Bus Bar for connecting up to six (6) 2-pole WMZT series circuit breakers	<--->
WMZT2P18TSP	Bus Bar for connecting up to nine (9) 2-pole WMZT series circuit breakers	<--->
WMZT3P6TSP	Bus Bar for connecting up to two (2) 3-pole WMZT series circuit breakers	<--->
WMZT3P12TSP	Bus Bar for connecting up to four (4) 3-pole WMZT series circuit breakers	<--->
WMZT3P18TSP	Bus Bar for connecting up to six (6) 3-pole WMZT series circuit breakers	<--->

Note: WMZT Bus Bar is not for use with WMZS supplementary protectors.

Bus Bar Specifications			
Description	UL489		IEC/EN60947-2
Operating Voltage	480 VAC	96 VDC	240 / 415 VAC
Frequency	50 / 60 Hz	n/a	50 / 60 Hz
Rated impulse withstand - U_{imp}	n/a		9.5 kV
Max Current - I_e	80A @ 40 °C		80A @ 30 °C
Cross Section	n/a		16 mm ²

Dimensions

Dimensions are approximate, inches (mm)
- Not for construction purposes

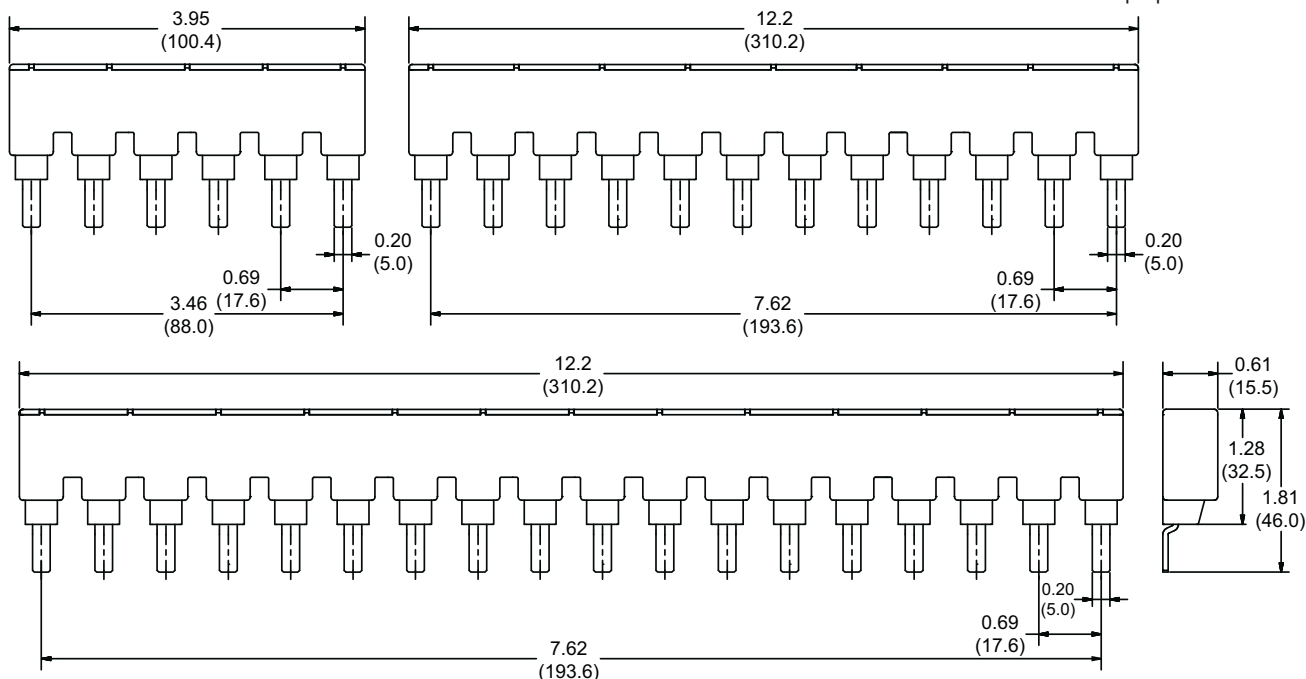

EAT•N WMZT Series Accessories

Bus Bar Accessories



WMZT3PSHROUD
Bus Bar Shroud



WMZT35EXT
Wiring Lug

WMZT Bus Bar Accessories		
Part Number	Description	Price
WMZT3PSHROUD	Bus Bar Shroud - covers for unused bus bar terminals, (10) 3-terminal covers per package	<-->
WMZT35EXT	Wiring Lug, 35mm (2 - 14 AWG), 3 lugs per package	<-->

WMZT35EXT - Specifications			
Description	UL489		IEC/EN60947-2
Operating Voltage	480 VAC	96 VDC	240 / 415 VAC
Frequency	50 / 60 Hz	n/a	50 / 60 Hz
Rated impulse withstand - U_{imp}	n/a		9.5 kV
Max Current - I_e	80A @ 40 °C		80A @ 30 °C
	#2 - 14 AWG		2.5 - 35 mm ²
	0.56 in		14 mm

WMZT35EXT - Tightening Torque		
Tested Acc. To	Cable Size	Tightening Torque
UL 486A	#14 AWG	≥ 2.3 Nm (20 lb-in)
UL 486B	#8 - 12 AWG	≥ 2.8 Nm (25 lb-in)
UL 486E	#6 - 1 AWG	4 Nm (35 lb-in)

Dimensions

