

CO-04TRS-10 CLICK Expansion I/O Module

Please read and understand the information in this insert prior to installation, operation, or servicing this equipment. Please refer to the CLICK User

Manual (CO-USER-M) for more information (<https://cdn.automationdirect.com/static/manuals/cUserm/cUserm.html>).

3505 HUTCHINSON ROAD
CUMMING, GA 30040-5860



CO-04TRS-10

General Safety

Please follow the instructions below for personal and operational safety.

In this Insert Sheet, the safety instruction levels are classified into “WARNING” and “CAUTION”



WARNING

Assumes that incorrect handling may cause hazardous conditions, resulting in severe injury or death.



CAUTION

Assumes that incorrect handling may cause hazardous conditions, resulting in medium or slight injury, or may cause equipment damage.



WARNING

- Don't use this equipment in a flammable or explosive environment in order to avoid accidental injury or fire.
- You should use external electromechanical devices that are independent of the PLC (Programmable Logic Controller) system to provide protection for any part of the system; otherwise malfunction or output failures may result in a hazardous accident.
- When using this product, connect it to the Click CPU unit.
- Please ensure to earth the Ground terminal of the Power Units for CLICK CPU (CO-00AC/01AC) to avoid electric shock or equipment damage during a short circuit.
- Don't operate the equipment with a nonconforming external power supply to avoid electric shock, equipment damage or fire.
- Don't intentionally fault wiring; this may cause equipment damage or fire.
- To avoid electric shock or malfunctions which might result in an accident, don't touch any terminal while the PLC power is on.
- Don't put metals (e.g. Screwdriver) into radiator holes, drop trash, or foreign objects (e.g. wire cut-offs) into the device, in order to avoid electric shock or equipment damage.
- If the equipment is used in a manner not specified by the manufacturer, the protection provided by the equipment may be invalidated.



CAUTION

- Use and store the equipment in an environment described in the specifications (regarding temperature, humidity, vibrations, shock, etc.) in order to avoid equipment damage or fire.
- Ensure all wiring has strain reliefs in order to avoid damage to insulation that might result in electric shock or fire.
- Ensure secondary external power circuits are only live after PLC control program is started; otherwise a malfunction or output failure may result in a hazardous accident.
- Don't block the radiator holes. This may cause an increase of internal temperature resulting in equipment damage or fire.
- Don't disassemble or modify equipment so as to avoid electric shock, equipment damage, or fire.
- Cut off all phases of the external power source before maintenance work, thus avoiding electric shock or equipment damage.

General Specifications⁺

Operating Temperature	32° to 131°F (0° to 55°C)
Storage Temperature	-4° to 158°F (-20° to 70°C)
Relative Humidity	30% to 95% (non-condensing)
Environmental Air	No corrosive gases permitted (Level 2 environmental pollution)*
Altitude	Up to 2000m
Agency Approvals	UL61010-2-201 CE (EN61131-2):2007* RoHS (2011/65/EU) and amendment (EU) 2015/863

⁺ Keep out iron powder, moisture, oil or chemicals. Isolate from shock or vibration, direct sunlight, and from electric or ferromagnetic field.

* Meets EMC and Safety requirements. See the Declaration of Compliance for details.

Output Specifications

Outputs per Module	4
Peak Voltage	24VDC; 264VAC
Operating Voltage Range	6–24 VDC; 6–240 VAC
Output type	4 Relays, FORM A (SPST)
AC Frequency	47–63 Hz
Maximum Output Current	10A / point 10A / common
Minimum Load Current	100mA @ 5VDC
Maximum Inrush Current	16A for 10ms
OFF to ON Response	< 15ms
ON to OFF Response	< 15ms
Status Indicators	Logic Side (4 points, red LED) Power Indicator (green LED)
Commons	4 (1 point / common)
Bus Power Required (24V)	Max. 120mA (all points ON)

CO-04TRS-10 CLICK Expansion I/O Module

Installation and Mounting

1. Safety Installation, Wiring or Handling
 - Discharge static electricity before installation or wiring in order to avoid electric equipment damage.
2. Preface
 - CLICK CO-04TRS-10 is supported by CLICK Programming software Ver 2.60 or higher.
3. Compliant Crimp-type terminal
 - I/O terminals
4. The following crimping ferrules are recommended for 24VDC terminal and I/O terminals of CPU and Expansion I/O.

Company	Series	Model No.	Compliant Wire
Zoller+Fröhlich	Twin Ferrules	V30AE001134	* 0.5 mm ² (20AWG)

* Rated torque is 0.5 N·m. Take care not to contact adjacent terminal.

5. Safety Standard
 - To comply with safety standards, please observe and use the following.

Please use SELV (as defined by UL61010-2-201) and Limited Energy (as defined by UL61010-1, 9.4)

Please ensure basic isolation is provided between each relay block.

In order to comply with IEC/UL 61010-2-201 if the output is connected to a circuit lower than 30V, please provide an external isolation before the relay output terminals. Basic isolation requires an air separation of at least 1.5 mm, a creepage distance of at least 2.5 mm, and a withstand voltage of 1500V rms.

Installing Expansion I/O Modules:

- Remove protective cover over bus port.
- Push the LOCK slide (top and bottom of modules) to "UNLOCK".
- Align module pins and tabs (attachment of modules) into adjacent slots and firmly push together.
- Push the LOCK slides to "LOCK" to lock modules rigidly together.

Modules easily connect to each other.

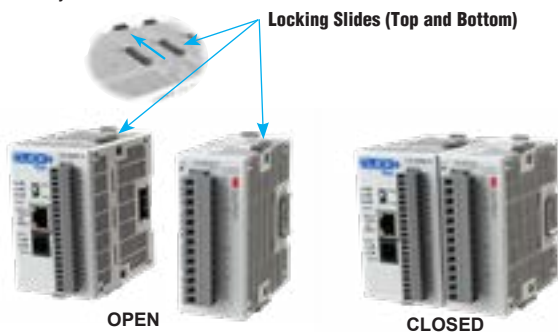

To remove an I/O module, first disconnect all phases of external power source and wait **5 seconds** before installing or removing the expansion I/O module of a functioning system.

Then push LOCK slides to "UNLOCK" and gently separate modules.

Safety Installation

Please heed the following instructions when installing:

- Mount the CLICK PLC unit horizontally to provide proper ventilation.
- Do not mount the CLICK PLC unit upside down, on a horizontal surface, or in a vertical arrangement.
- There is a minimum clearance requirement of 2in. (51mm) from all sides of the cabinet and the equipment.
- There is a minimum clearance requirement of 3in. (76mm) from the wiring ducts and the equipment.
- Please use this product in a metal enclosure/cabinet.

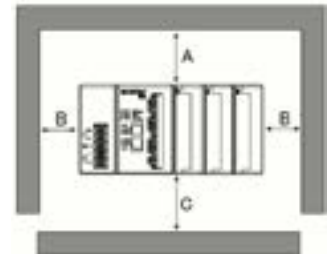

Minimum clearance requirement of 51mm for A, B, and C.

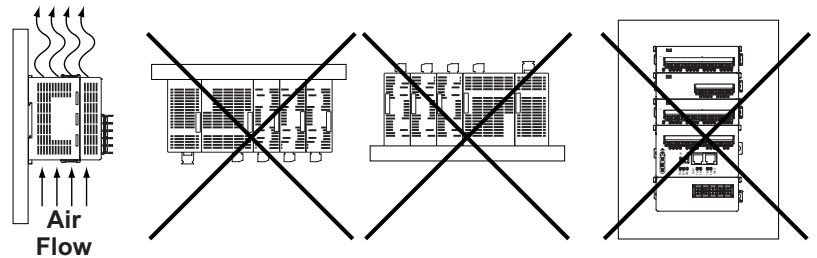

Enclosures

It is important to select the appropriate enclosure to ensure safe and proper operation of your CLICK PLC system. Control applications vary and yours may require additional considerations. At a minimum your enclosure should include:

- Conformance to electrical standards
- Protection from the elements in an industrial environment
- Common ground reference
- Maintenance of specified ambient temperature
- Access to equipment
- Security or restricted access
- Sufficient space for proper installation and maintenance of equipment

CAUTION

- When installing modules and CPU on DIN rails, always use end brackets on both ends of assembly.
- You should use 35mm width DIN Rails.
- You should use M4 size screws when you surface mount.
- You should tighten the screws with a spring washer and a small round washer and torque (0.5 to 0.6 N·m).

CAUTION

Do not operate without first installing safety cover over power supply leads.

Additional Help and Support

- For additional technical support or questions, call our Technical Support team @ 1-800-633-0405 or 770-844-4200



CO-04TRS-10 CLICK Expansion I/O Module

Equivalent Circuit Diagram:

Wiring Diagram:

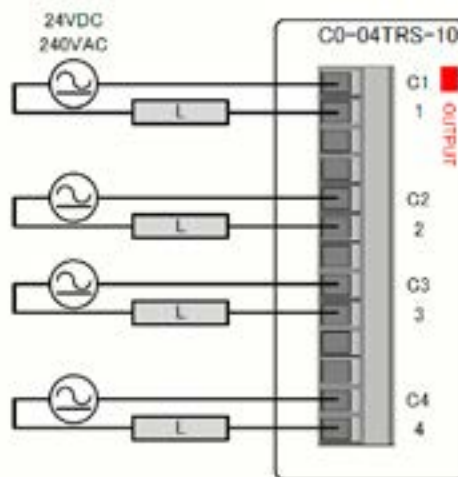
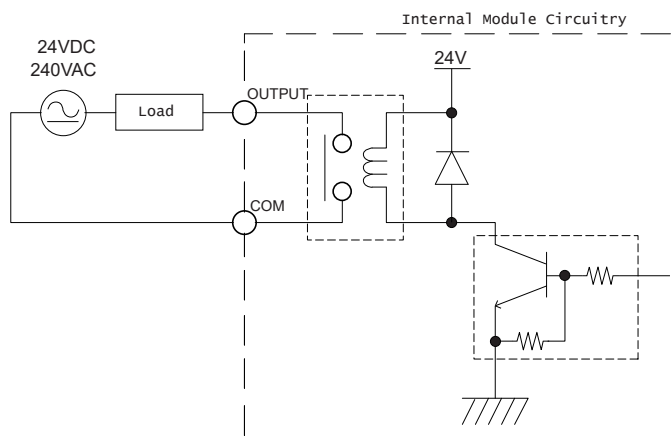

Dimensional Drawings:

