

SPECIFICATIONS



CHAPTER 2

In This Chapter...

| | |
|--|-------|
| Overview of PLC System | 2-2 |
| PLC Units | 2-3 |
| I/O Modules | 2-10 |
| Programming Software | 2-14 |
| Data Types, Memory, and Numbering System | 2-15 |
| PLC Operation..... | 2-19 |
| Power Budgeting..... | 2-23 |
| General Specifications | 2-26 |
| PLC Unit Specifications | 2-27 |
| Basic PLC Unit Specifications | 2-36 |
| Standard PLC Unit Specifications..... | 2-44 |
| Analog PLC Unit Specifications..... | 2-52 |
| Ethernet Basic PLC Unit Specifications | 2-61 |
| Ethernet Standard PLC Unit Specifications..... | 2-69 |
| Ethernet Analog PLC Unit Specifications | 2-77 |
| I/O Module Specifications | 2-113 |
| Power Supply Specifications..... | 2-149 |
| Accessories..... | 2-150 |

Overview of PLC System

The CLICK PLC family of components is designed to combine practical PLC features in a compact and expandable design, with a simple-to-use philosophy. A powered CLICK PLC unit by itself can be used as a complete PLC system with built-in I/O points, or the system can be expanded with the addition of up to eight I/O modules. The CLICK PLC system does not require a mounting base. The CLICK PLC and I/O modules are connected together via an expansion port on the right side of the PLC case. A variety of I/O modules are available for flexible and optimal system configuration. The CLICK PLC supports a very simple but useful instruction set. There are 21 easy-to-use instructions that cover most applications that are suitable for this class of PLC.

Use a CLICK PLC unit as a stand-alone controller..

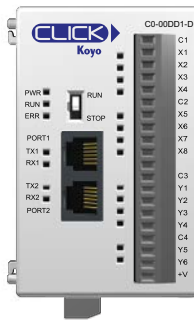

or, expand the system by installing up to eight additional I/O modules.

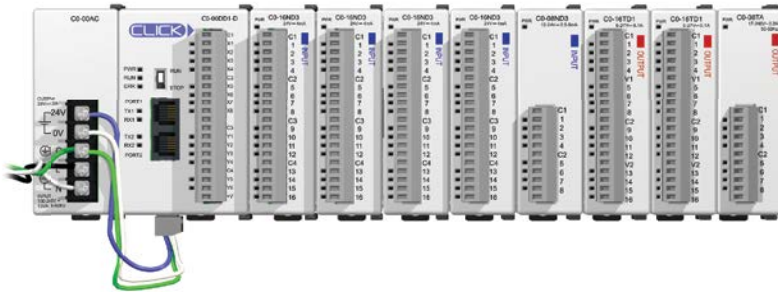

NOTE: It is not necessary to use the CLICK PLC with a CLICK power supply. An alternately regulated, properly-sized 24VDC power source can be used to power the PLC and can also provide 24VDC to any optional I/O modules used in the CLICK PLC hardware configuration. Please refer to the Power Budgeting section later in this chapter for details on choosing the correct size power supply.

PLC Units

All CLICK PLC units offer the same instruction set, and support all optional I/O modules. The six types of PLC units available are listed in the table below.

| PLC Types | Discrete I/O | | Analog I/O | | Communication Ports | | | Battery Backup | RUN time Edit |
|-------------------|--------------|---------|------------|---------|---------------------|--------|--------|----------------|---------------|
| | Inputs | Outputs | Inputs | Outputs | Port 1 | Port 2 | Port 3 | | |
| Basic | 8 | 6 | N/A | N/A | RS-232 | RS-232 | N/A | Yes | N/A |
| Standard | 8 | 6 | | | | | | | |
| Analog | 4 | 4 | 2 | 2 | | | | | |
| Ethernet Basic | 8 | 6 | N/A | N/A | Ethernet | RS-232 | N/A | Yes | Yes |
| Ethernet Standard | 8 | 6 | | | | | | | |
| Ethernet Analog | 4 | 4 | 2 | 2 | | | | | |
| | | | 4 | 2 | | | RS-485 | | |

Basic PLC Units

The Basic CLICK PLC units are available with different combinations of built-in I/O (i.e. DC input/DC output, DC input/relay output, and AC input/relay output).

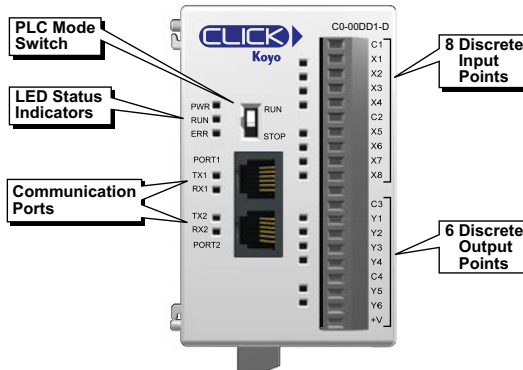

Built-in I/O (Basic PLC Units)

There are four different configurations of I/O types available for the Basic CLICK PLC units. The table below lists the part numbers showing the various I/O configurations.

| Basic PLCs | | | |
|-------------|---------------------|----------------------|------------------------------------|
| Part Number | Discrete Input Type | Discrete Output Type | External Power |
| C0-00DD1-D | 8 DC (sink/source) | 6 DC (sink) | 24VDC (required for all PLC units) |
| C0-00DD2-D | | 6 DC (source) | |
| C0-00DR-D | | 6 Relay | |
| C0-00AR-D | 8 AC | | |

Standard PLC Units

The Standard CLICK PLC units are available with different combinations of built-in I/O types (i.e. DC input/DC output, DC input/relay output, and AC input/relay output).

They also have an RS-485 port for Modbus RTU and ASCII communications, and the battery backup feature which will retain the data in SRAM for 3 years.

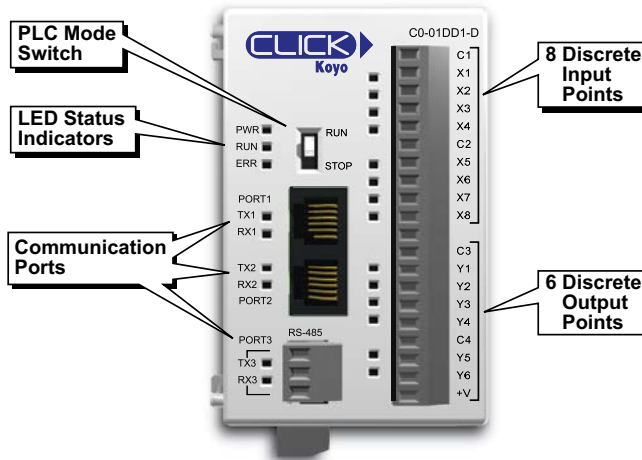

Built-in I/O (Standard PLC Units)

There are four different configurations of I/O types available for the Standard CLICK PLC units. The table below lists the part numbers showing the various I/O configurations.

| Standard PLCs | | | |
|---------------|---------------------|----------------------|------------------------------------|
| Part Number | Discrete Input Type | Discrete Output Type | External Power |
| C0-01DD1-D | 8 DC (sink/source) | 6 DC (sink) | 24VDC (required for all PLC units) |
| C0-01DD2-D | | 6 DC (source) | |
| C0-01DR-D | | 6 Relay | |
| C0-01AR-D | 8 AC | | |

Analog PLC Units

The Analog CLICK PLC units are available with different combinations of DC in, DC sinking, sourcing or relay out, and analog in and out.

They also have an RS-485 port for Modbus RTU and ASCII communications, and the battery backup feature which will retain the data in SRAM for 3 years.

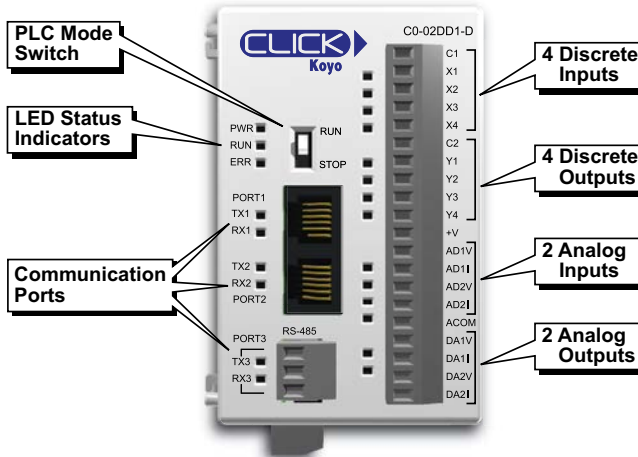

Built-in I/O (Analog PLC Units)

There are three different configurations of I/O types available for the Analog CLICK PLC units. The table below lists the part numbers showing the various I/O configurations.

| Analog PLCs | | | | | |
|-------------|------------------------|-----------------------|---|---|---------------------------------------|
| Part Number | Discrete Input Types | Discrete Output Types | Analog Input Types | Analog Output Types | External Power |
| C0-02DD1-D | 4 DC (sink/ source) | 4 DC (sink) | 2 channel; voltage (0–5 VDC) / current (4–20 mA); selectable separately per channel, 12-bit | 2 channel; voltage (0–5 VDC) / current (4–20 mA); selectable separately per channel, 12-bit | 24VDC (required for all PLC units) |
| C0-02DD2-D | | 4 DC (source) | | | |
| C0-02DR-D | | 4 relay | | | |



NOTE: There is a dedicated terminal for each voltage or current type, but you must also select the voltage or current type in the CLICK programming software. See the Analog I/O Configuration section in Chapter 3.

Ethernet Basic PLC Units

The Ethernet Basic CLICK PLC units are available with different combinations of built-in I/O types, e.g. DC input /DC output, DC input/relay output, and AC input/relay output. Four types of Ethernet Basic PLC units are available.

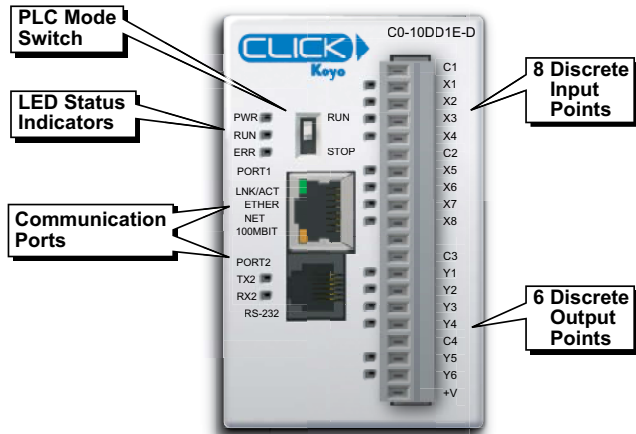

Built-in I/O (Ethernet Basic PLC Units)

There are four different configurations of I/O types available for the Ethernet Basic CLICK PLC units. The table below lists the part numbers showing the various I/O configurations.

| Ethernet Basic PLCs | | | |
|---------------------|---|----------------------|---------------------------------------|
| Part Number | Discrete Input Type | Discrete Output Type | External Power |
| C0-10DD1E-D | 8 DC (sink/source) 4 points High-Speed | 6 DC (sink) | 24VDC (required for all PLC units) |
| C0-10DD2E-D | | 6 DC (source) | |
| C0-10DRE-D | | 6 Relay | |
| C0-10ARE-D | 8 AC | | |

Ethernet Standard PLC Units

The Ethernet Standard CLICK PLC units are available with different combinations of built-in I/O types, e.g., DC input /DC output, DC input/relay output, and AC input/relay output.

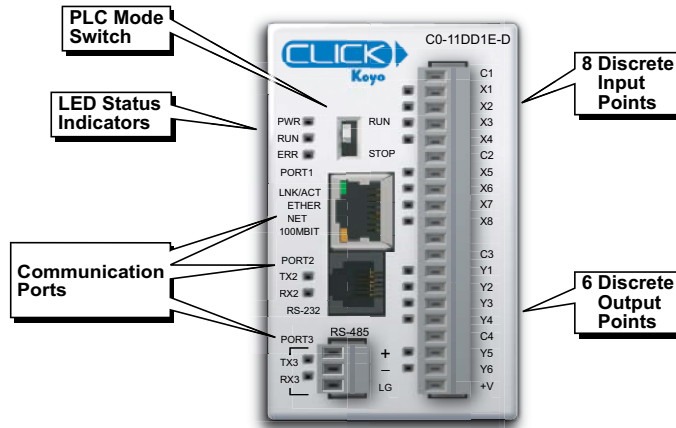

Built-in I/O (Ethernet Standard PLC Units)

There are four different configurations of I/O types available for the Ethernet Standard CLICK PLC units. The table below lists the part numbers showing the various I/O configurations.

| Ethernet Standard PLCs | | | |
|------------------------|---|----------------------|---------------------------------------|
| Part Number | Discrete Input Type | Discrete Output Type | External Power |
| C0-11DD1E-D | 8 DC (sink/source) 8 points High-Speed | 6 DC (sink) | 24VDC (required for all PLC units) |
| C0-11DD2E-D | | 6 DC (source) | |
| C0-11DRE-D | | 6 Relay | |
| C0-11ARE-D | | | |

Ethernet Analog PLC Units

The Ethernet Analog CLICK PLC units are available with different combinations of built-in I/O types, e.g., DC input /DC output, DC input/relay output, and AC input/relay output, and analog in and out.

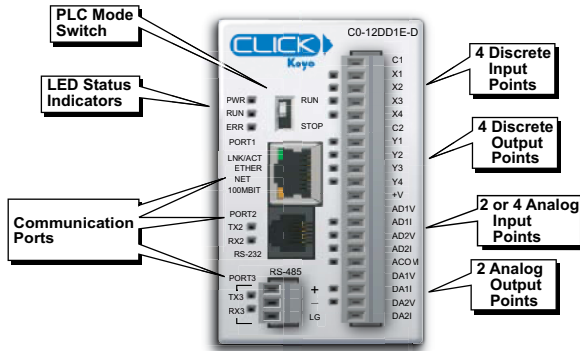

Built-in I/O (Ethernet Analog PLC units)

There are twelve different configurations of I/O types available for the Ethernet Analog CLICK PLC units. The table below lists the part numbers showing the various I/O types.

| Ethernet Analog PLCs | | | | | |
|----------------------|----------------------|-----------------------|---|---|--|
| Part Number | Discrete Input Types | Discrete Output Types | Analog Input Types | Analog Output Types | External Power |
| C0-12DD1E-D* | 4 DC | 4 DC (sink) | 2 channel; voltage (0–5 VDC) / current (4–20 mA); selectable separately per channel, 12-bit | 2 channel; voltage (0–5 VDC) / current (4–20 mA); selectable separately per channel, 12-bit | 24VDC (Required for all PLC units) |
| C0-12DD2E-D* | (sink/source) | 4 DC (source) | | | |
| C0-12DRE-D* | 4 points High-Speed | 4 relay | | | |
| C0-12ARE-D* | 4 AC | | | | |
| C0-12DD1E-1-D | 4 DC | 4 DC (sink) | 4 channel; current (0–20 mA), 12-bit | 2 channel; current (4–20 mA), 12-bit | |
| C0-12DD2E-1-D | (sink/source) | 4 DC (source) | | | |
| C0-12DRE-1-D | 4 points High-Speed | 4 relay | | | |
| C0-12ARE-1-D | 4 AC | | | | |
| C0-12DD1E-2-D | 4 DC | 4 DC (sink) | 4 channel; voltage (0–10 VDC), 12-bit | 2 channel; voltage (0–10 VDC), 12-bit | |
| C0-12DD2E-2-D | (sink/source) | 4 DC (source) | | | |
| C0-12DRE-2-D | 4 points High-Speed | 4 relay | | | |
| C0-12ARE-2-D | 4 AC | | | | |

* These four PLC units require that you select I/O as voltage or current type in the CLICK programming software. See the Analog I/O Configuration section in Chapter 3.

Communication Ports

The Basic CLICK PLC units have two built-in RS-232 serial communications ports. Standard and Analog PLC units also have an additional RS-485 port. All CLICK Ethernet PLC units have one built-in Ethernet communication port and one RS-232 serial communication port. Ethernet Standard and Ethernet Analog PLC units also have an additional RS-485 port. See Chapter 4: *Communications* for details on the proper use of these ports.

Memory

All CLICK PLC units have a non-volatile FLASH ROM to store the downloaded ladder program and project file. The FLASH ROM will retain the ladder program even with power removed from the PLC module.

The CLICK PLC units make use of data registers to store values and conditions that are used during program execution. This data is stored in the SRAM memory. It is volatile memory, but is backed up by a super capacitor. The super capacitor is a special type of capacitor that is designed to provide power to volatile memory like the SRAM when the power to the PLC is off. However, it will not back up the memory for an extended time. In the case of the CLICK PLC, the super capacitor will back up the SRAM for the following period after the power is shut off. Once the super capacitor is discharged, all data in the SRAM is cleared when the CLICK PLC is powered up the next time.

| CLICK PLC Unit | Backup Period by the Super Capacitor |
|-----------------------------|--------------------------------------|
| Basic PLC units | 7 days |
| Standard PLC units | |
| Analog PLC units | |
| Ethernet Basic PLC units | 1 hour |
| Ethernet Standard PLC units | |
| Ethernet Analog PLC units | |

(Standard, Analog and Ethernet PLC Units Only)

Standard, Analog and all Ethernet PLC units have a battery backup feature that will retain data in the SRAM for three years. Use part number D2-BAT-1 as the replacement battery.

Refer to the PLC Unit Specifications section later in this chapter for more PLC information.

I/O Modules

A variety of I/O modules is available for the CLICK PLC System. Up to 8 I/O modules can be connected to a CLICK PLC unit to expand the system I/O count and meet the needs of a specific application. Complete I/O module specifications and wiring diagrams can be found later in this chapter. Here are the I/O modules that are supported by the CLICK PLC system at this time.

Discrete Input Modules

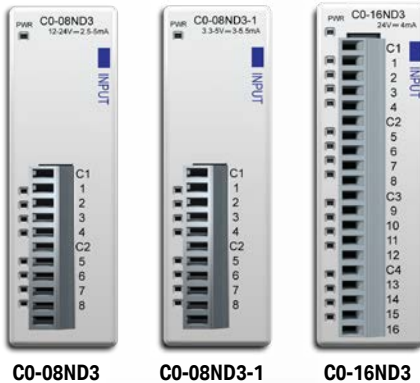

| Discrete Input Modules | | |
|------------------------|------------------------|-----------------|
| Part Number | Input Type | Voltage Ratings |
| CO-08ND3 | 8 DC (Sink/Source) | 12-24VDC |
| CO-08ND3-1 | 8 DC (Sink/Source) | 3.3-5 VDC |
| CO-16ND3 | 16 DC (Sink/Source) | 24VDC |
| CO-08NE3 | 8 AC/DC (Sink/Source) | 24 VAC/VDC |
| CO-16NE3 | 16 AC/DC (Sink/Source) | 24 VAC/VDC |
| CO-08NA | 8 AC | 100-120 VAC |

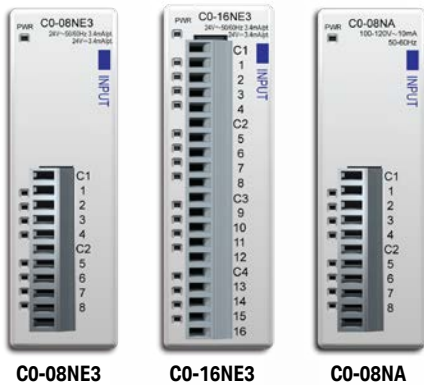

Specialty Modules

| Specialty Modules | | |
|-------------------|------------------|-----------------|
| Part Number | Input Type | Voltage Ratings |
| CO-08SIM | 8, Toggle Switch | N/A |

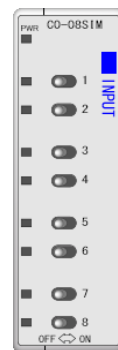

CO-08SIM

Discrete Output Modules

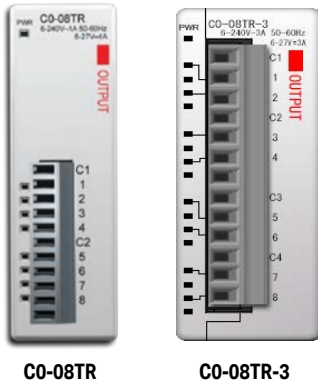
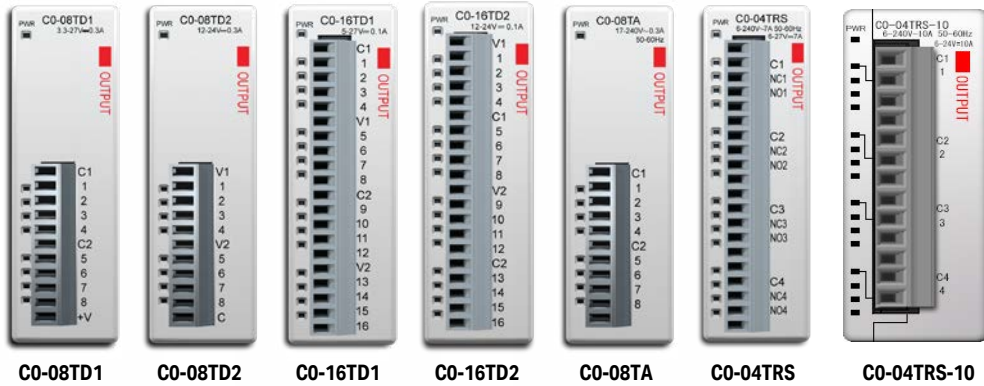

| Discrete Output Modules | | |
|-------------------------|----------------|-----------------------------------|
| Part Number | Output Type | Voltage/Current Ratings |
| CO-08TD1 | 8 DC (Sink) | 3.3-27 VDC / 0.3 A |
| CO-08TD2 | 8 DC (Source) | 12-24 VDC / 0.3 A |
| CO-16TD1 | 16 DC (Sink) | 5-27 VDC / 0.1 A |
| CO-16TD2 | 16 DC (Source) | 12-24 VDC / 0.1 A |
| CO-08TA | 8 AC | 17-240 VAC / 0.3 A |
| CO-04TRS | 4 Relay | 6-27 VDC / 7A 6-240 VAC / 7A |
| CO-04TRS-10 | 4 Relay | 6-24 VDC / 10A 6-240 VAC / 10A |
| CO-08TR | 8 Relay | 6-27 VDC / 1A 6-240 VAC / 1A |
| CO-08TR-3 | 8 Relay | 6-27 VDC / 3A 6-240 VAC / 3A |

Discrete Combo I/O Modules

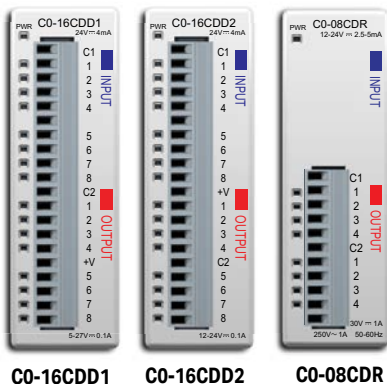

| Discrete Combo I/O Modules | | | | |
|----------------------------|--------------------|---------------|---------------|------------------------------------|
| Part Number | Input Type | Input Voltage | Output Type | Output Voltage / Current Ratings |
| CO-16CDD1 | 8 DC (sink/source) | 24VDC | 8 DC (sink) | 5-27 VDC / 0.1 A |
| CO-16CDD2 | 8 DC (sink/source) | 24VDC | 8 DC (source) | 12-24 VDC / 0.1 A |
| CO-08CDR | 4 DC (sink/source) | 12-24 VDC | 4 (relay) | 6.25-24 VDC / 1A 6-240 VAC / 1A |

Chapter 2: Specifications

Analog Input Modules

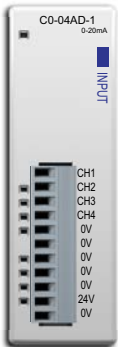

C0-04AD-1

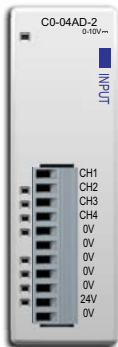

C0-04AD-2

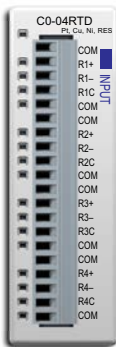

C0-04RTD



C0-04THM

| Analog Input Modules | | |
|----------------------|--|-------------------------|
| Part Number | Analog Input Types | External Power Required |
| C0-04AD-1 | 4 channel, current (0–20 mA), 13-bit | 24VDC |
| C0-04AD-2 | 4 channel, voltage (0–10 V), 13-bit | 24VDC |
| C0-04RTD | 4 channel RTD input (0.1 degree °C/°F resolution), or resistive input (0–3125 Ω, 0.1 Ω or 0.01 Ω resolution) | None |
| C0-04THM | 4 channel thermocouple input (0.1 degree °C/°F resolution), or voltage input (-156.25 mV to 1.25 V, 16-bit) | None |

Analog Output Modules

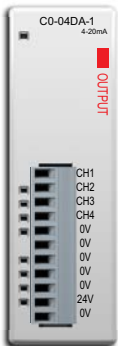

C0-04DA-1



C0-04DA-2

| Analog Output Modules | | |
|-----------------------|---|-------------------------|
| Part Number | Analog Output Types | External Power Required |
| C0-04DA-1 | 4 channel, current sourcing (4–20 mA), 12-bit | 24VDC |
| C0-04DA-2 | 4 channel, voltage (0–10 V), 12-bit | 24VDC |

Analog Combo I/O Modules

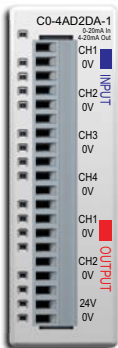

C0-4AD2DA-1

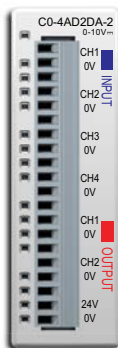



C0-4AD2DA-2

| Analog Combo I/O Modules | | | |
|--------------------------|--------------------------------------|---|-------------------------|
| Part Number | Analog Input Type | Analog Output Type | External Power Required |
| C0-4AD2DA-1 | 4 channel, current (0–20 mA), 13-bit | 2 channel, current sourcing (4–20 mA), 12-bit | 24VDC |
| C0-4AD2DA-2 | 4 channel, voltage (0–10 V), 13-bit | 4 channel, voltage (0–10 V), 12-bit | 24VDC |

Power Supply

Two types of 24VDC power supplies are available for the CLICK PLC family. They are designed to attach to the left side of the CLICK PLC, creating a compact footprint. They are identical except for the output current rating. The 24VDC power is wired from the DC output terminals of the power supply to a removable power terminal block located on the bottom of the CLICK PLC unit.

C0-00AC
0.5 A

C0-01AC
1.3 A

| CLICK 24VDC Power Supply Ratings | |
|----------------------------------|----------------|
| Part Number | Output Current |
| C0-00AC | 0.5 A |
| C0-01AC | 1.3 A |

C0-00AC

The C0-00AC is a low-cost solution for applications requiring only minimal I/O and power consumption. This power supply will not support a fully-populated CLICK PLC system with all possible I/O module combinations.

C0-01AC

The C0-01AC is designed to support a fully-populated CLICK PLC system with all possible I/O module combinations with no concerns of exceeding the power budget.

Please refer to the Power Supply Specifications section later in this chapter for specification details.



NOTE: It is not mandatory to use one of the above CLICK power supplies for the CLICK PLC system. A properly-sized and rated 24VDC power supply, such as some of those offered by Automationdirect.com, can also be used to power a CLICK PLC system.



| 12 VDC-to-24VDC Converter | | |
|---------------------------|---------------|----------------|
| Part Number | Input Voltage | Output Current |
| PSP24-DC12-1 | 9.5-18 VDC | 1.0A @ 24VDC |

PSP24-DC12-1

With this DC-DC converter you can operate the CLICK PLC with 12VDC input power. To select a power supply to use with your CLICK PLC system, you need to consider the total PLC system's power budget. Please refer to the Power Budget section of this chapter for details.

Programming Software

The CLICK PLC Programming Software, which can be downloaded free from the Automationdirect.com web site (Downloads/Software), is designed to provide simple and fast application development of ladder logic programming.

These are some of the features that help make this happen:

- The Navigation window allows organization of the ladder logic programs used in your project and access to the functions, settings and configurations used to work with your project.
- The Instruction List window displays all available CLICK PLC instructions, allows you to drag and drop the instruction into your ladder logic program, and then enter any values and/or parameters required for the particular instruction.
- You can add Subroutine and Interrupt programs separately from the main ladder logic program. This allows you to manage your ladder logic programs in a simple, structured environment and, at the same time, aid in trouble-shooting your program.
- The Data View Monitor window configurations are saved with your project. This allows quick access to the same set of memory addresses that may have been set up for viewing during testing of your program.
- The graphical represented System Configuration dialog box allows checking the PLC system configuration. A Power Budget calculation feature is included. Refer to the Power Budgeting section later in this chapter for additional details.
- The Address Picker window allows quick selection of any memory address to be placed in the ladder logic program. Refer to the programming software online help for additional details.
- The PLC module Firmware can be updated from the programming software within 2 minutes.

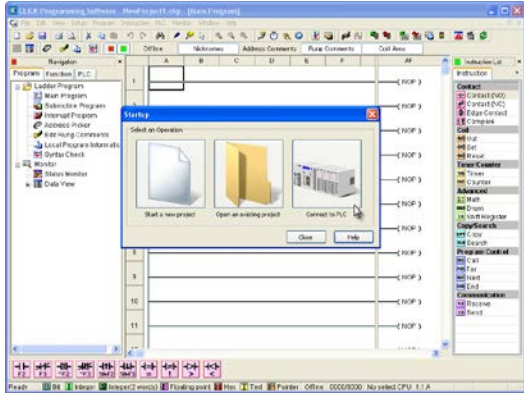

PC Requirements

Check our online webstore for current operating system requirements:







<http://www.automationdirect.com>

Data Types, Memory, and Numbering System

The following section explains how the CLICK PLC handles the available data types, memory addressing, and I/O numbering.

Data Types

The CLICK PLC supports the following data types. On the CLICK PLC programming software, each data type is indicated with a small icon.











| Data Type | S/W Icon | Data Ranges |
|-------------------------|---|---|
| Bit |  | 0, 1 |
| Integer (Single Word) |  | -32,768 to 32,767 |
| Integer2 (Double Word) |  | -2,147,483,648 to 2,147,483,647 |
| Floating Point |  | -3.4028235E+38 to 3.4028235E+38 |
| HEX (Hexadecimal) |  | 0000h to FFFFh (The HEX data type requires the 'h' after the value.) |
| Text (Single Character) |  | Single ASCII character (ASCII code: 00h to FFh.) |
| ASCII Code |  | ASCII code \$00 to \$FF (The ASCII Code data type requires the '\$' before the value.) |



NOTE: The CLICK PLC does not support Octal or BCD numbering systems (data types).

Memory Types

The following is the list of the memory types that the CLICK PLC system supports. See the memory map later in this chapter.

| Memory Type | Symbol | Data Type | S/W Icon | Definition |
|----------------------|--------|----------------|---|---|
| Input Point | X | Bit |  | The Discrete Input points are represented by the "X" symbol. |
| Output Point | Y | | | The Discrete Output points are represented by the "Y" symbol. |
| Control Relay | C | | | The Control Relay bits are represented by the "C" symbol. These internal bits are typically used for ladder program control. They do not represent any real world inputs or outputs. |
| Timer | T | | | The Timers are represented by the "T" symbol. The Timer status bit is used to indicate when the Current Value of the timer equals its Preset Value. |
| Counter | CT | | | The Counters are represented by the "CT" symbol. The Counter status bit is used to indicate when the Current Value of the counter equals its Preset Value. |
| System Control Relay | SC | | | The internal System Control Relays, represented by the "SC" symbol, are pre-defined bits which represent the status of specific system functions. |
| Data Register | DS | Integer |  | Single word integer data registers are represented by the "DS" symbol. |
| | DD | Integer2 |  | Double word integer data registers are represented by the "DD" symbol. |
| | DH | HEX |  | Single word Hex data registers are represented by the "DH" symbol. |
| | DF | Floating Point |  | Data Floating Point registers are IEEE format Real number values represented by the "DF" symbol as 32-bit words. |
| Input Register | XD | HEX |  | The Input Registers, represented by the "XD" symbol, contain groups of Discrete Input points in a 16-bit word format. XD0 is a Hexadecimal representation of X1-X16, XD1 of X101-X116, etc. |
| Output Register | YD | | | The Output Registers, represented by the "YD" symbol, contain groups of Discrete Output points in a 16-bit word format. YD0 is a Hexadecimal representation of Y1-Y16, YD1 of Y101-Y116, etc. |
| Timer Register | TD | Integer |  | The Timer Registers, represented by the "TD" symbol, contain the corresponding Timer's accumulative value in a 16-bit data register. |
| Counter Register | CTD | Integer2 |  | The Counter Registers, represented by the "CTD" symbol, contain the corresponding Counter's accumulative value in a 32-bit data register. |
| System Data Register | SD | Integer |  | The internal System Data Registers, represented by the "SD" symbol, are pre-defined words which represent the status of specific system functions. |
| Text | TXT | Text |  | The Text data registers, represented by the "TXT" symbol, are used to store and manipulate ASCII text data. |

Memory Types (cont'd)

Pointer Addressing

The CLICK PLC allows the use of Pointer Addressing for flexibility in programming. The Copy instruction supports Pointer Addressing in the single copy mode. The Pointer is always assigned as a DS memory type and is designated as a Pointer by placing the DS memory type in square brackets, such as [DS1]. Pointer Addressing uses the Pointer's data value to point to a memory location within the range of one of the eligible memory types. Pointer Addressing can be used with the DS, DD, DF, DH, XD, YD, TD, CTD and TXT data register memory types.

Pointer Addressing is also sometimes referred to as Indirect Addressing. One of the many uses for Pointer Addressing would be to perform lookup in tables. An application example might be determining the number of gallons in a horizontal tank when the liquid level is known. The gallons could be determined by a rather complex math formula, but a simpler approach would be to pre-calculate the number of gallons at several uniform levels, and place these values into a table of data registers that can be accessed using Pointer Addressing.

Pointer Addressing Example

DS1 = 100; data register DS1 is assigned the value of 100.

Then the use of DD[DS1] would be the same as showing DD100.

As the value in DS1 is changed, the result would then point to a different DD data register.

In the example, data register DS1 is called a Pointer. Only a DS memory type can be used as a pointer. As mentioned before, the use of the [square brackets] around DS1 in the data register reference DD[DS1] is how the Pointer Addressing is designated.

I/O Numbering System

The CLICK PLC uses decimal numbers for the input (X) and output (Y) addressing.

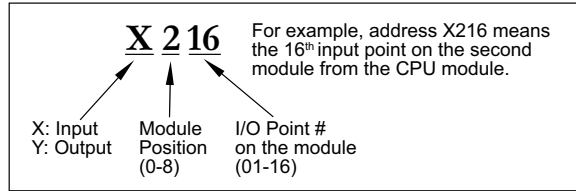

Module Location

Please refer to the following diagram to understand the module position and I/O numbering.

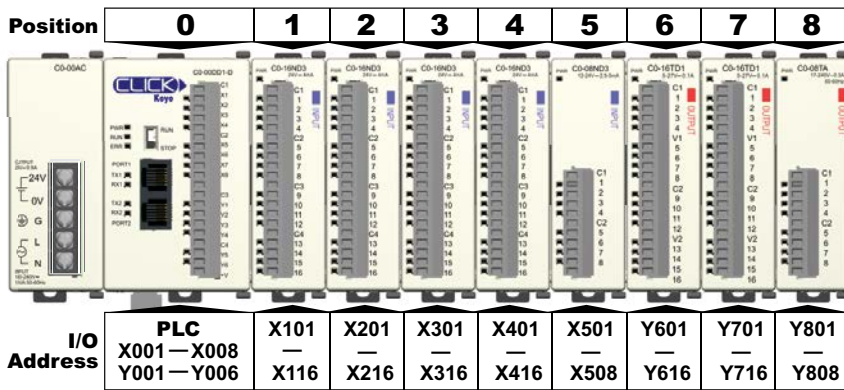

Addressing can be checked by using the System Configuration window from within the CLICK programming software. From the Setup pulldown menu, select System Configuration; otherwise, from the Navigation window select the Function tab, and under PLC configuration, double click on System Configuration.

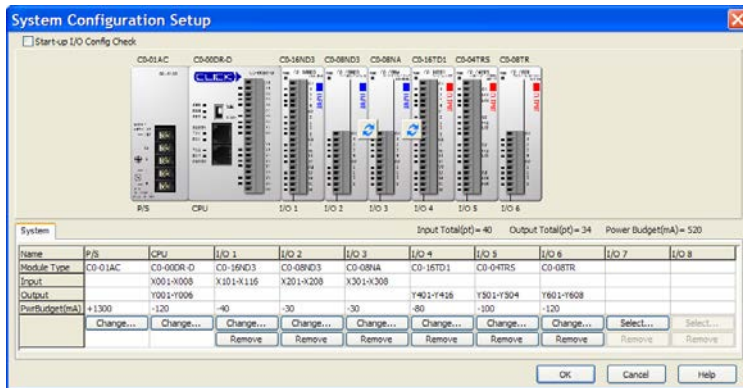

PLC Operation

Introduction

Achieving proper control of your equipment or process requires a thorough understanding of how the CLICK PLC controls all aspects of system operation. There are three main areas to understand before you create your application program:

- PLC Operating System – the PLC manages all aspects of system control. A quick overview of all the steps are provided in the next section.
- PLC Operating Modes – The two primary modes of operation are Stop mode and Run mode.
- PLC Memory Map – CLICK PLCs offer a wide variety of resources, such as timers, counters, inputs, etc. The Memory Map section shows the organization and availability of these data types.

PLC Operating System

At powerup, the CLICK PLC initializes the internal electronic hardware. Memory initialization starts with examining the retentive memory settings. In general, the contents of retentive memory are preserved, and non-retentive memory is initialized to zero (unless otherwise specified).

After the one-time powerup tasks, the PLC begins the cyclical scan activity. The flowchart to the right shows how the tasks differ, based on the PLC mode and the existence of any errors. The “scan time” is defined as the average time around the task loop. Note that the PLC is always reading the inputs, even during Stop mode. This allows programming tools to monitor input status at any time.

The outputs are only updated in Run mode. In Stop mode, they are in the off state.

Error detection has two levels. Non-fatal errors are reported, but the PLC remains in its current mode. If a fatal error occurs, the PLC is forced into Stop mode and the outputs turn off.

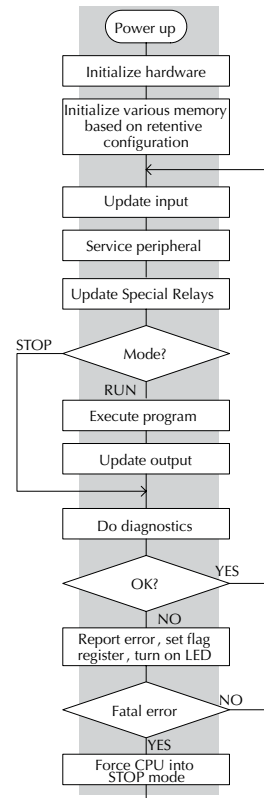

PLC Operating Modes

Stop Mode

In Stop mode, the CLICK PLC does NOT execute the ladder logic program or update the output points. The primary use for Stop Mode is to enter or change a ladder logic program. You also use Stop mode to set up the PLC parameters, such as retentive memory areas, etc.

You can use CLICK Programming Software, or the CLICK PLC mode switch to place the PLC in Stop mode; however, the CLICK PLC mode switch will override the software mode condition. If the PLC mode switch is in the Stop position, the software is blocked from changing the PLC mode. When the PLC mode switch is in the Run position, the software may toggle the mode switch from Run to Stop at will.

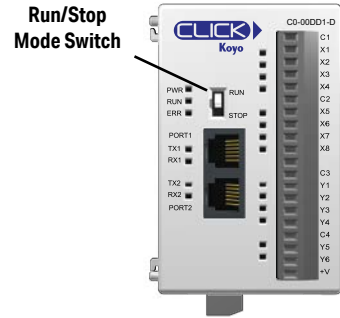

Run Mode

In Run mode, the PLC executes the application program and updates the I/O system. You can perform many operations during Run mode. Some of these include:

- Monitor and change I/O point status
- Change timer/counter preset values
- Change variable memory locations

The Run Mode can be divided into several key areas. For the vast majority of applications, some of these execution segments are more important than others. For example, you need to understand how the PLC updates the I/O points, handles forcing operations, and solves the application program. The remaining segments are not that important for most applications.

You can use CLICK Programming Software, or the CLICK PLC mode switch to place the PLC in Run mode.

Normal Run Mode Scan

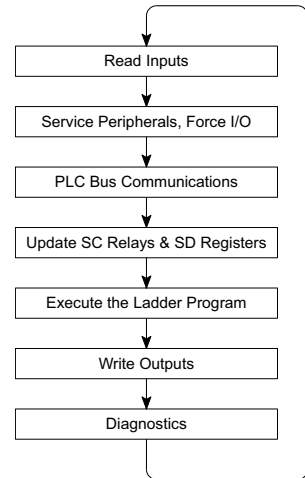

WARNING: Only authorized personnel fully familiar with all aspects of the application should make changes to the ladder logic program. Make sure you thoroughly consider the impact of any changes to minimize the risk of personal injury or damage to equipment.

Read Inputs

The CLICK PLC reads the status of all inputs, then stores it in the image register. Input image register locations are designated with an X followed by a memory location. Image register data is used by the PLC when it solves the application program.

Of course, an input may change after the PLC has just read the inputs. Generally, the PLC scan time is measured in milliseconds. If you have an application that cannot wait until the next I/O update, you can use Immediate Instructions. These do not use the status of the input image register to solve the application program. The Immediate instructions immediately read the input status directly from the I/O modules. However, this lengthens the program scan since the PLC has to read the I/O point status again.

Service Peripherals and Force I/O

After the CLICK PLC reads the inputs from the input modules, it reads any attached peripheral devices. This is primarily a communications service for any attached devices. For example, it would read a programming device to see if any input, output, or other memory type status needs to be modified. There are two basic types of forcing available with the CLICK PLC:

- Forcing from a peripheral – not a permanent force, good only for one scan
- Bit Override – holds the I/O point (or other bit) in the current state. Valid bits are X, Y, C, T and CT. (These memory types are discussed in more detail earlier in this chapter).

Forcing and Bit Override are done through the Data View Monitor.

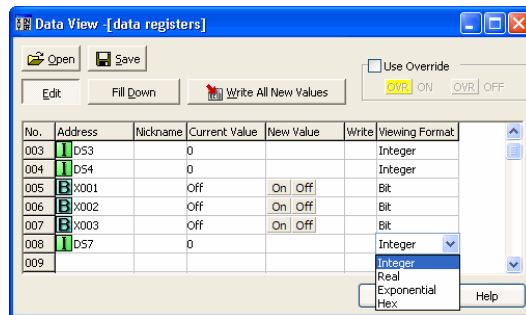

Regular Forcing: This type of forcing can temporarily change the status of a discrete bit. For example, you may want to force an input on, even though it is really off. This allows you to change the point status that was stored in the image register. This value will be valid until the image register location is written to during the next scan. This is primarily useful during testing situations when you need to force a bit on to trigger another event.

Bit override: This is a more forceful type of bit manipulation. When bit override is enabled, you can actually override the current status of a bit in the image register. This change will remain intact until you remove the override.



WARNING: Only authorized personnel fully familiar with all aspects of the application should make changes to the program. Make sure you thoroughly consider the impact of any changes to minimize the risk of personal injury or damage to equipment.

Update System Control (SC) Relays and System Data (SD) Registers

The CLICK PLC units have system memory locations that hold this information. This portion of the execution cycle ensures these locations get updated on every scan. Also, there are several different system control relays, such as diagnostic relays, etc., that are also updated during this segment.

Solve Application Program

The CLICK PLC evaluates each instruction in the application program during this segment of the scan cycle. The instructions define the relationship between the input conditions and the desired output response. The CLICK PLC uses the output image register area to store the status of the desired action for the outputs. Output image register locations are designated with a Y followed by a memory location. The actual outputs are updated during the write outputs segment of the scan cycle.

The internal control relays (C) and the data registers (DS, DD, DF and DH) are also updated in this segment.

You may recall that you can force various types of points in the system, discussed earlier in this chapter. If any I/O points or memory data have been forced, the output image register also contains this information.

Write Outputs

Once the application program has solved the instruction logic and constructed the output image register, the CLICK PLC writes the contents of the output image register to the corresponding output points. Remember, the PLC also ensured that any forcing operation changes were stored in the output image register, so the forced points get updated with the status specified earlier.

Diagnostics

During this part of the scan, the PLC performs all system diagnostics and other tasks such as calculating the scan time and resetting the watchdog timer. There are many different error conditions that are automatically detected and reported by the CLICK PLC. Chapter 6: *Troubleshooting* contains a listing of the various error codes with a description of the possible causes.

Probably one of the more important things that occurs during this segment is the scan time calculation and watchdog timer control. The CLICK PLC has a watchdog timer that stores the maximum time allowed for the PLC to complete the solve application part of the scan cycle. If this time is exceeded, the PLC will enter the Stop mode and turn off all outputs. An error is automatically reported. The default value of the watchdog timer is 200ms and can be adjusted between 5–10,000 ms. Refer to the online help available from the CLICK Programming Software, C0-PGMSW, for additional information in regards to the Watchdog Timer.

Power Budgeting

What is Power Budgeting?

There are two areas that need to be considered when determining the power required to operate a CLICK PLC system. The first area is the power required by the CLICK PLC, along with the internal logic side power that the PLC provides to its own I/O and any connected I/O modules that are powered through the PLC expansion port, plus any device, such as a C-more Micro-Graphic panel, that is powered through one of the PLC's communication ports.

The second area is the power required by all externally connected I/O devices. This should be viewed as the field side power required. The field side power is dependent on the voltage used for a particular input or output device as it relates to the wired I/O point, and the calculated load rating of the connected device

It is strongly recommended that the power source for the logic side be separate from the power source for the field side to help eliminate possible electrical noise.

Be aware that the CLICK PLC unit sinking DC output points require a sustained voltage to work with their output drivers. This includes the C0-00DD1-D PLC, and the C0-08TD1 & C0-16TD1 output modules. It is recommended that this voltage be provided from the field side power source.

The CLICK PLC operates from a 24VDC power source. The 24VDC power source can be provided by an optional CLICK PLC unit power supply (C0-00AC or C0-01AC), or a standard industrial 24VDC power supply as offered by AutomationDirect.



CLICK 24VDC Power Supply
C0-00AC or C0-01AC



Alternative 24VDC Power Supply
Example: PSP24-DC12-1

Visit www.automationdirect.com for the complete line.

The power source for the connected I/O devices is dependent on the voltage rating of the devices and the type of CLICK I/O module that is being used.

Power Budgeting requires the calculation of the total current that the 24VDC power source needs to provide to CLICK PLC unit logic side, and also a separate calculation of the total current required from all devices operating from the field side of the CLICK PLC system.

Refer to the following pages which includes tables listing the CLICK PLC and I/O module current requirements, plus a power budgeting example.

Power Budget Calculation

The following table shows the current consumption required for both the logic side and field side of the CLICK units.

| PLC Current Consumption (mA) | | |
|------------------------------------|---------------------------------------|-----------------------------------|
| Part Number | Power Budget 24VDC (logic side) | External 24VDC (field side) |
| Basic PLC Units | | |
| C0-00DD1-D | 120 | 60 |
| C0-00DD2-D | 120 | 0 |
| C0-00DR-D | 120 | 0 |
| C0-00AR-D | 120 | 0 |
| Standard PLC Units | | |
| C0-01DD1-D | 140 | 60 |
| C0-01DD2-D | 140 | 0 |
| C0-01DR-D | 140 | 0 |
| C0-01AR-D | 140 | 0 |
| Analog PLC Units | | |
| C0-02DD1-D | 140 | 60 |
| C0-02DD2-D | 140 | 0 |
| C0-02DR-D | 140 | 0 |
| Ethernet Basic PLC Units | | |
| C0-10DD1E-D | 120 | 60 |
| C0-10DD2E-D | 120 | 0 |
| C0-10DRE-D | 120 | 0 |
| C0-10ARE-D | 120 | 0 |
| Ethernet Standard PLC Units | | |
| C0-11DD1E-D | 140 | 60 |
| C0-11DD2E-D | 140 | 0 |
| C0-11DRE-D | 140 | 0 |
| C0-11ARE-D | 140 | 0 |
| Ethernet Analog PLC Units | | |
| C0-12DD1E-D | 140 | 60 |
| C0-12DD2E-D | 140 | 0 |
| C0-12DRE-D | 160 | 0 |
| C0-12ARE-D | 160 | 0 |
| C0-12DD1E-1-D | 140 | 60 |
| C0-12DD2E-1-D | 140 | 0 |
| C0-12DRE-1-D | 160 | 0 |
| C0-12ARE-1-D | 160 | 0 |
| C0-12DD1E-2-D | 140 | 60 |
| C0-12DD2E-2-D | 140 | 0 |
| C0-12DRE-2-D | 160 | 0 |
| C0-12ARE-2-D | 140 | 0 |

| I/O Module Current Consumption (mA) | | |
|---|---------------------------------------|-----------------------------------|
| Part Number | Power Budget 24VDC (logic side) | External 24VDC (field side) |
| Discrete Input Modules | | |
| C0-08ND3 | 30 | 0 |
| C0-08ND3-1 | 30 | 0 |
| C0-16ND3 | 40 | 0 |
| C0-08NE3 | 30 | 0 |
| C0-16NE3 | 40 | 0 |
| C0-08NA | 30 | 0 |
| Discrete Output Modules | | |
| C0-08TD1 | 50 | 15 |
| C0-08TD2 | 50 | 0 |
| C0-16TD1 | 80 | 100 |
| C0-16TD2 | 80 | 0 |
| C0-08TA | 80 | 0 |
| C0-04TRS | 100 | 0 |
| C0-04TRS-10 | 120 | 0 |
| C0-08TR | 100 | 0 |
| C0-08TR-3 | 90 | 0 |
| Discrete Combo I/O Modules | | |
| C0-16CDD1 | 80 | 50 |
| C0-16CDD2 | 80 | 0 |
| C0-08CDR | 80 | 0 |
| Specialty Modules | | |
| C0-08SIM | 50 | 0 |
| Analog Input Modules | | |
| C0-04AD-1 | 20 | 65 |
| C0-04AD-2 | 23 | 65 |
| C0-04RTD | 25 | 0 |
| C0-04THM | 25 | 0 |
| Analog Output Modules | | |
| C0-04DA-1 | 20 | 145 |
| C0-04DA-2 | 20 | 85 |
| Analog Combo I/O Modules | | |
| C0-4AD2DA-1 | 25 | 75 |
| C0-4AD2DA-2 | 20 | 65 |
| C-more Micro-Graphic Panel (Monochrome only) | | |
| All p/n | 90 | 0 |

Power Budget Example

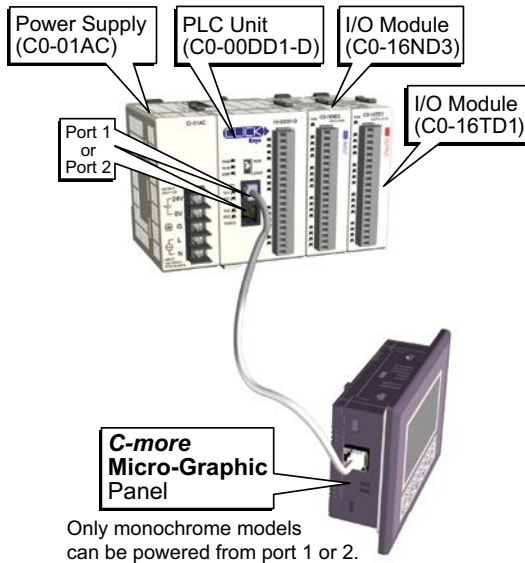

Add the current consumption for each module in the system as shown in this example.

| Current Consumption (mA) | | |
|--------------------------|---------------------------------|-----------------------------|
| Part Number | Power Budget 24VDC (logic side) | External 24VDC (field side) |
| C0-00DD1-D | 120 | 60 |
| C0-16ND3 | 40 | 0 |
| C0-16TD1 | 80 | 100 |
| C-more Micro | 90 | 0 |
| Total: | 330 | 160* |

* Plus calculated load of connected I/O devices.

Power Budgeting using the CLICK Programming Software

The following example shows the logic side current consumption as calculated in the System Configuration Setup section of the CLICK Programming Software. Based on the amperage rating of the power supply selected in the first column, your power budget is calculated by subtracting each consecutive module's power consumption from the total available power budget. If you exceed the maximum allowable power consumption, the power budget row fills in red.

Power budget row turns red if maximum allowable power consumption is exceeded for the power supply selected.

| Name | P/S | CPU | I/O 1 | I/O 2 | I/O 3 | I/O 4 | I/O 5 | I/O 6 | I/O 7 | I/O 8 |
|-----------------|---------|------------|-----------|-----------|-----------|-----------|-----------|-----------|-------|-------|
| Module Type | C0-01AC | C0-01DD2-D | C0-08ND3 | C0-08NE3 | C0-16NE3 | C0-16TD1 | C0-04TR5 | C0-08TR | | |
| Input(Y) | | X001-X008 | X101-X108 | X201-X208 | X301-X316 | | | | | |
| Output(Y) | | Y001-Y006 | | | | Y401-Y416 | Y501-Y504 | Y601-Y604 | | |
| PowerBudget(mA) | +1200 | -140 | -30 | -30 | -40 | -80 | -100 | -100 | | |

General Specifications

General Specifications (all CLICK PLC units)

The following general specifications apply to all CLICK PLC units, optional I/O modules, and optional power supply products. Please refer to the appropriate I/O temperature derating charts under both the PLC and I/O module specifications to determine best operating conditions based on the ambient temperature of your particular application.

| General Specifications | |
|---------------------------------------|--|
| Power Input Voltage Range | 20–28 VDC |
| Maximum Power Consumption | 5W (No 5V use from communication port) |
| Maximum Inrush Current | 30A (less than 1ms) |
| Acceptable External Power Drop | Max 10ms |
| Operating Temperature | Analog units, analog combo I/O modules only: 32°F to 140°F (0°C to 60°C); All other modules: 32°F to 131°F (0°C to 55°C), IEC 60068-2-14 (Test Nb, Thermal Shock) |
| Storage Temperature | –4°F to 158°F (–20°C to 70°C) IEC 60068-2-1 (Test Ab, Cold) IEC 60068-2-2 (Test Bb, Dry Heat) IEC 60068-2-14 (Test Na, Thermal Shock) |
| Ambient Humidity | 30% to 95% relative humidity (non-condensing) |
| Environmental Air | No corrosive gases The level for the environmental pollution is 2 (UL840) |
| Vibration | MIL STD 810C, Method 514.2 IEC60068-2-27, Category [f], Procedure[VIII] JIS C60068-2-27 (Sine wave vibration test) |
| Shock | MIL STD 810C, Method 516.2 IEC60068-2-27 JIS C60068-2-27, Category [f], Procedure[VIII] |
| Noise Immunity | <EN61131-2> EN61000-4-2 (ESD) EN61000-4-3 (RFI) EN61000-4-4 (FTB) EN61000-4-5 (Surge) EN61000-4-6 (Conducted) EN61000-4-8 (Power frequency magnetic field immunity) Comply with NEMA ICS3-304 Impulse noise 1µs, 1000V RFI: No interference measured at 150MHz and 450MHz (5w/15cm) |
| Emissions | EN55011:1998 Class A; EN61000-6-4:2007+A1:2011 |
| Agency Approvals | UL508 (File No. E157382, E316037); CE (EN61131-2); CUL Canadian C22.2 |
| Other | RoHS 2011/65/EU Amendment (EU)2015/863 |

PLC Unit Specifications

Common Specifications

| Basic, Standard and Analog PLC Unit Specifications | | | |
|--|---|--|--|
| | Basic PLC | Standard PLC | Analog PLC |
| Control Method | Stored Program/Cyclic execution method | Stored Program/Cyclic execution method | Stored Program/Cyclic execution method |
| I/O Numbering System | Fixed in Decimal | Fixed in Decimal | Fixed in Decimal |
| Ladder Memory (steps) | 8000 | 8000 | 8000 |
| Total Data Memory (words) | 8000 | 8000 | 8000 |
| Contact Execution (boolean) | < 0.6us | < 0.6us | < 0.6us |
| Typical Scan (1k boolean) | 1–2 ms | 1–2 ms | 1–2 ms |
| RLL Ladder Style Programming | Yes | Yes | Yes |
| Run Time Edits | No | No | No |
| Scan | Variable / fixed | Variable / fixed | Variable / fixed |
| CLICK Programming Software for Windows | Yes | Yes | Yes |
| Built-in Communication Ports | Yes (two RS-232 ports) | Yes (two RS-232 ports and one RS-485 port) | Yes (two RS-232 ports and one RS-485 port) |
| FLASH Memory | Standard on PLC | Standard on PLC | Standard on PLC |
| Protocol | Protocols: Modbus RTU (master/slave) and ASCII (in/out) | | |
| Built-in Discrete I/O points | 8 inputs, 6 outputs | 8 inputs, 6 outputs | 4 inputs, 4 outputs |
| Built-in Analog I/O Channels | No | No | 2 inputs, 2 outputs |
| Number of Instructions Available | 21 | 21 | 21 |
| Control Relays | 2000 | 2000 | 2000 |
| System Control Relays | 1000 | 1000 | 1000 |
| Timers | 500 | 500 | 500 |
| Counters | 250 | 250 | 250 |
| Interrupt | Yes (external: 8 / timed: 4) | Yes (external: 8 / timed: 4) | Yes (external: 4 / timed: 4) |
| Subroutines | Yes | Yes | Yes |
| For/Next Loops | Yes | Yes | Yes |
| Math (Integer and Hex) | Yes | Yes | Yes |
| Drum Sequencer Instruction | Yes | Yes | Yes |
| Internal Diagnostics | Yes | Yes | Yes |
| Password Security | Yes | Yes | Yes |
| System Error Log | Yes | Yes | Yes |
| User Error Log | No | No | No |
| Memory Backup | Super Capacitor | Super Capacitor + Battery | Super Capacitor + Battery |
| Battery Backup | No | Yes (battery part # D2-BAT-1) | Yes (battery part # D2-BAT-1) |
| Calendar/Clock | No | Yes | Yes |
| I/O Terminal Block Replacement | AutomationDirect p/n C0-16TB | AutomationDirect p/n C0-16TB | AutomationDirect p/n C0-16TB |
| Communication Port & Terminal Block Replacement | N/A | AutomationDirect p/n C0-3TB | AutomationDirect p/n C0-3TB |
| 24VDC Power Terminal Block Replacement | AutomationDirect p/n C0-4TB | AutomationDirect p/n C0-4TB | AutomationDirect p/n C0-4TB |

PLC Unit Specifications, cont'd

| Ethernet Basic, Standard and Analog PLC Unit Specifications | | | |
|---|--|--|--|
| | Ethernet Basic PLC | Ethernet Standard PLC | Ethernet Analog PLC |
| Control Method | Stored Program/Cyclic Execution Method | | |
| I/O Numbering System | Fixed in Decimal | Fixed in Decimal | Fixed in Decimal |
| Ladder Memory (steps) | 8000 | 8000 | 8000 |
| Total Data Memory (words) | 8000 | 8000 | 8000 |
| Contact Execution (Boolean) | < 0.2 μ s | < 0.2 μ s | < 0.2 μ s |
| Typical Scan (1K Boolean) | < 1ms | < 1ms | < 1ms |
| RLL Ladder Style Programming | Yes | Yes | Yes |
| Run Time Edits | Yes | Yes | Yes |
| Scan | Variable / fixed | Variable / fixed | Variable / fixed |
| CLICK Programming Software for Windows | Yes | Yes | Yes |
| Built-in Communication Ports | Yes (one Ethernet port and one RS-232 port) | Yes (one Ethernet port, one RS-232 port and one RS-485 port) | Yes (one Ethernet port, one RS-232 port and one RS-485 port) |
| Protocol | Modbus RTU (master/slave) and ASCII (in/out), Modbus TCP (client server), EtherNet/IP Implicit and Explicit (adapter server) | | |
| FLASH Memory | Standard on PLC | Standard on PLC | Standard on PLC |
| Built-in Discrete I/O points | 8 inputs, 6 outputs | 8 inputs, 6 outputs | 4 inputs, 4 outputs |
| Built-in Analog I/O Channels | No | No | 2 inputs, 2 outputs or 4 inputs, 2 outputs |
| Number of High-Speed Input Points | 4 | 8 | 4 |
| Number of High-Speed Counters | 4 | 6 | 4 |
| PID Control Loops | 8 | 8 | 8 |
| Number of Instructions Available | 21 | 21 | 21 |
| Control Relays | 2000 | 2000 | 2000 |
| System Control Relays | 1000 | 1000 | 1000 |
| Timers | 500 | 500 | 500 |
| Counters | 250 | 250 | 250 |
| Interrupts | Yes (external: 8 / timed: 4) | Yes (external: 8 / timed: 4) | Yes (external: 4 / timed: 4) |
| Subroutines | Yes | Yes | Yes |
| For/Next Loops | Yes | Yes | Yes |
| Math (Integer and Hex) | Yes | Yes | Yes |
| Drum Sequencer Instruction | Yes | Yes | Yes |
| Internal Diagnostics | Yes | Yes | Yes |
| Password Security | Yes | Yes | Yes |
| System Error Log | Yes | Yes | Yes |
| User Error Log | No | No | No |
| Memory Backup | Super Capacitor + Battery | | |
| Battery Backup | Yes (battery part # D2-BAT-1) | | |
| Calendar/Clock | Yes | Yes | Yes |
| I/O Terminal Block Replacement | AutomationDirect p/n C0-16TB | | |
| Communication Port & Terminal Block Replacement | N/A | AutomationDirect p/n C0-3TB | AutomationDirect p/n C0-3TB |
| 24VDC Power Terminal Block Replacement | AutomationDirect p/n C0-4TB | | |

PLC LED Status Indicators

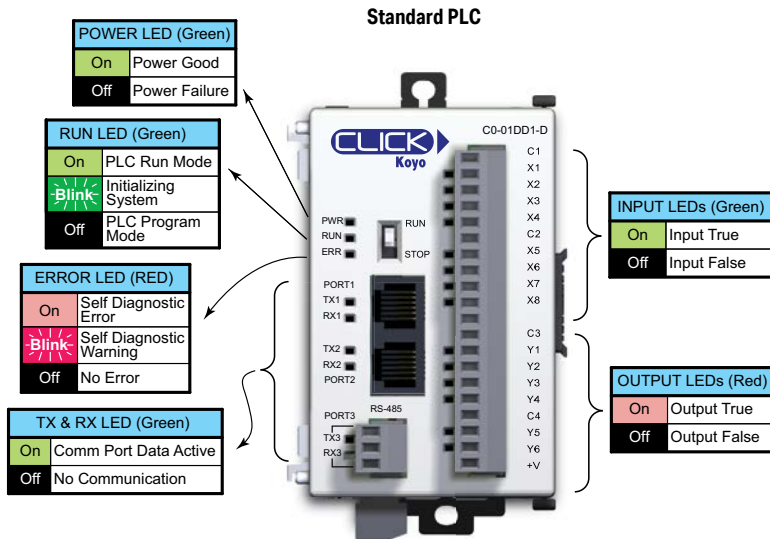
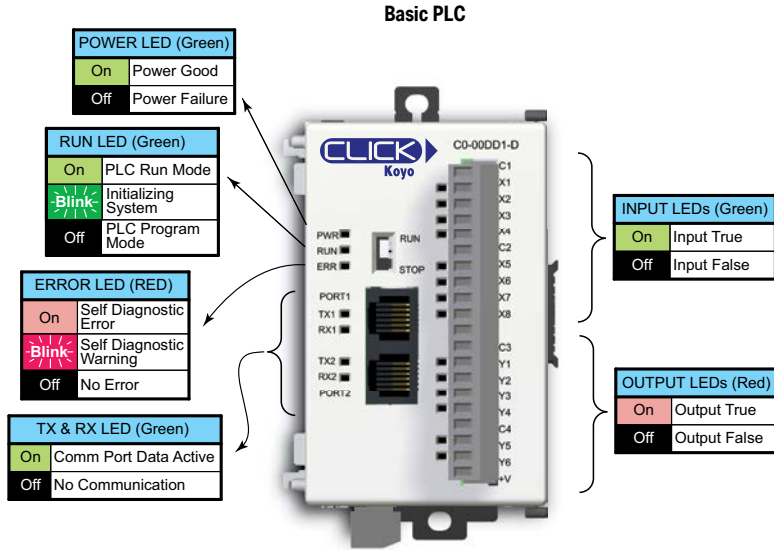

PLC LED Status Indicators, (cont'd)

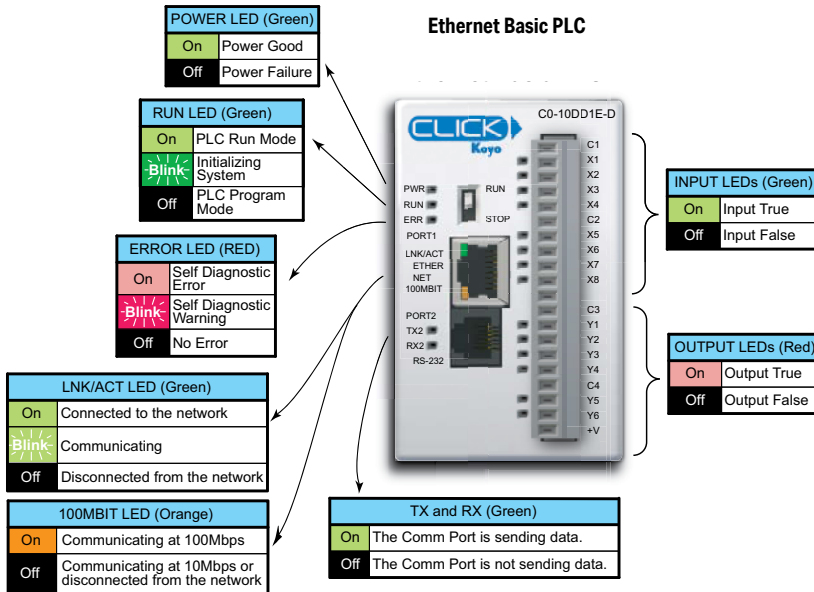
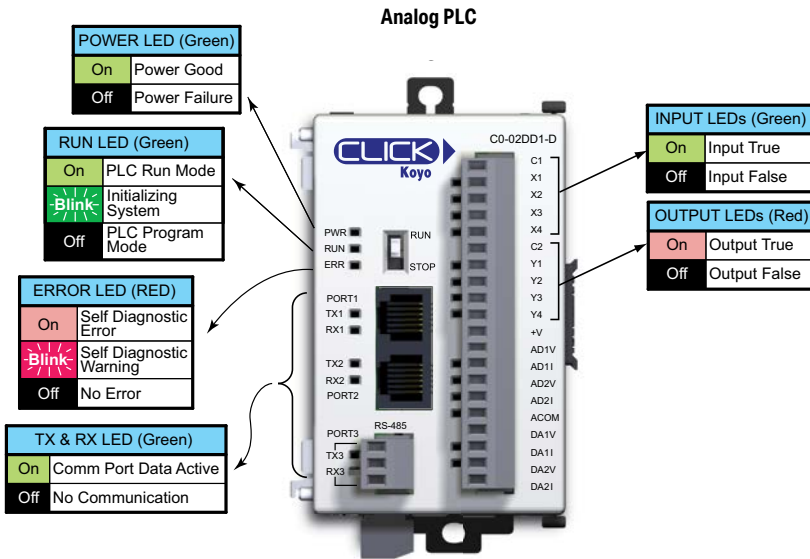

PLC LED Status Indicators, (cont'd)

Ethernet Standard PLC

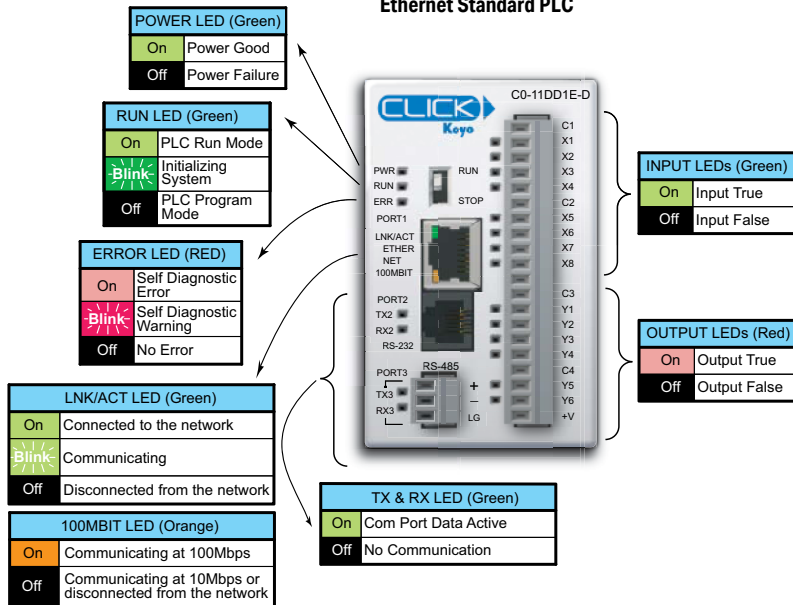



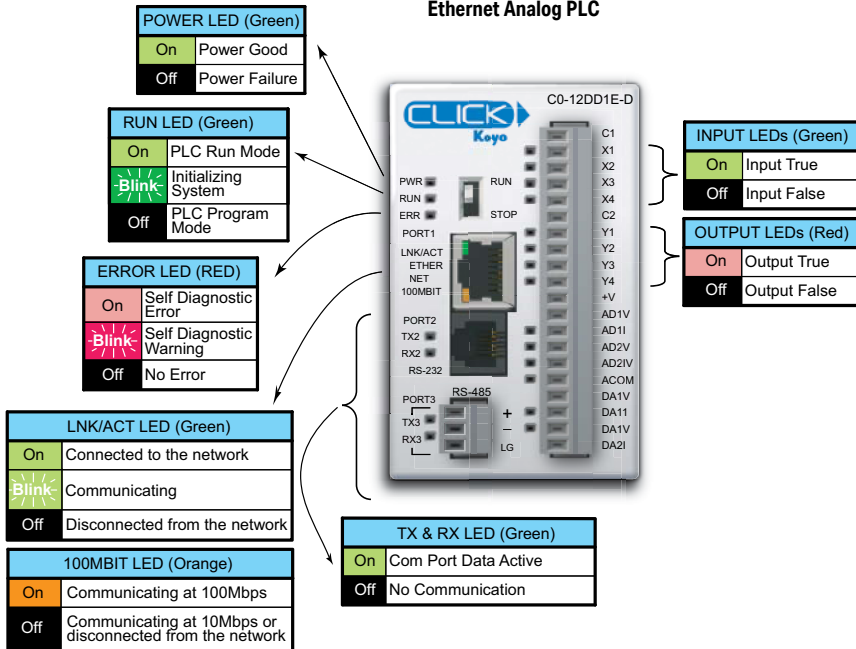







Ethernet Analog PLC



Memory Map

All of the CLICK PLC units support the same memory map. The CLICK PLC uses decimal numbers for the memory addressing. See pages 2-15 and 2-16 for the definitions of each data type and memory type.

| Memory Type | Symbol | Data Type | S/W Icon | Range |
|----------------------|--------|----------------|---|----------------|
| Input Point | X | Bit |  | X001 – X816 |
| Output Point | Y | | | Y001 – Y816 |
| Control Relay | C | | | C1 – C2000 |
| Timer | T | | | T1 – T500 |
| Counter | CT | | | CT1 – CT250 |
| System Control Bit | SC | | | SC1 – SC1000 |
| Data Register | DS | Integer |  | DS1 – DS4500 |
| | DD | Integer2 |  | DD1 – DD1000 |
| | DH | HEX |  | DH1 – DH500 |
| | DF | Floating Point |  | DF1 – DF500 |
| Input Register | XD | HEX |  | XD0 – XD8 |
| Output Register | YD | | | YD0 – YD8 |
| Timer Register | TD | Integer |  | TD1 – TD500 |
| Counter Register | CTD | Integer2 |  | CTD1 – CTD250 |
| System Data Register | SD | Integer |  | SD1 – SD1000 |
| Text | TXT | Text |  | TXT1 – TXT1000 |

CLICK Software PID Specifications

| PID Specifications | |
|------------------------------------|---|
| PID maximum number of loops | 8 |
| Required Memory | 40 C bits, 15 DS registers, 25 DF registers |
| Control Algorithm | Position |
| Control Loop Action | Direct-acting or Reverse-acting |
| Error Term | Linear or Squared |
| Error Dead band | Configurable |
| Proportional Gain | 0.01–10000 |
| Reset Time (Integral) | 0.01–6000 |
| Derivative Gain | 0.0–6000 |
| Sampling rate | 100ms to 30000ms |
| Loop Calculation | PID or PI |
| PV Filter | Configurable |
| Set Point | Maximum and minimum values can be set |
| Control Output | Maximum and minimum values can be set |
| Derivative Gain Limit | Configurable |
| Bias Freeze (Anti-Windup) | Yes |
| Bumpless Transfer | 2 Modes |
| Pulse Width Modulation (PWM)Output | Yes, up to 600 second period |
| Auto Tuning | Ziegler-Nichols Limit Cycle |
| Alarms | |
| PV Alarm | PV alarm value can be set at Low-low, Low, High, High-high condition |
| Deviation Alarm | Specify alarms for two ranges of PV deviation from the setpoint value |
| PV Rate of Change | Detect when PV exceeds a rate of change limit you specify |

CLICK PLC Hardware/Software Compatibility

The table below shows the most recent software and hardware versions required for each hardware and feature release

| CLICK PLC Features Software Compatibility | | | | | | |
|---|----------------------------------|--------------------------------|-------------------|-------------|-------|-------------|
| CPU Type | Part Number | Minimum CLICK Software Version | | | | |
| | | Hardware | High-Speed Inputs | EtherNet/IP | PID | I/O Modules |
| Basic | C0-00DD1-D | v1.00 | N/A | N/A | N/A | N/A |
| | C0-00DD2-D | | | | | |
| | C0-00DR-D | | | | | |
| | C0-00AR-D | | | | | |
| Standard | C0-01DD1-D | v1.20 | N/A | N/A | N/A | N/A |
| | C0-01DD2-D | | | | | |
| | C0-01DR-D | | | | | |
| | C0-01AR-D | | | | | |
| Analog | C0-02DD1-D (before SN 171208001) | v1.12 | N/A | N/A | N/A | N/A |
| | C0-02DD1-D (after SN 171208001) | v2.10 | | | | |
| | C0-02DD2-D (before SN 174018001) | v1.12 | | | | |
| | C0-02DD2-D (after SN 174018001) | v2.10 | | | | |
| | C0-02DR-D (before SN 173158001) | v1.12 | | | | |
| | C0-02DR-D (after SN 173158001) | v2.10 | | | | |
| Ethernet Basic | C0-10DD1E-D | v2.00 | v2.30 | v2.40 | v2.50 | N/A |
| | C0-10DD2E-D | | | | | |
| | C0-10DRE-D | | N/A | | | |
| | C0-10ARE-D | | | | | |
| Ethernet Standard | C0-11DD1E-D | v2.00 | v2.30 | v2.40 | v2.50 | N/A |
| | C0-11DD2E-D | | | | | |
| | C0-11DRE-D | | N/A | | | |
| | C0-11ARE-D | | | | | |
| Ethernet Analog | C0-12DD1E-D | v2.20 | v2.30 | v2.40 | v2.50 | N/A |
| | C0-12DD2E-D | | | | | |
| | C0-12DRE-D | | N/A | | | |
| | C0-12ARE-D | | | | | |
| | C0-12DD1E-1-D | | v2.30 | | | |
| | C0-12DD2E-1-D | | | | | |
| | C0-12DRE-1-D | | N/A | | | |
| | C0-12ARE-1-D | | | | | |
| | C0-12DD1E-2-D | | v2.30 | | | |
| | C0-12DD2E-2-D | | | | | |
| | C0-12DRE-2-D | | N/A | | | |
| | C0-12ARE-2-D | | | | | |

CLICK PLC Hardware/Software Compatibility (continued)

| CLICK PLC Features Software Compatibility | | | | | | |
|---|-------------|--------------------------------|-------------------|-------------|-----|-------------|
| | | Minimum CLICK Software Version | | | | |
| | Part Number | Hardware | High-Speed Inputs | EtherNet/IP | PID | I/O Modules |
| Relay Modules | C0-04TRS-10 | N/A | N/A | N/A | N/A | v2.60 |
| | C0-08TR-3 | | | | | |
| Simulator Module | C0-08SIM | | | | | |

Basic PLC Unit Specifications

C0-00DD1-D – 8 DC Input/6 Sinking DC Output Micro PLC

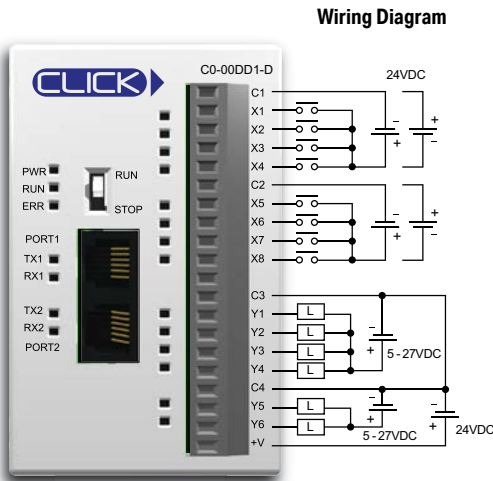

| Built-in I/O Specifications - Inputs | |
|--------------------------------------|--|
| Inputs per Module | 8 (Sink/Source) |
| Operating Voltage Range | 24VDC |
| Input Voltage Range | 21.6-26.4 VDC |
| Input Current | X1-2: Typ 5mA @ 24VDC X3-8: Typ 4mA @ 24VDC |
| Maximum Input Current | X1-2: 6.0 mA @ 26.4 VDC X3-8: 5.0 mA @ 26.4 VDC |
| Input Impedance | X1-2: 4.7 kΩ @ 24VDC X3-8: 6.8 kΩ @ 24VDC |
| ON Voltage Level | X1-2: > 19VDC X3-8: > 19VDC |
| OFF Voltage Level | X1-2: < 4VDC X3-8: < 7VDC |
| Minimum ON Current | X1-2: 4.5 mA X3-8: 3.5 mA |
| Maximum OFF Current | X1-2: 0.1 mA X3-8: 0.5 mA |
| OFF to ON Response | X1-2: Typ 5μs Max 20μs X3-8: Typ 2ms Max 10ms |
| ON to OFF Response | X1-2: Typ 5μs Max 20μs X3-8: Typ 3ms Max 10ms |
| Status Indicators | Logic Side (8 points, green LED) |
| Commons | 2 (4 points/common) Isolated |

| General Specifications | |
|-------------------------------------|---------------|
| Current Consumption at 24VDC | 120mA |
| Terminal Block Replacement Part No. | C0-16TB |
| Weight | 5.0 oz (140g) |

Equivalent Input Circuit

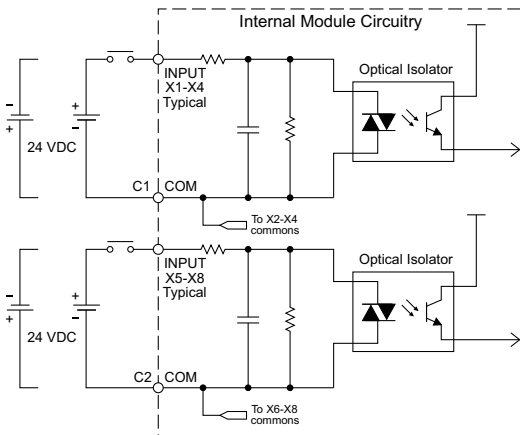

C0-00DD1-D Temperature Derating Chart

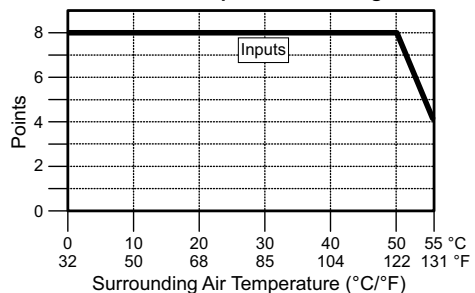

C0-00DD1-D – 8 DC Input/6 Sinking DC Output Micro PLC (continued)

| Built-in I/O Specifications - Outputs | |
|---------------------------------------|---|
| Outputs per Module | 6 (Sink) |
| Operating Voltage Range | 5-27 VDC |
| Output Voltage Range | 4-30 VDC |
| Maximum Output Current | 0.1 A/point; C3: 0.4 A/common, C4: 0.2 A/common |
| Minimum Output Current | 0.2 mA |
| Maximum Leakage Current | 0.1 mA @ 30.0 VDC |
| On Voltage Drop | 0.5 VDC @ 0.1 A |
| Maximum Inrush Current | 150mA for 10ms |
| OFF to ON Response | Y1: typ 5µs; Max 20µs Y2-6: < 0.5 ms |
| ON to OFF Response | Y1: typ 5µs; Max 20µs Y2-6: < 0.5 ms |
| Status Indicators | Logic Side (6 points, red LED) |
| Commons | 2 (4 points/com & 2 points/com) |
| External DC Power Required | 20-28 VDC Maximum @ 60mA (All Points On) |

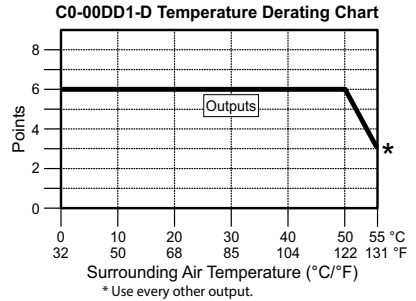

Equivalent Output Circuit

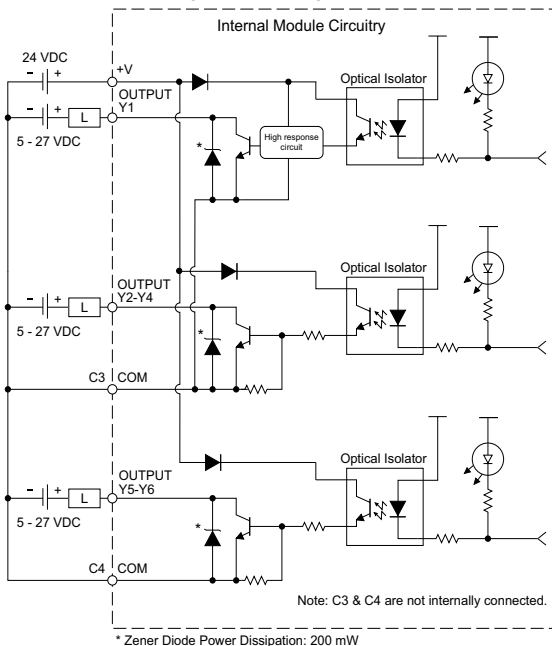

ZIPLink Pre-Wired PLC Connection Cables and Modules for CLICK PLC

- 20-pin connector cable
- ZL-C0-CBL20 (0.5 m length)
- ZL-C0-CBL20-1 (1.0 m length)
- ZL-C0-CBL20-2 (2.0 m length)



- ZL-RTB20
- 20-pin feed-through connector module



C0-00DD2-D – 8 DC Input/6 Sourcing DC Output Micro PLC

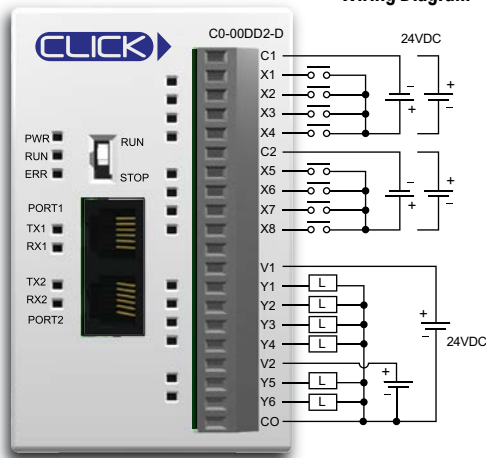

| Built-in I/O Specifications - Inputs | |
|--------------------------------------|--|
| Inputs per Module | 8 (Sink/Source) |
| Operating Voltage Range | 24VDC |
| Input Voltage Range | 21.6-26.4 VDC |
| Input Current | X1-2: Typ 5mA @ 24VDC X3-8: Typ 4mA @ 24VDC |
| Maximum Input Current | X1-2: 6.0 mA @ 26.4 VDC X3-8: 5.0 mA @ 26.4 VDC |
| Input Impedance | X1-2: 4.7 kΩ @ 24VDC X3-8: 6.8 kΩ @ 24VDC |
| ON Voltage Level | X1-2: > 19VDC X3-8: > 19VDC |
| OFF Voltage Level | X1-2: < 4VDC X3-8: < 7VDC |
| Minimum ON Current | X1-2: 4.5 mA X3-8: 3.5 mA |
| Maximum OFF Current | X1-2: 0.1 mA X3-8: 0.5 mA |
| OFF to ON Response | X1-2: Typ 5μs Max 20μs X3-8: Typ 2ms Max 10ms |
| ON to OFF Response | X1-2: Typ 5μs Max 20μs X3-8: Typ 3ms Max 10ms |
| Status Indicators | Logic Side (8 points, green LED) |
| Commons | 2 (4 points/common) Isolated |

| General Specifications | |
|-------------------------------------|---------------|
| Current Consumption at 24VDC | 120mA |
| Terminal Block Replacement Part No. | C0-16TB |
| Weight | 5.0 oz (140g) |

Equivalent Input Circuit

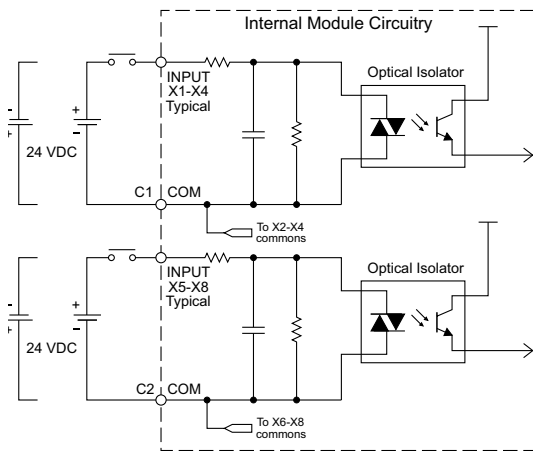

C0-00DD2-D Temperature Derating Chart

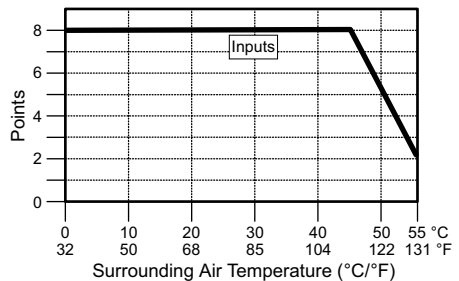

C0-00DD2-D – 8 DC Input/6 Sourcing DC Output Micro PLC (continued)

| Built-in I/O Specifications - Outputs | |
|---------------------------------------|---|
| Outputs per Module | 6 (Source) |
| Operating Voltage Range | 24VDC |
| Output Voltage Range | 19.2–30 VDC |
| Maximum Output Current | 0.1 A/point, 0.6 A/common |
| Minimum Output Current | 0.2 mA |
| Maximum Leakage Current | 0.1 mA @ 30VDC |
| On Voltage Drop | Y1: 1.0 VDC @ 0.1 A Y2-6: 0.5 VDC @ 0.1 A |
| Maximum Inrush Current | 150mA for 10ms |
| OFF to ON Response | Y1: typ 5 μ s; max 20 μ s Y2-6: < 0.5 ms |
| ON to OFF Response | Y1: typ 5 μ s; max 20 μ s Y2-6: < 0.5 ms |
| Status Indicators | Logic Side (6 points, red LED) |
| Commons | 1 (6 points/common) |

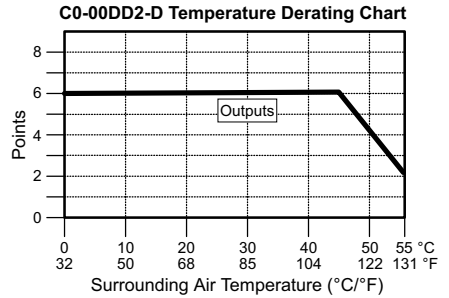

Equivalent Output Circuit

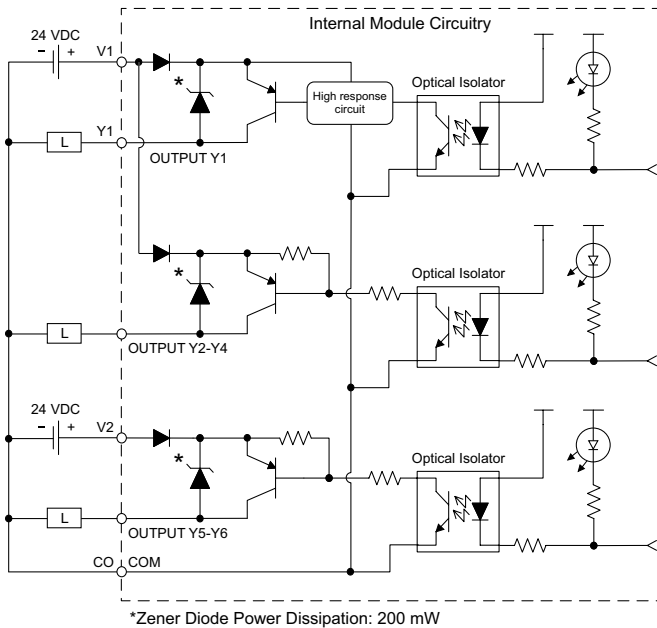

Z/PLink Pre-Wired PLC Connection Cables and Modules for CLICK PLC

- 20-pin connector cable
- ZL-C0-CBL20 (0.5 m length)
- ZL-C0-CBL20-1 (1.0 m length)
- ZL-C0-CBL20-2 (2.0 m length)



- ZL-RTB20
- 20-pin feed-through connector module



C0-00DR-D – 8 DC Input/6 Relay Output Micro PLC

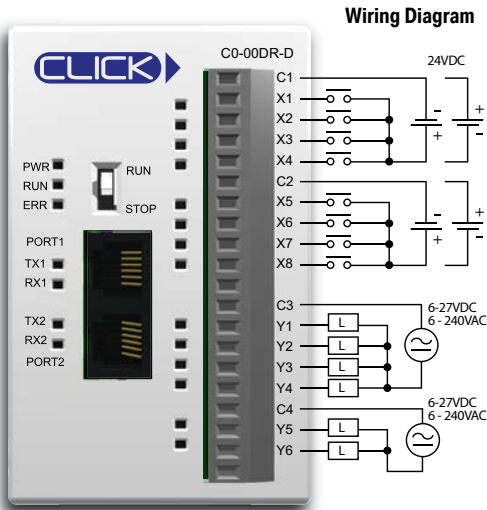

| Built-in I/O Specifications - Inputs | |
|--------------------------------------|--|
| Inputs per Module | 8 (Sink/Source) |
| Operating Voltage Range | 24VDC |
| Input Voltage Range | 21.6-26.4 VDC |
| Input Current | X1-2: Typ 5mA @ 24VDC X3-8: Typ 4mA @ 24VDC |
| Maximum Input Current | X1-2: 6.0 mA @ 26.4 VDC X3-8: 5.0 mA @ 26.4 VDC |
| Input Impedance | X1-2: 4.7 kΩ @ 24VDC X3-8: 6.8 kΩ @ 24VDC |
| ON Voltage Level | X1-2: > 19VDC X3-8: > 19VDC |
| OFF Voltage Level | X1-2: < 4VDC X3-8: < 7VDC |
| Minimum ON Current | X1-2: 4.5 mA X3-8: 3.5 mA |
| Maximum OFF Current | X1-2: 0.1 mA X3-8: 0.5 mA |
| OFF to ON Response | X1-2: Typ 5μs Max 20μs X3-8: Typ 2ms Max 10ms |
| ON to OFF Response | X1-2: Typ 5μs Max 20μs X3-8: Typ 3ms Max 10ms |
| Status Indicators | Logic Side (8 points, green LED) |
| Commons | 2 (4 points/common) Isolated |

| General Specifications | |
|-------------------------------------|---------------|
| Current Consumption at 24VDC | 120mA |
| Terminal Block Replacement Part No. | C0-16TB |
| Weight | 5.6 oz (160g) |

Equivalent Input Circuit

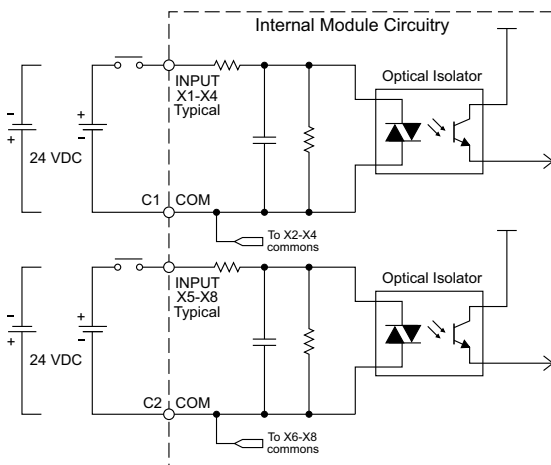

C0-00DR-D Temperature Derating Chart

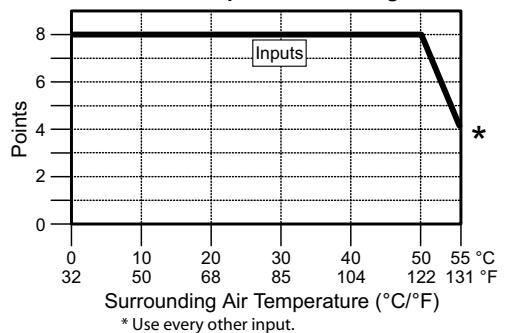

C0-00DR-D – 8 DC Input/6 Relay Output Micro PLC (continued)

| Built-in I/O Specifications - Outputs | |
|---------------------------------------|--|
| Outputs per Module | 6 |
| Operating Voltage Range | 6-240 VAC (47-63 Hz), 6-27 VDC |
| Output Voltage Range | 5-264 VAC (47-63 Hz), 5-30 VDC |
| Output Type | Relay, form A (SPST) |
| Maximum Current | 1 A/point; C3: 4A/common, C4: 2A/common |
| Minimum Load Current | 5mA @ 5VDC |
| Maximum Inrush Current | 3A for 10ms |
| OFF to ON Response | < 15ms |
| ON to OFF Response | < 15ms |
| Status Indicators | Logic Side (6 points, red LED) |
| Commons | 2 (4 points/com & 2 points/com) Isolated |

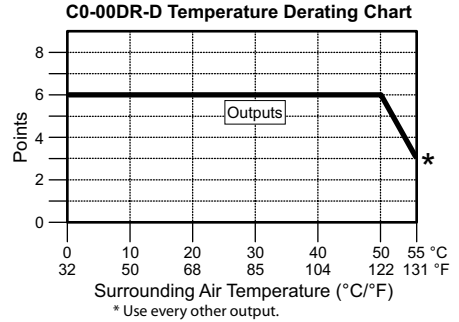

| Typical Relay Life (Operations) at Room Temperature | |
|---|----------------|
| Voltage & Load Type | Relay Life |
| 30VDC, 1A Resistive | 300,000 cycles |
| 30VDC, 1A Solenoid | 50,000 cycles |
| 250VAC, 1A Resistive | 500,000 cycles |
| 250VAC, 1A Solenoid | 200,000 cycles |
| ON to OFF = 1 cycle | |

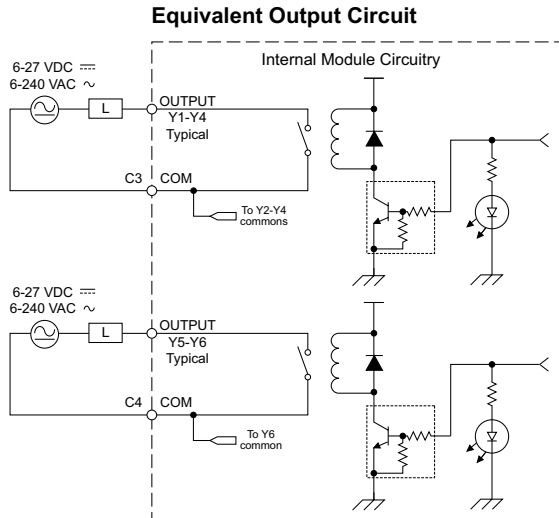

ZIPLink Pre-Wired PLC Connection Cables and Modules for CLICK PLC

- 20-pin connector cable
- ZL-C0-CBL20 (0.5 m length)
- ZL-C0-CBL20-1 (1.0 m length)
- ZL-C0-CBL20-2 (2.0 m length)



ZL-RTB20
20-pin feed-through connector module



NOTE: The C0-00DR-D is derated to 2A maximum per Common when used with the ZIPLink wiring system.

C0-00AR-D – 8 AC Input/6 Relay Output Micro PLC

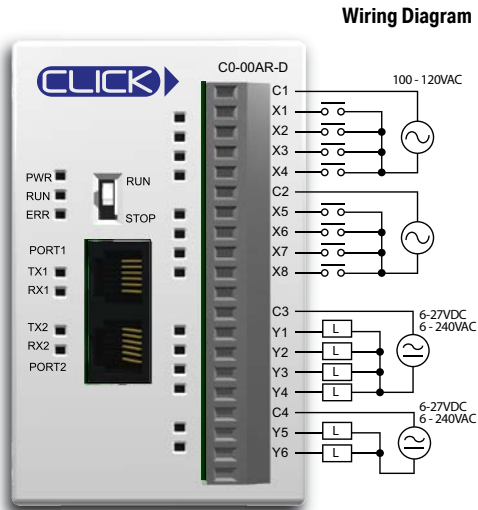

| Built-in I/O Specifications - Inputs | |
|--------------------------------------|--|
| Inputs per Module | 8 |
| Operating Voltage Range | 100-120 VAC |
| Input Voltage Range | 80-144 VAC |
| AC Frequency | 47-63 Hz |
| Input Current | 8.5 mA @ 100VAC at 50Hz 10mA @ 100VAC at 60Hz |
| Maximum Input Current | 16mA @ 144VAC at 55°C or 131°F |
| Input Impedance | 15kΩ @ 50Hz 12kΩ @ 60Hz |
| ON Voltage Level | > 60VAC |
| OFF Voltage Level | < 20VAC |
| Minimum ON Current | 5mA |
| Maximum OFF Current | 2mA |
| OFF to ON Response | Max 40ms |
| ON to OFF Response | Max 40ms |
| Status Indicators | Logic Side (8 points, green LED) |
| Commons | 2 (4 points/common) Isolated |

| General Specifications | |
|--|---------------|
| Current Consumption at 24VDC | 120mA |
| Terminal Block Replacement Part No. | C0-16TB |
| Weight | 5.6 oz (160g) |

Equivalent Input Circuit

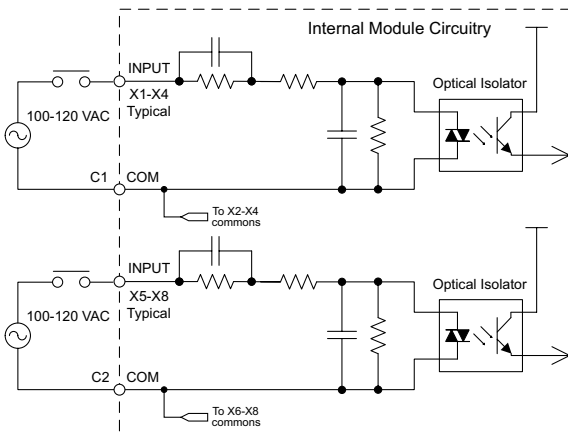

C0-00AR-D Temperature Derating Chart

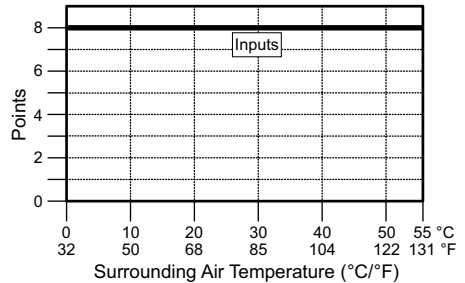

C0-00AR-D – 8 AC Input/6 Relay Output Micro PLC (continued)

| Built-in I/O Specifications - Outputs | |
|---------------------------------------|---|
| Outputs per Module | 6 |
| Operating Voltage Range | 6-240 VAC (47-63 Hz), 6-27 VDC |
| Output Voltage Range | 5-264 VAC (47-63 Hz), 5-30 VDC |
| Output Type | Relay, form A (SPST) |
| Maximum Current | 1A/point; C3: 4A/common, C4: 2A/common |
| Minimum Load Current | 5mA @ 5VDC |
| Maximum Inrush Current | 3A for 10ms |
| OFF to ON Response | < 15ms |
| ON to OFF Response | < 15ms |
| Status Indicators | Logic Side (6 points, red LED) |
| Commons | 2 (4 points/com & 2 points/com) Isolated |

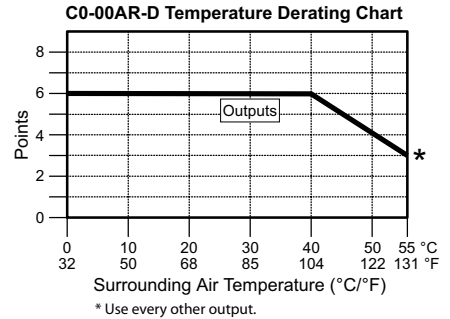

| Typical Relay Life (Operations) at Room Temperature | |
|---|----------------|
| Voltage & Load Type | Relay Life |
| 30VDC, 1A Resistive | 300,000 cycles |
| 30VDC, 1A Solenoid | 50,000 cycles |
| 250VAC, 1A Resistive | 500,000 cycles |
| 250VAC, 1A Solenoid | 200,000 cycles |
| ON to OFF = 1 cycle | |

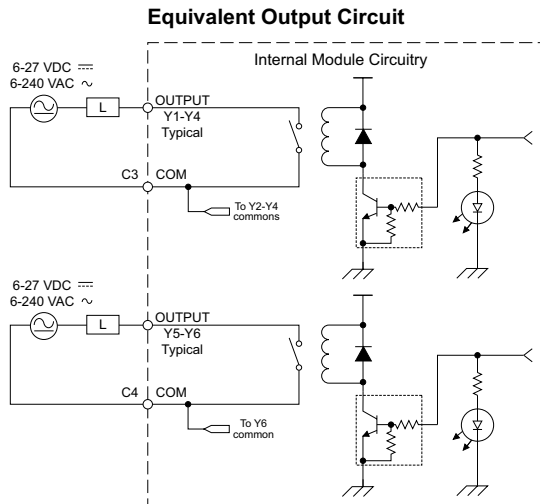

ZIPLink Pre-Wired PLC Connection Cables and Modules for CLICK PLC

- 20-pin connector cable
- ZL-C0-CBL20 (0.5 m length)
- ZL-C0-CBL20-1 (1.0 m length)
- ZL-C0-CBL20-2 (2.0 m length)



NOTE: The C0-00AR-D is derated to 2A maximum per Common when used with the ZIPLink wiring system.

ZL-RTB20
20-pin feed-through connector module



Standard PLC Unit Specifications

C0-01DD1-D – 8 DC Input/6 Sinking DC Output Micro PLC

Wiring Diagram

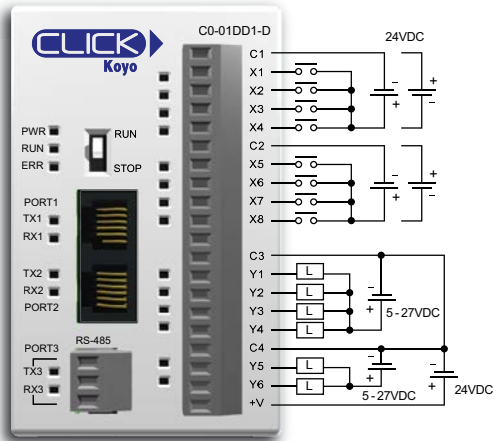

| Built-in I/O Specifications - Inputs | |
|--------------------------------------|--|
| Inputs per Module | 8 (Sink/Source) |
| Operating Voltage Range | 24VDC |
| Input Voltage Range | 21.6-26.4 VDC |
| Input Current | X1-2: Typ 5mA @ 24VDC X3-8: Typ 4mA @ 24VDC |
| Maximum Input Current | X1-2: 6.0 mA @ 26.4 VDC X3-8: 5.0 mA @ 26.4 VDC |
| Input Impedance | X1-2: 4.7 kΩ @ 24VDC X3-8: 6.8 kΩ @ 24VDC |
| ON Voltage Level | X1-2: > 19VDC X3-8: > 19VDC |
| OFF Voltage Level | X1-2: < 4VDC X3-8: < 7VDC |
| Minimum ON Current | X1-2: 4.5 mA X3-8: 3.5 mA |
| Maximum OFF Current | X1-2: 0.1 mA X3-8: 0.5 mA |
| OFF to ON Response | X1-2: Typ 5μs Max 20μs X3-8: Typ 2ms Max 10ms |
| ON to OFF Response | X1-2: Typ 5μs Max 20μs X3-8: Typ 3ms Max 10ms |
| Status Indicators | Logic Side (8 points, green LED) |
| Commons | 2 (4 points/common) Isolated |



NOTE: When using Standard PLCs, you must use CLICK programming software version V1.20 or later.

| General Specifications | |
|-------------------------------------|---------------|
| Current Consumption at 24VDC | 140mA |
| Terminal Block Replacement Part No. | C0-16TB |
| Weight | 5.0 oz (140g) |

Equivalent Input Circuit

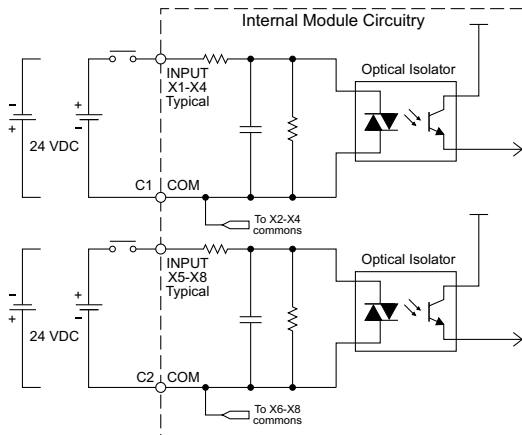

C0-01DD1-D Temperature Derating Chart

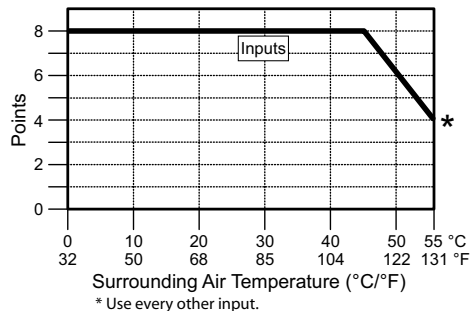

C0-01DD1-D – 8 DC Input/6 Sinking DC Output Micro PLC (continued)

| Built-in I/O Specifications - Outputs | |
|---------------------------------------|---|
| Outputs per Module | 6 (Sink) |
| Operating Voltage Range | 5-27 VDC |
| Output Voltage Range | 4-30 VDC |
| Maximum Output Current | 0.1 A/point; C3: 0.4 A/common, C4: 0.2 A/common |
| Minimum Output Current | 0.2 mA |
| Maximum Leakage Current | 0.1 mA @ 30.0 VDC |
| On Voltage Drop | 0.5 VDC @ 0.1 A |
| Maximum Inrush Current | 150mA for 10 ms |
| OFF to ON Response | Y1: typ 5 μ s; max 20 μ s Y2-6: < 0.5 ms |
| ON to OFF Response | Y1: Typ 5 μ s; max 20 μ s Y2-6: < 0.5 ms |
| Status Indicators | Logic Side (6 points, red LED) |
| Commons | 2 (4 points/com & 2 points/com) |
| External DC Power Required | 20-28 VDC Maximum @ 60mA (All Points On) |

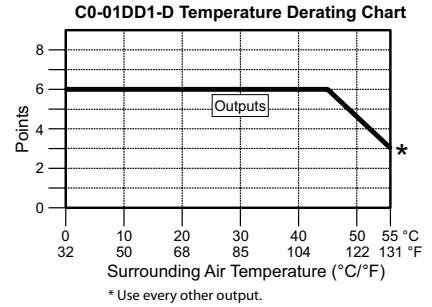

Equivalent Output Circuit

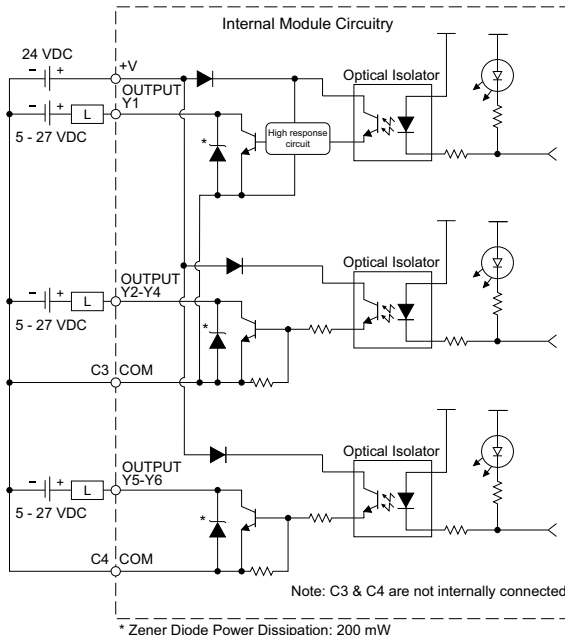

Z/PLink Pre-Wired PLC Connection Cables and Modules for CLICK PLC

- 20-pin connector cable
- ZL-C0-CBL20 (0.5 m length)
- ZL-C0-CBL20-1 (1.0 m length)
- ZL-C0-CBL20-2 (2.0 m length)



ZL-RTB20
20-pin feed-through connector module



C0-01DD2-D – 8 DC Input/6 Sourcing DC Output Micro PLC

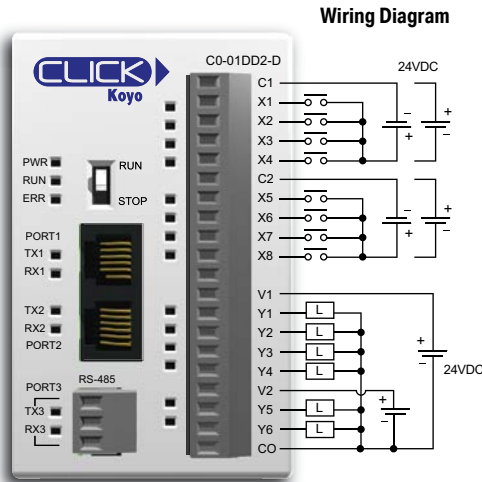

Wiring Diagram

| Built-in I/O Specifications - Inputs | |
|--------------------------------------|--|
| Inputs per Module | 8 (Sink/Source) |
| Operating Voltage Range | 24VDC |
| Input Voltage Range | 21.6–26.4 VDC |
| Input Current | X1-2: Typ 5mA @ 24VDC X3-8: Typ 4mA @ 24VDC |
| Maximum Input Current | X1-2: 6.0 mA @ 26.4 VDC X3-8: 5.0 mA @ 26.4 VDC |
| Input Impedance | X1-2: 4.7 kΩ @ 24VDC X3-8: 6.8 kΩ @ 24VDC |
| ON Voltage Level | X1-2: > 19VDC X3-8: > 19VDC |
| OFF Voltage Level | X1-2: < 4VDC X3-8: < 7VDC |
| Minimum ON Current | X1-2: 4.5 mA X3-8: 3.5 mA |
| Maximum OFF Current | X1-2: 0.1 mA X3-8: 0.5 mA |
| OFF to ON Response | X1-2: Typ 5μs Max 20μs X3-8: Typ 2ms Max 10ms |
| ON to OFF Response | X1-2: Typ 5μs Max 20μs X3-8: Typ 3ms Max 10ms |
| Status Indicators | Logic Side (8 points, green LED) |
| Commons | 2 (4 points/common) Isolated |



NOTE: When using Standard PLCs, you must use CLICK programming software version V1.20 or later.

| General Specifications | |
|-------------------------------------|---------------|
| Current Consumption at 24VDC | 140mA |
| Terminal Block Replacement Part No. | C0-16TB |
| Weight | 5.0 oz (140g) |

Equivalent Input Circuit

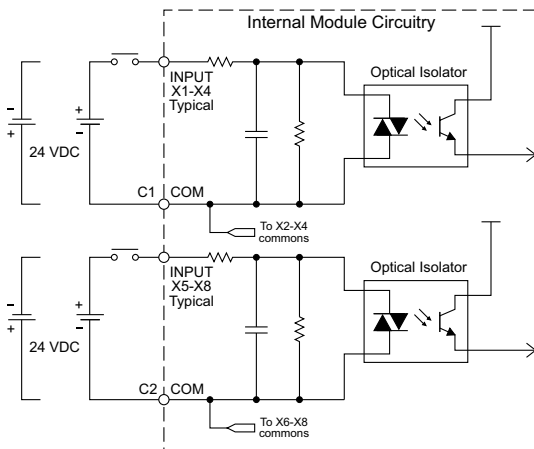

C0-01DD2-D Temperature Derating Chart

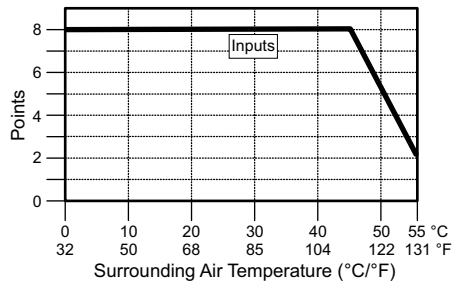

C0-01DD2-D – 8 DC Input/6 Sourcing DC Output Micro PLC (continued)

| Built-in I/O Specifications - Outputs | |
|---------------------------------------|---|
| Outputs per Module | 6 (Source) |
| Operating Voltage Range | 24VDC |
| Output Voltage Range | 19.2–30 VDC |
| Maximum Output Current | 0.1 A/point, 0.6 A/common |
| Minimum Output Current | 0.2 mA |
| Maximum Leakage Current | 0.1 mA @ 30VDC |
| On Voltage Drop | Y1: 1.0 VDC @ 0.1 A Y2-6: 0.5 VDC @ 0.1 A |
| Maximum Inrush Current | 150mA for 10ms |
| OFF to ON Response | Y1: Typ 5 μ s; Max 20 μ s Y2-6: < 0.5 ms |
| ON to OFF Response | Y1: Typ 5 μ s; Max 20 μ s Y2-6: < 0.5 ms |
| Status Indicators | Logic Side (6 points, red LED) |
| Commons | 1 (6 points/common) |

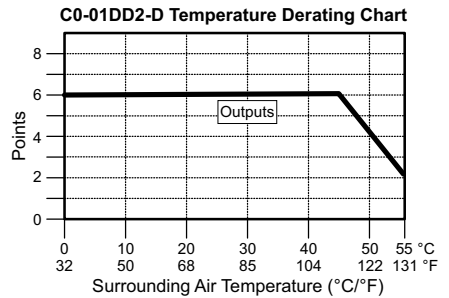

Equivalent Output Circuit

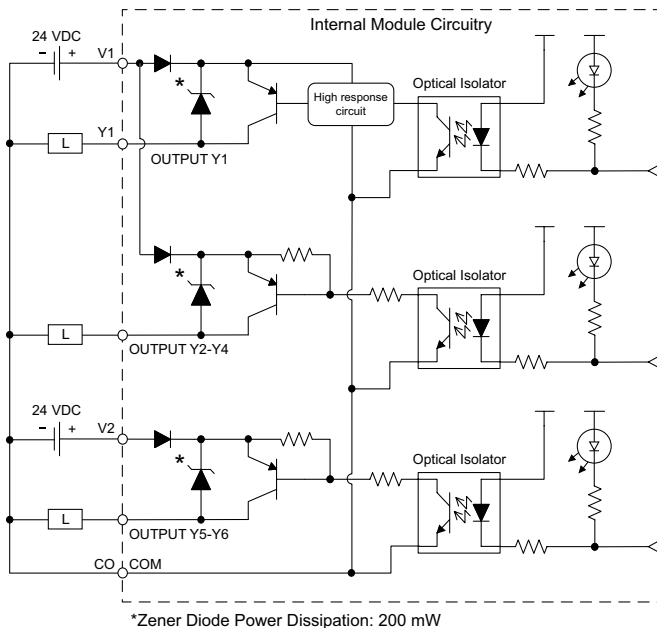

Z/PLink Pre-Wired PLC Connection Cables and Modules for CLICK PLC

- 20-pin connector cable
- ZL-C0-CBL20 (0.5 m length)
- ZL-C0-CBL20-1 (1.0 m length)
- ZL-C0-CBL20-2 (2.0 m length)



- ZL-RTB20
- 20-pin feed-through connector module



C0-01DR-D – 8 DC Input/6 Relay Output Micro PLC

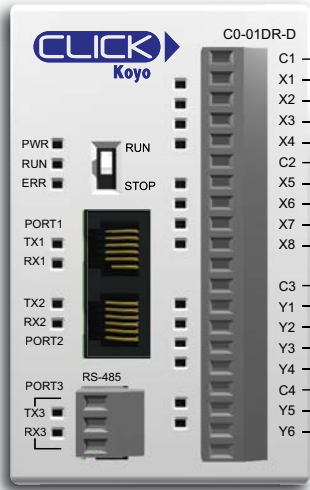

Wiring Diagram

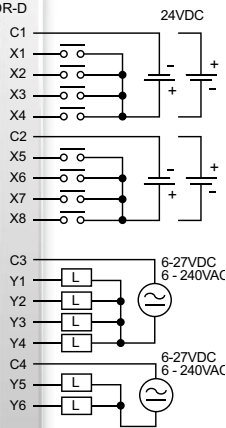

| Built-in I/O Specifications - Inputs | |
|--------------------------------------|--|
| Inputs per Module | 8 (Sink/Source) |
| Operating Voltage Range | 24VDC |
| Input Voltage Range | 21.6-26.4 VDC |
| Input Current | X1-2: Typ 5mA @ 24VDC X3-8: Typ 4mA @ 24VDC |
| Maximum Input Current | X1-2: 6.0 mA @ 26.4 VDC X3-8: 5.0 mA @ 26.4 VDC |
| Input Impedance | X1-2: 4.7 kΩ @ 24VDC X3-8: 6.8 kΩ @ 24VDC |
| ON Voltage Level | X1-2: > 19VDC X3-8: > 19VDC |
| OFF Voltage Level | X1-2: < 4VDC X3-8: < 7VDC |
| Minimum ON Current | X1-2: 4.5 mA X3-8: 3.5 mA |
| Maximum OFF Current | X1-2: 0.1 mA X3-8: 0.5 mA |
| OFF to ON Response | X1-2: Typ 5μs Max 20μs X3-8: Typ 2ms Max 10ms |
| ON to OFF Response | X1-2: Typ 5μs Max 20μs X3-8: Typ 3ms Max 10ms |
| Status Indicators | Logic Side (8 points, green LED) |
| Commons | 2 (4 points/common) Isolated |



NOTE: When using Standard PLCs, you must use CLICK programming software version V1.20 or later.

| General Specifications | |
|-------------------------------------|---------------|
| Current Consumption at 24VDC | 140mA |
| Terminal Block Replacement Part No. | C0-16TB |
| Weight | 5.6 oz (160g) |

Equivalent Input Circuit

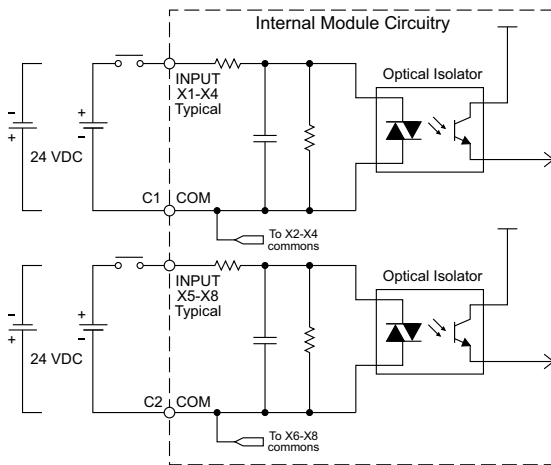

C0-01DR-D Temperature Derating Chart

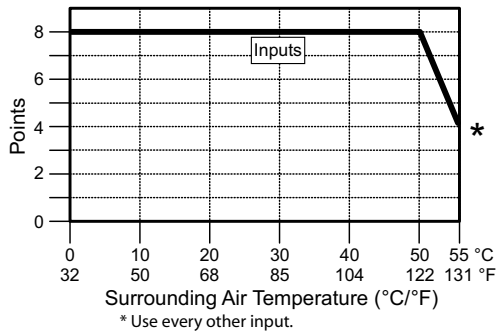

C0-01DR-D – 8 DC Input/6 Relay Output Micro PLC (continued)

| Built-in I/O Specifications - Outputs | |
|---------------------------------------|--|
| Outputs per Module | 6 |
| Operating Voltage Range | 6-240 VAC (47-63 Hz), 6-27 VDC |
| Output Voltage Range | 5-264 VAC (47-63 Hz), 5-30 VDC |
| Output Type | Relay, form A (SPST) |
| Maximum Current | 1A/point; C3: 4A/common, C4: 2A/common |
| Minimum Load Current | 5mA @ 5VDC |
| Maximum Inrush Current | 3A for 10ms |
| OFF to ON Response | < 15ms |
| ON to OFF Response | < 15ms |
| Status Indicators | Logic Side (6 points, red LED) |
| Commons | 2 (4 points/com & 2 points/com) Isolated |

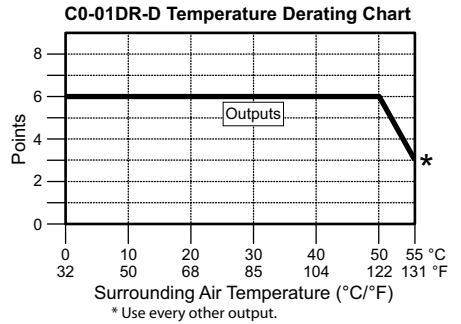

| Typical Relay Life (Operations) at Room Temperature | |
|---|----------------|
| Voltage & Load Type | Relay Life |
| 30VDC, 1A Resistive | 300,000 cycles |
| 30VDC, 1A Solenoid | 50,000 cycles |
| 250VAC, 1A Resistive | 500,000 cycles |
| 250VAC, 1A Solenoid | 200,000 cycles |
| ON to OFF = 1 cycle | |

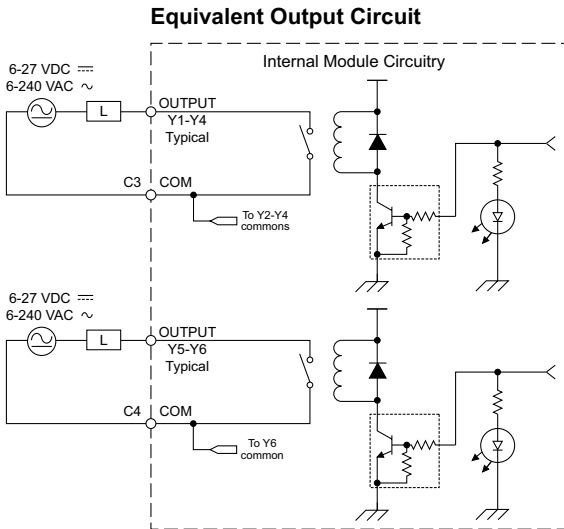

NOTE: The C0-01DR-D is derated to 2A maximum per Common when used with the ZIPLink wiring system.

ZIPLink Pre-Wired PLC Connection Cables and Modules for CLICK PLC

- 20-pin connector cable
- ZL-C0-CBL20 (0.5 m length)
- ZL-C0-CBL20-1 (1.0 m length)
- ZL-C0-CBL20-2 (2.0 m length)



- ZL-RTB20
- 20-pin feed-through connector module



C0-01AR-D – 8 AC Input/6 Relay Output Micro PLC

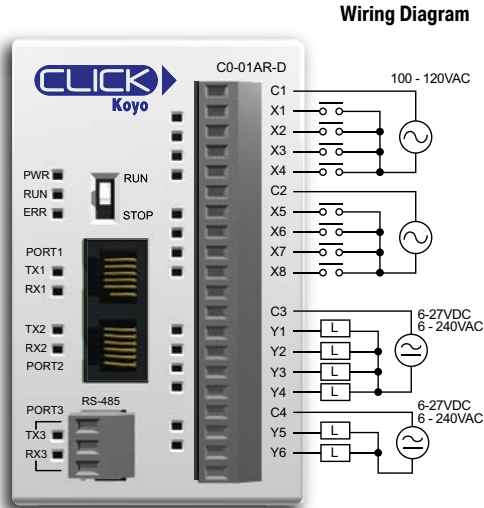

| Built-in I/O Specifications - Inputs | |
|--------------------------------------|---|
| Inputs per Module | 8 |
| Operating Voltage Range | 100–120 VAC |
| Input Voltage Range | 80–144 VAC |
| AC Frequency | 47–63 Hz |
| Input Current | 8.5 mA @ 100VAC at 50Hz 10 mA @ 100VAC at 60Hz |
| Maximum Input Current | 16 mA @ 144VAC |
| Input Impedance | 15kΩ @ 50Hz 12kΩ @ 60Hz |
| ON Voltage Level | > 60VAC |
| OFF Voltage Level | < 20VAC |
| Minimum ON Current | 5mA |
| Maximum OFF Current | 2mA |
| OFF to ON Response | Max 40ms |
| ON to OFF Response | Max 40ms |
| Status Indicators | Logic Side (8 points, green LED) |
| Commons | 2 (4 points/common) Isolated |

| General Specifications | |
|-------------------------------------|---------------|
| Current Consumption at 24VDC | 140mA |
| Terminal Block Replacement Part No. | C0-16TB |
| Weight | 5.6 oz (160g) |



NOTE: When using Standard PLCs, you must use **CLICK programming software version V1.20 or later.**

Equivalent Input Circuit

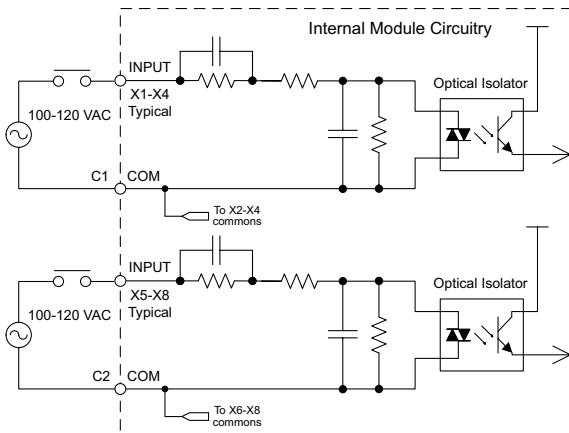

C0-01AR-D Temperature Derating Chart

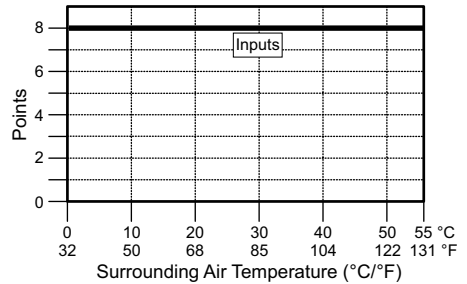

C0-01AR-D – 8 AC Input/6 Relay Output Micro PLC (continued)

| Built-in I/O Specifications - Outputs | |
|---------------------------------------|--|
| Outputs per Module | 6 |
| Operating Voltage Range | 6–240 VAC (47–63 Hz), 6–27 VDC |
| Output Voltage Range | 5–264 VAC (47–63 Hz), 5–30 VDC |
| Output Type | Relay, form A (SPST) |
| Maximum Current | 1 A/point; C3: 4A/common, C4: 2A/common |
| Minimum Load Current | 5mA @ 5VDC |
| Maximum Inrush Current | 3A for 10ms |
| OFF to ON Response | < 15ms |
| ON to OFF Response | < 15ms |
| Status Indicators | Logic Side (6 points, red LED) |
| Commons | 2 (4 points/com & 2 points/com) Isolated |

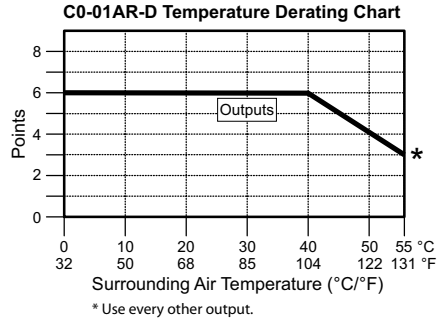

| Typical Relay Life (Operations) at Room Temperature | |
|---|----------------|
| Voltage & Load Type | Relay Life |
| 30VDC, 1A Resistive | 300,000 cycles |
| 30VDC, 1A Solenoid | 50,000 cycles |
| 250VAC, 1A Resistive | 500,000 cycles |
| 250VAC, 1A Solenoid | 200,000 cycles |
| ON to OFF = 1 cycle | |

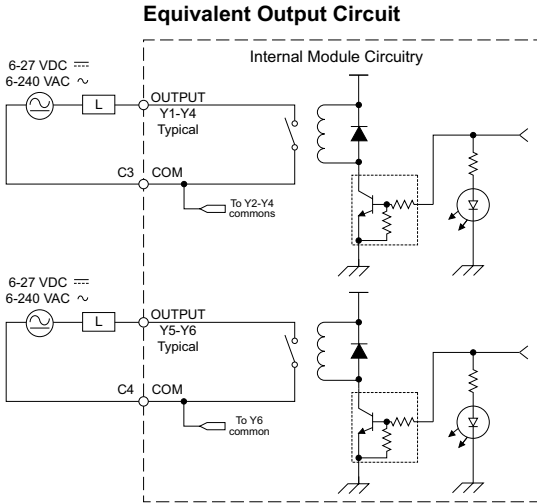

ZIPLink Pre-Wired PLC Connection Cables and Modules for CLICK PLC

- 20-pin connector cable
- ZL-C0-CBL20 (0.5 m length)
- ZL-C0-CBL20-1 (1.0 m length)
- ZL-C0-CBL20-2 (2.0 m length)



NOTE: The C0-01AR-D is derated to 2A maximum per Common when used with the ZIPLink wiring system.

ZL-RTB20
20-pin feed-through connector module



Analog PLC Unit Specifications

C0-02DD1-D – 4 DC Input/4 Sinking DC Output; 2 Analog In/2 Analog Out Micro PLC

Wiring Diagram

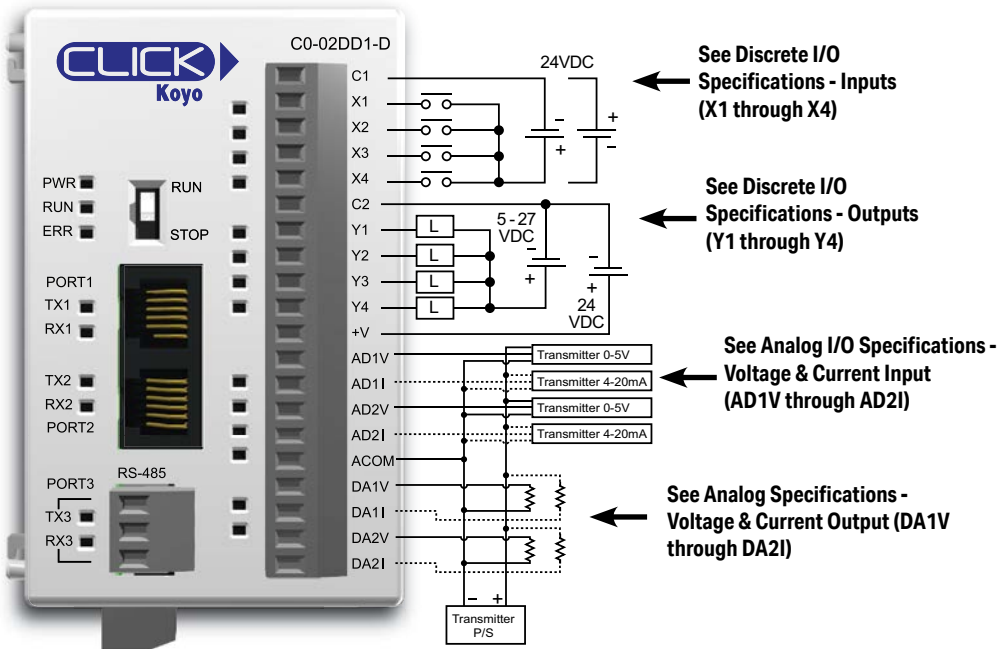

| General Specifications | |
|-------------------------------------|---------------|
| Current Consumption at 24VDC | 140mA |
| Terminal Block Replacement Part No. | C0-16TB |
| Weight | 5.3 oz (150g) |



WARNING: You must use proper software and firmware for this PLC unit.

| Serial Number | Software | Firmware |
|--------------------|----------------|----------------|
| Before 171208001 | V1.12 or later | V1.10 or later |
| 171208001 or later | V2.10 or later | V2.10 or later |

You can find the serial number on the bottom of the product label.

NOTE: Please refer to the Analog I/O Configuration section in Chapter 3 for information on using the analog I/O.



NOTE: There are no ZIPLink pre-wired PLC connection cables and modules for the Analog PLCs (cannot mix discrete I/O and analog I/O signals in a ZIPLink cable).

C0-02DD1-D (continued)

X1 - X4

| Discrete I/O Specifications - Inputs | |
|--------------------------------------|--|
| Inputs per Module | 4 (Sink/Source) |
| Operating Voltage Range | 24VDC |
| Input Voltage Range | 21.6–26.4 VDC |
| Input Current | X1-2: Typ 5mA @ 24VDC X3-4: Typ 4mA @ 24VDC |
| Maximum Input Current | X1-2: 6.0 mA @ 26.4 VDC X3-4: 5.0 mA @ 26.4 VDC |
| Input Impedance | X1-2: 4.7 kΩ @ 24VDC X3-4: 6.8 kΩ @ 24VDC |
| ON Voltage Level | X1-2: > 19VDC X3-4: > 7VDC |
| OFF Voltage Level | X1-2: < 4VDC X3-4: < 7VDC |
| Minimum ON Current | X1-2: 4.5 mA X3-4: 3.5 mA |
| Maximum OFF Current | X1-2: 0.1 mA X3-4: 0.5 mA |
| OFF to ON Response | X1-2: Typ 5μs Max 20μs* X3-4: Typ 2ms Max 10ms |
| ON to OFF Response | X1-2: Typ 5μs Max 20μs* X3-4: Typ 3ms Max 10ms |
| Status Indicators | Logic Side (4 points, green LED) |
| Commons | 1 (4 points/common) |

* Threshold level is 70% amplitude.

Equivalent Discrete Input Circuit

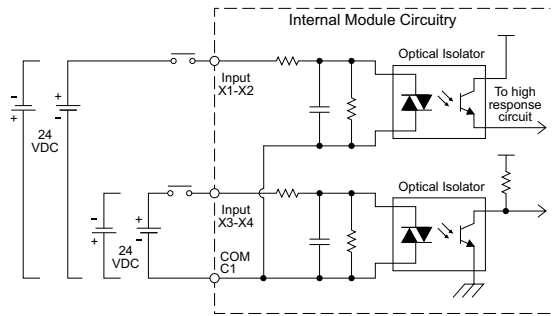

C0-02DD1-D Temperature Derating Chart

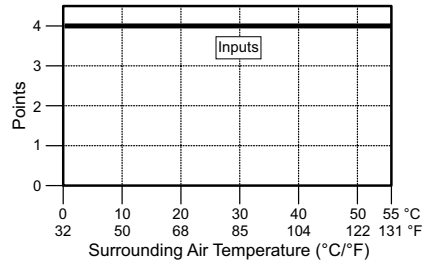

Y1 - Y4

| Discrete I/O Specifications - Outputs | |
|---------------------------------------|--|
| Outputs per Module | 4 (Sink) |
| Operating Voltage Range | 5–27 VDC |
| Output Voltage Range | 4–30 VDC |
| Maximum Output Current | 0.1 A/point; 0.4 A/common |
| Minimum Output Current | 0.2 mA |
| Maximum Leakage Current | 0.1 mA @ 30.0 VDC |
| On Voltage Drop | 0.5 VDC @ 0.1 A |
| Maximum Inrush Current | 150 mA for 10ms |
| OFF to ON Response | Y1: Typ 5μs; Max 20μs Y2-4: < 0.5 ms |
| ON to OFF Response | Y1: Typ 5μs; Max 20μs Y2-4: < 0.5 ms |
| Status Indicators | Logic Side (4 points, red LED) |
| Commons | 1 (4 points/common) |
| External DC Power Required | 20–28 VDC Maximum @ 60mA (all points on) |

Equivalent Discrete Output Circuit

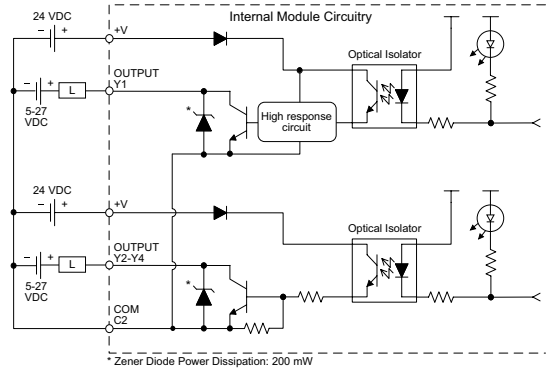

C0-02DD1-D Temperature Derating Chart

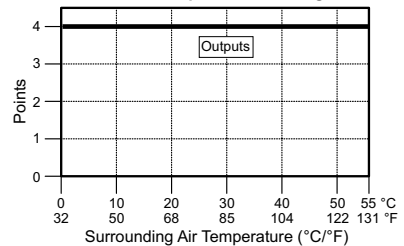

C0-02DD1-D (continued)

AD1V - AD2I

| Analog Specifications - Voltage Input | |
|---------------------------------------|---|
| Number of Channels | 2 (voltage/current selectable) |
| Input Range | 0-5 VDC (6VDC Max.) |
| Resolution | 12-bit |
| Conversion Time | 50ms |
| Input Impedance | 25kΩ 150kΩ (Serial numbers prior to 171208001) |
| Input Stability | ±2 LSB maximum |
| Full-Scale Calibration Error | ±1.2% maximum |
| Offset Calibration Error | ±5mV maximum |
| Accuracy vs. Temperature Error | ±100ppm / °C maximum |

Analog Voltage Input Circuit

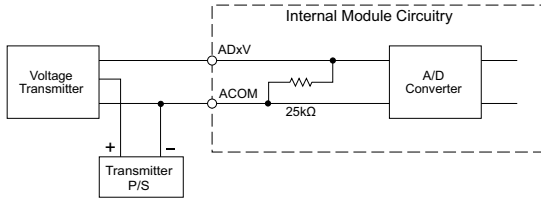

| Analog Specifications - Current Input | |
|---------------------------------------|--|
| Inputs per Module | 2 (voltage/current selectable) |
| Input Range | 4-20 mA (sink) |
| Resolution | 12-bit |
| Conversion Time | 50ms |
| Input Impedance | 100Ω 200Ω (Serial numbers prior to 171208001) |
| Input Stability | ±2 LSB |
| Full-Scale Calibration Error | ±1% maximum |
| Offset Calibration Error | ±0.1 mA maximum |
| Accuracy vs. Temperature Error | ±100ppm / °C maximum |

Analog Current Input Circuit

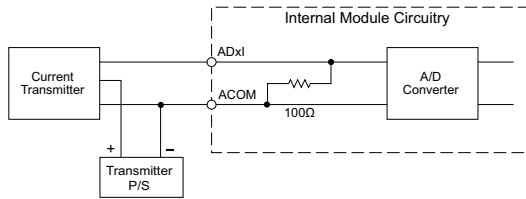

DA1V - DA2I

| Analog Specifications - Voltage Output | |
|--|--|
| Outputs per Module | 2 (voltage/current selectable) |
| Output Range | 0-5 VDC |
| Resolution | 12-bit |
| Conversion Time | 1ms |
| Load Impedance | 2kΩ minimum (output current 2.5 mA maximum) |
| Full-Scale Calibration Error | ±0.8% maximum |
| Offset Calibration Error | ±5mV maximum |
| Accuracy vs. Temperature Error | ±100ppm / °C maximum |

Analog Voltage Output Circuit

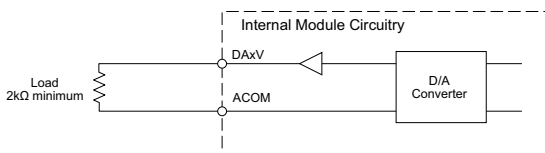

| Analog Specifications - Current Output | |
|--|---|
| Outputs per Module | 2 (voltage/current selectable) |
| Output Range | 4-20 mA (sink) |
| Resolution | 12-bit |
| Conversion Time | 1ms |
| Loop Supply Voltage | DC 18-30 V |
| Load Impedance | 250Ω Load Power Supply: DC 18V: 600Ω maximum DC 24V: 900Ω maximum DC 30V: 1200Ω maximum |
| Full-Scale Calibration Error | ±1% maximum |
| Offset Calibration Error | ±0.1 mA maximum |
| Accuracy vs. Temperature Error | ±100ppm / °C maximum |

Analog Current Output Circuit

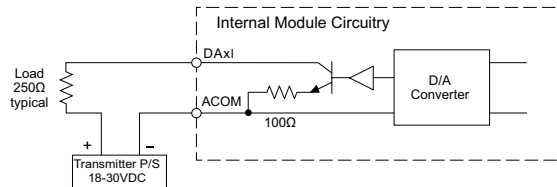

**C0-02DD2-D – 4 DC Input/4 Sourcing DC Output;
2 Analog In/2 Analog Out Micro PLC**

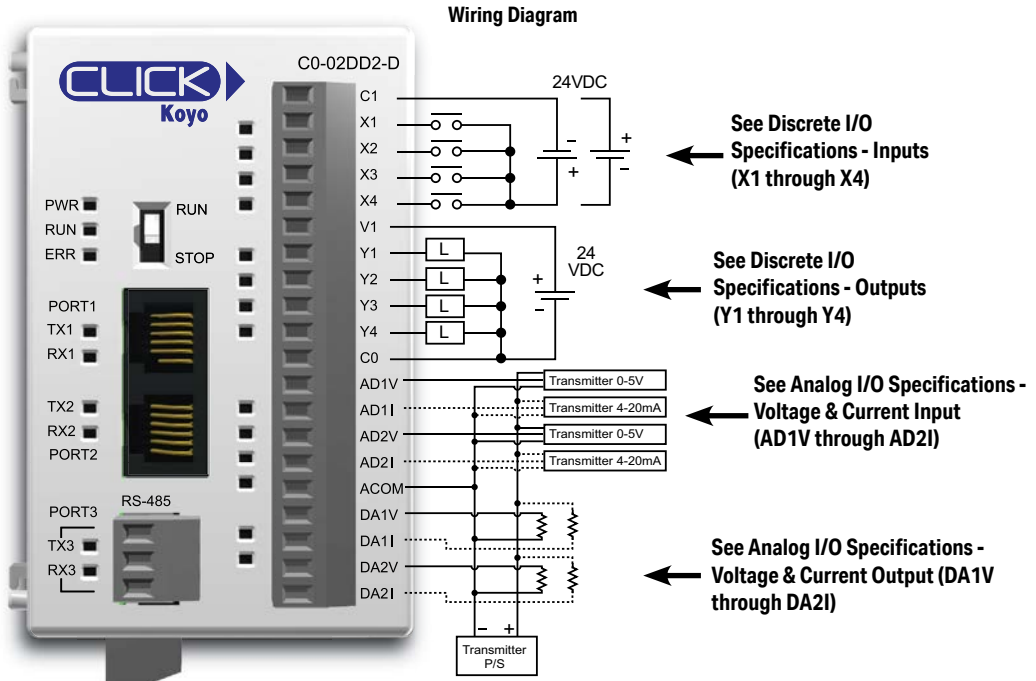

WARNING: You must use proper software and firmware for this PLC unit.

| Serial Number | Software | Firmware |
|--------------------|----------------|----------------|
| Before 174018001 | V1.12 or later | V1.10 or later |
| 174018001 or later | V2.10 or later | V2.10 or later |

You can find the serial number on the bottom of the product label.



NOTE: Please refer to the Analog I/O Configuration section in Chapter 3 for information on using the analog I/O.

NOTE: There are no ZIPLink pre-wired PLC connection cables and modules for the Analog PLCs (cannot mix discrete I/O and analog I/O signals in a ZIPLink cable).

C0-02DD2-D (continued)

X1 - X4

| Discrete I/O Specifications - Inputs | |
|--------------------------------------|--|
| Inputs per Module | 4 (Sink/Source) |
| Operating Voltage Range | 24VDC |
| Input Voltage Range | 21.6–26.4 VDC |
| Input Current | X1-2: Typ 5mA @ 24VDC X3-4: Typ 4mA @ 24VDC |
| Maximum Input Current | X1-2: 6.0 mA @ 26.4 VDC X3-4: 5.0 mA @ 26.4 VDC |
| Input Impedance | X1-2: 4.7 kΩ @ 24VDC X3-4: 6.8 kΩ @ 24VDC |
| ON Voltage Level | X1-2: > 19VDC X3-4: > 19VDC |
| OFF Voltage Level | X1-2: < 4VDC X3-4: < 7VDC |
| Minimum ON Current | X1-2: 4.5 mA X3-4: 3.5 mA |
| Maximum OFF Current | X1-2: 0.1 mA X3-4: 0.5 mA |
| OFF to ON Response | X1-2: Typ 5μs Max 20μs* X3-4: Typ 2ms Max 10ms |
| ON to OFF Response | X1-2: Typ 5μs Max 20μs* X3-4: Typ 3ms Max 10ms |
| Status Indicators | Logic Side (4 points, green LED) |
| Commons | 1 (4 points/common) |

* Threshold level is 70% amplitude.

Y1 - Y4

| Discrete I/O Specifications - Outputs | |
|---------------------------------------|--|
| Outputs per Module | 4 (Source) |
| Operating Voltage Range | 24VDC |
| Output Voltage Range | 19.2–30 VDC |
| Maximum Output Current | 0.1 A/point, 0.4 A/common |
| Minimum Output Current | 0.2 mA |
| Maximum Leakage Current | 0.1mA @ 30VDC |
| On Voltage Drop | Y1: 1 VDC @ 0.1A Y2-4: 0.5VDC @ 0.1mA |
| Maximum Inrush Current | 150mA for 10ms |
| OFF to ON Response | Y1: Typ 5μs; Max 20μs Y2-4: < 0.5 ms |
| ON to OFF Response | Y1: Typ 5μs; Max 20μs Y2-4: < 0.5 ms |
| Status Indicators | Logic Side (4 points, red LED) |
| Commons | 1 (4 points/common) |

Equivalent Discrete Input Circuit

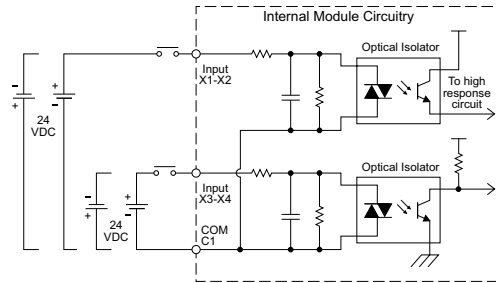

C0-02DD2-D Temperature Derating Chart

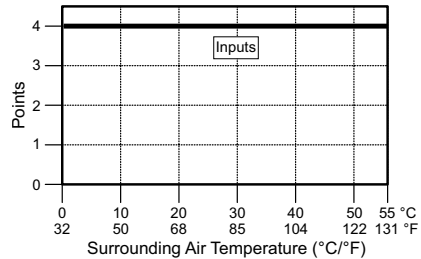

Equivalent Output Circuit

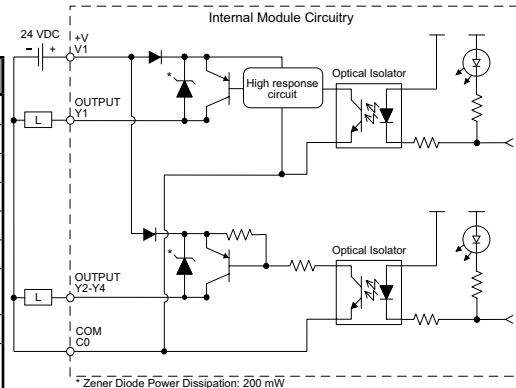

C0-02DD2-D Temperature Derating Chart

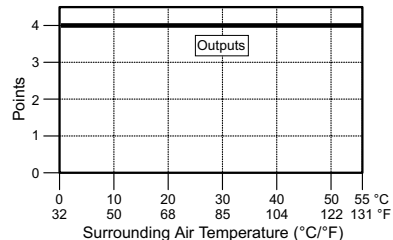

C0-02DD2-D (continued)

AD1V - AD2I

| Analog Specifications - Voltage Input | |
|---------------------------------------|---|
| Number of Channels | 2 (voltage/current selectable) |
| Input Range | 0-5 VDC (6 VDC Max.) |
| Resolution | 12-bit |
| Conversion Time | 50ms |
| Input Impedance | 25kΩ 150kΩ (Serial numbers prior to 174018001) |
| Input Stability | ±2 LSB maximum |
| Full-Scale Calibration Error | ±1.2% maximum |
| Offset Calibration Error | ±5mV maximum |
| Accuracy vs. Temperature Error | ±100ppm / °C maximum |

| Analog Specifications - Current Input | |
|---------------------------------------|--|
| Inputs per Module | 2 (voltage/current selectable) |
| Input Range | 4-20 mA (sink) |
| Resolution | 12-bit |
| Conversion Time | 50ms |
| Input Impedance | 100Ω 200Ω (Serial numbers prior to 174018001) |
| Input Stability | ±2 LSB |
| Full-Scale Calibration Error | ±1% maximum |
| Offset Calibration Error | ±0.1 mA maximum |
| Accuracy vs. Temperature Error | ±100ppm / °C maximum |

Analog Voltage Input Circuit

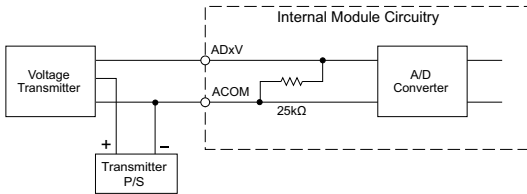

Analog Current Input Circuit

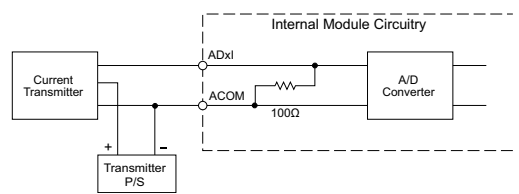

DA1V - DA2I

| Analog Specifications - Voltage Output | |
|--|--|
| Outputs per Module | 2 (voltage/current selectable) |
| Output Range | 0-5 VDC |
| Resolution | 12-bit |
| Conversion Time | 1ms |
| Load Impedance | 2kΩ minimum (output current 2.5 mA maximum) |
| Full-Scale Calibration Error | ±0.8% maximum |
| Offset Calibration Error | ±5mV maximum |
| Accuracy vs. Temperature Error | ±100ppm / °C maximum |

| Analog Specifications - Current Output | |
|--|---|
| Outputs per Module | 2 (voltage/current selectable) |
| Output Range | 4-20 mA (sink) |
| Resolution | 12-bit |
| Conversion Time | 1ms |
| Loop Supply Voltage | DC 18-30 V |
| Load Impedance | 250Ω Load Power Supply: DC 18V: 600Ω maximum DC 24V: 900Ω maximum DC 30V: 1200Ω maximum |
| Full-Scale Calibration Error | ±1% maximum |
| Offset Calibration Error | ±0.1 mA maximum |
| Accuracy vs. Temperature Error | ±100ppm / °C maximum |

Analog Voltage Output Circuit

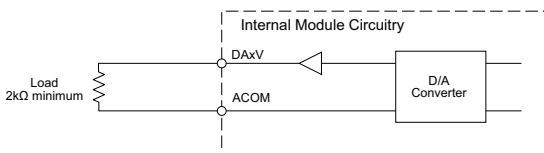

Analog Current Output Circuit

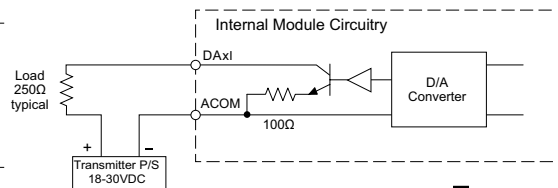

C0-02DR-D – 4 DC Input/4 Relay Output; 2 Analog In/2 Analog Out Micro PLC

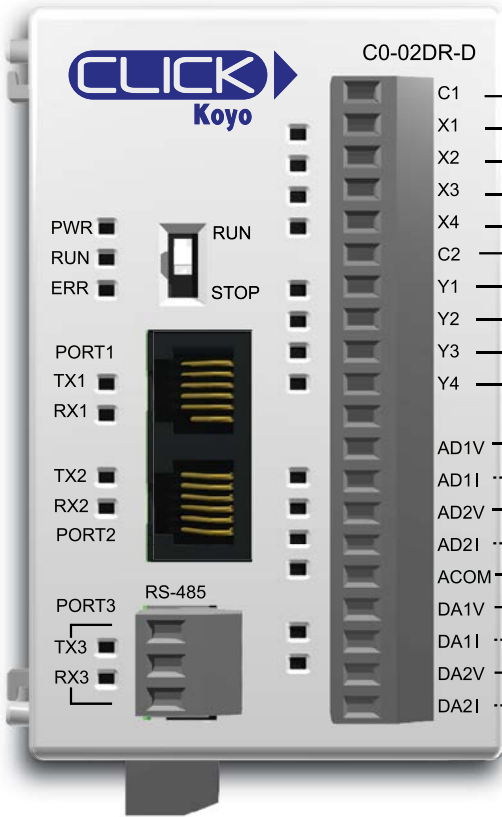

Wiring Diagram

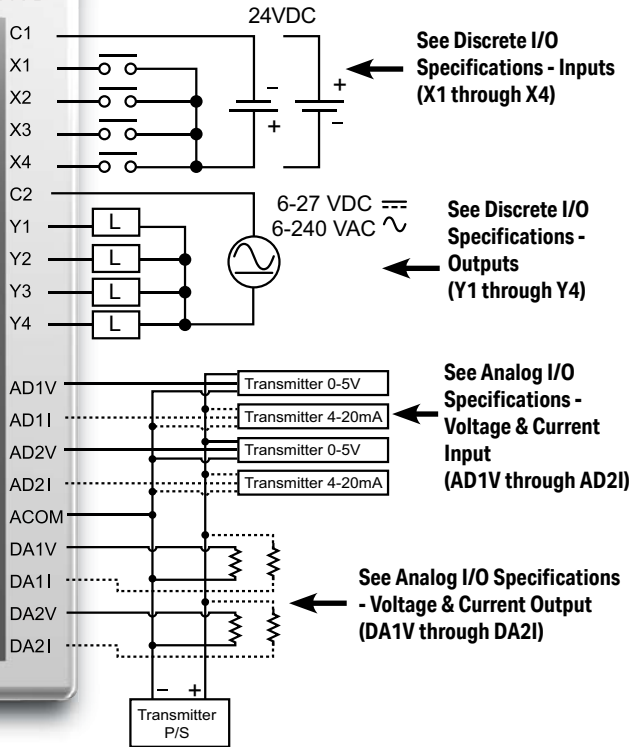

| General Specifications | |
|-------------------------------------|---------------|
| Current Consumption at 24VDC | 140mA |
| Terminal Block Replacement Part No. | C0-16TB |
| Weight | 5.6 oz (160g) |

| Typical Relay Life (Operations) at Room Temperature | |
|---|----------------|
| Voltage & Load Type | Relay Life |
| 30VDC, 1A Resistive | 300,000 cycles |
| 30VDC, 1A Solenoid | 50,000 cycles |
| 120VAC, 1A Resistive | 500,000 cycles |
| 120VAC, 1A Solenoid | 200,000 cycles |
| ON to OFF = 1 cycle | |



WARNING: You must use proper software and firmware for this PLC unit.

| Serial Number | Software | Firmware |
|--|----------------|----------------|
| Before 173158001 | V1.12 or later | V1.10 or later |
| 173158001 or later | V2.10 or later | V2.10 or later |
| You can find the serial number on the bottom of the product label. | | |

NOTE: Please refer to the Analog I/O Configuration section in Chapter 3 for information on using the analog I/O.



NOTE: There are no ZIPLink pre-wired PLC connection cables and modules for the Analog PLCs (cannot mix discrete I/O and analog I/O signals in a ZIPLink cable).

C0-02DR-D (continued)

X1 - X4

| Discrete I/O Specifications - Inputs | |
|--------------------------------------|---|
| Inputs per Module | 4 (Source/Sink) |
| Operating Voltage Range | 24VDC |
| Input Voltage Range | 21.6-26.4 VDC |
| Input Current | X1-2: Typ 5mA @ 24VDC X3-4: Typ 4mA @ 24VDC |
| Input Impedance | X1-2: 4.7 kΩ @ 24VDC X3-4: 6.8 kΩ @ 24VDC |
| ON Voltage Level | X1-2: > 19VDC X3-4: > 19VDC |
| OFF Voltage Level | X1-2: < 4VDC X3-4: < 7VDC |
| Minimum ON Current | X1-2: 4.5 mA X3-4: 3.5 mA |
| Maximum OFF Current | X1-2: 0.1 mA X3-4: 0.5 mA |
| OFF to ON Response | X1-2: Typ 5μs Max 20μs* X3-4: Typ 2ms Max 10ms |
| ON to OFF Response | X1-2: Typ 5μs Max 20μs* X3-4: Typ 3ms Max 10ms |
| Status Indicators | Logic Side (4 points, green LED) |
| Commons | 1 (4 points/common) |

* Threshold level is 70% amplitude.

Equivalent Discrete Input Circuit

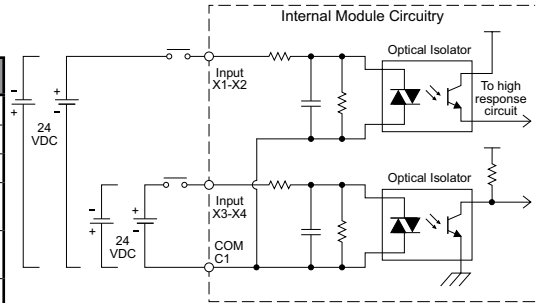

C0-02DR-D Temperature Derating Chart

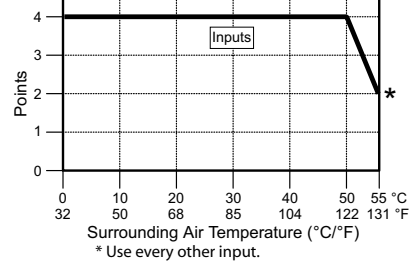

Y1 - Y4

| Discrete I/O Specifications - Outputs | |
|---------------------------------------|--|
| Outputs per Module | 4 |
| Operating Voltage Range | 6-27 VDC (-15%/+10%)/ 6-240 VAC (-10%/+10%) |
| Output Type | Relay, form A (SPST) |
| AC Frequency | 47-63 Hz |
| Maximum Current | 1A/point (resistive) |
| Minimum Load Current | 5mA @ 5VDC |
| Maximum Inrush Current | 3A for 10ms |
| OFF to ON Response | < 15ms |
| ON to OFF Response | < 15ms |
| Status Indicators | Logic Side (4 points, red LED) |
| Commons per Module | 1 (4 points/common) |
| Fuse | None |

Equivalent Output Circuit

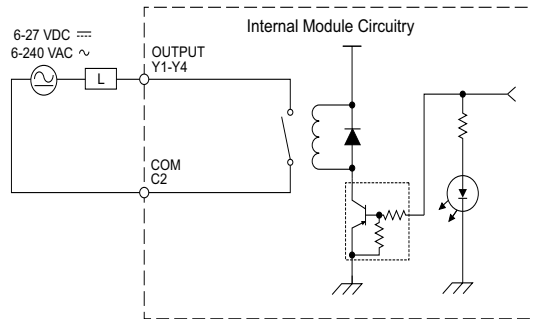

This circuit does not contain built-in protection. Install protection elements such as a fuse outside the module if necessary.

C0-02DR-D Temperature Derating Chart

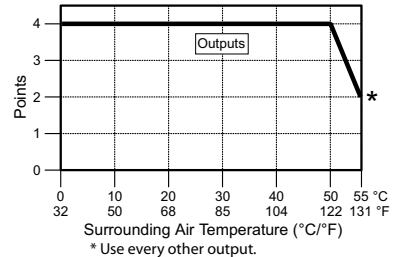

C0-02DR-D (continued)

AD1V – AD2I

| Analog Specifications - Voltage Input | |
|---------------------------------------|--|
| Number of Channels | 2 (voltage/current selectable) |
| Input Range | 0–5 VDC (6VDC Max.) |
| Resolution | 12-bit |
| Conversion Time | 50ms |
| Input Impedance | 25kΩ |
| Input Stability | 150Ω (Serial numbers prior to 173158001) |
| Full-Scale Calibration Error | ±2 LSB maximum |
| Offset Calibration Error | ±1.2% maximum |
| Accuracy vs. Temperature Error | ±5mV maximum |
| Accuracy vs. Temperature Error | ±100ppm / °C maximum |

| Analog Specifications - Current Input | |
|---------------------------------------|--|
| Inputs per Module | 2 (voltage/current selectable) |
| Input Range | 4–20 mA (sink) |
| Resolution | 12-bit |
| Conversion Time | 50ms |
| Input Impedance | 100Ω |
| Input Stability | 200Ω (Serial numbers prior to 173158001) |
| Full-Scale Calibration Error | ±2 LSB |
| Offset Calibration Error | ±1% maximum |
| Accuracy vs. Temperature Error | ±0.1 mA maximum |
| Accuracy vs. Temperature Error | ±100ppm / °C maximum |

Analog Voltage Input Circuit

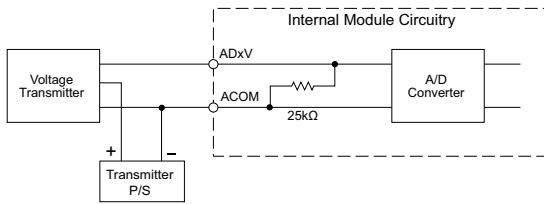

Analog Current Input Circuit

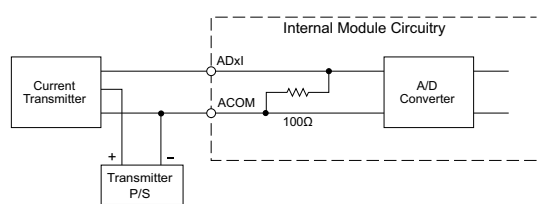

DA1V – DA2I

| Analog Specifications - Voltage Output | |
|--|---|
| Outputs per Module | 2 (voltage/current selectable) |
| Output Range | 0–5 VDC |
| Resolution | 12-bit |
| Conversion Time | 1ms |
| Load Impedance | 2kΩ minimum (output current 2.5 mA maximum) |
| Full-Scale Calibration Error | ±0.8% maximum |
| Offset Calibration Error | ±5mV maximum |
| Accuracy vs. Temperature Error | ±100ppm / °C maximum |

| Analog Specifications - Current Output | |
|--|---|
| Outputs per Module | 2 (voltage/current selectable) |
| Output Range | 4–20 mA (sink) |
| Resolution | 12-bit |
| Conversion Time | 1ms |
| Loop Supply Voltage | DC 18–30 V |
| Load Impedance | 250Ω Load Power Supply: DC 18V: 600Ω maximum DC 24V: 900Ω maximum DC 30V: 1200Ω maximum |
| Full-Scale Calibration Error | ±1% maximum |
| Offset Calibration Error | ±0.1 mA maximum |
| Accuracy vs. Temperature Error | ±100ppm / °C maximum |

Analog Voltage Output Circuit

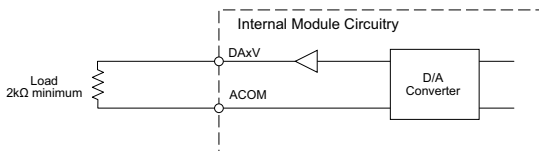

Analog Current Output Circuit

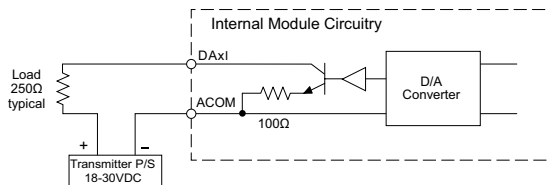

Ethernet Basic PLC Unit Specifications

C0-10DD1E-D – 8 DC Input/6 Sinking DC Output Micro PLC

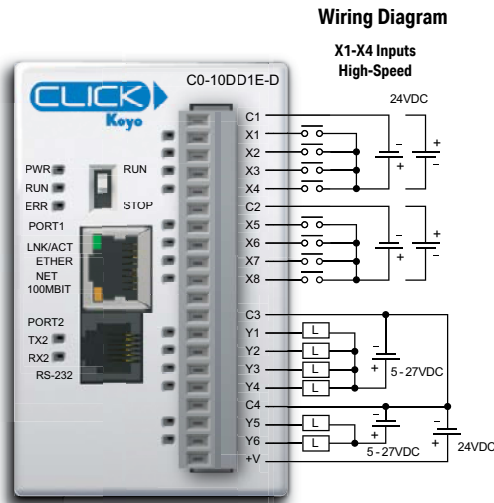

NOTE: When using Ethernet Basic PLCs, you must use CLICK programming software version V2.00 or later.

| Built-in I/O Specifications - Inputs | |
|--------------------------------------|--|
| Inputs per Module | 8 (Sink/Source) |
| Operating Voltage Range | 24VDC |
| Input Voltage Range | 21.6–26.4 VDC |
| Input Current | X1-4: Typ 6.5 mA @ 24VDC X5-8: Typ 4mA @ 24VDC |
| Maximum Input Current | X1-4: 7.0 mA @ 26.4 VDC X5-8: 5.0 mA @ 26.4 VDC |
| Input Impedance | X1-4: 3.9 kΩ @ 24VDC X5-8: 6.8 kΩ @ 24VDC |
| Input Frequency (Max) | X1-X4: 100kHz |
| ON Voltage Level | > 19VDC |
| OFF Voltage Level | X1-4: < 2VDC X5-8: < 7VDC |
| Minimum ON Current | X1-4: 4.5 mA X5-8: 3.5 mA |
| Maximum OFF Current | X1-4: 0.5 mA X5-8: 1.5 mA |
| OFF to ON Response | X1-4: Typ 3μs Max 5μs X5-8: Typ 2ms Max 10ms |
| ON to OFF Response | X1-4: Typ 1μs Max 20μs X5-8: Typ 3ms Max 10ms |
| Status Indicators | Logic Side (8 points, green LED) |
| Commons | 2 (4 points/common) Isolated |

| General Specifications | |
|-------------------------------------|---------------|
| Current Consumption at 24VDC | 120mA |
| Terminal Block Replacement Part No. | C0-16TB |
| Weight | 5.0 oz (140g) |

Equivalent Input Circuit

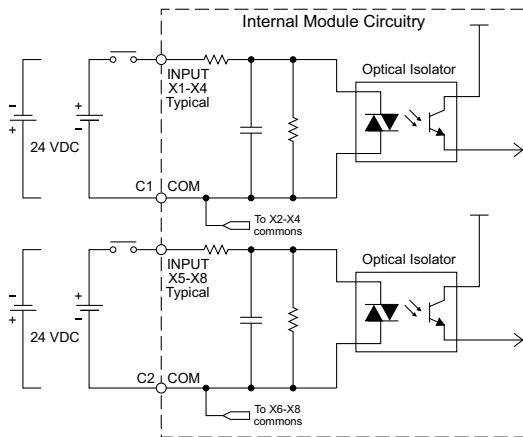

C0-10DD1E-D Temperature Derating Chart

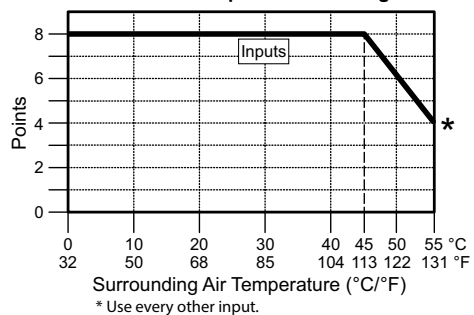

C0-10DD1E-D – 8 DC Input/6 Sinking DC Output Micro PLC (continued)

| Built-in I/O Specifications - Outputs | |
|---------------------------------------|---|
| Outputs per Module | 6 (Sink) |
| Operating Voltage Range | 5–27 VDC |
| Output Voltage Range | 4–30 VDC |
| Maximum Output Current | 0.1 A/point; C3: 0.4 A/common, C4: 0.2 A/common |
| Minimum Output Current | 0.2 mA |
| Maximum Leakage Current | 0.5 mA @ 30.0 VDC |
| On Voltage Drop | 0.5 VDC @ 0.1 A |
| Maximum Inrush Current | 150mA for 10ms |
| OFF to ON Response | Max. 0.5 ms |
| ON to OFF Response | Max. 0.5 ms |
| Status Indicators | Logic Side (6 points, red LED) |
| Commons | 2 (4 points/com & 2 points/com) |
| External DC Power Required | 20–28 VDC Maximum @ 60mA (All Points On) |

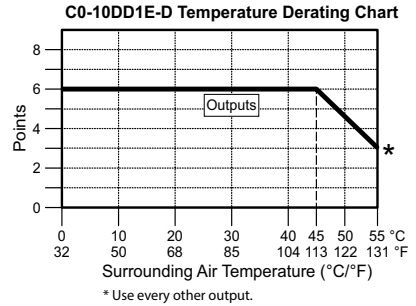

Equivalent Output Circuit

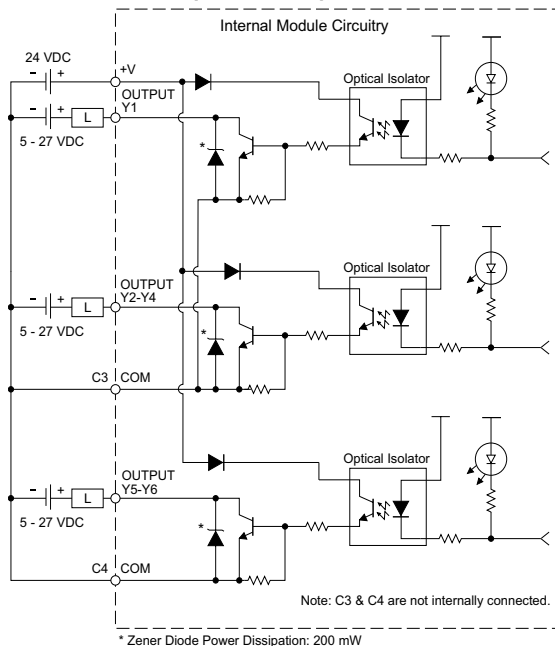

Z/PLink Pre-Wired PLC Connection Cables and Modules for CLICK PLC

- 20-pin connector cable
- ZL-C0-CBL20 (0.5 m length)
- ZL-C0-CBL20-1 (1.0 m length)
- ZL-C0-CBL20-2 (2.0 m length)



- ZL-RTB20
- 20-pin feed-through connector module



C0-10DD2E-D – 8 DC Input/6 Sourcing DC Output Micro PLC

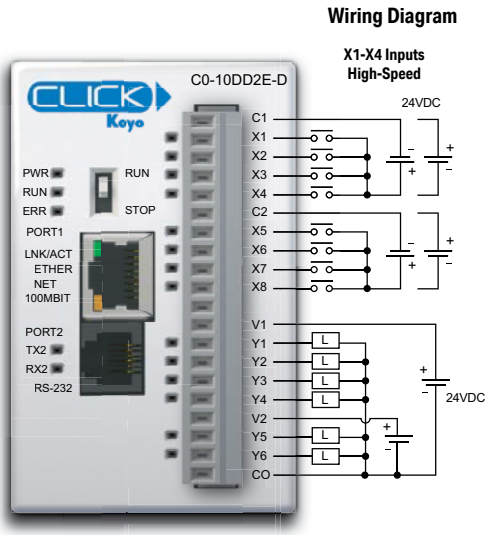

Wiring Diagram

| Built-in I/O Specifications - Inputs | |
|--------------------------------------|--|
| Inputs per Module | 8 (Sink/Source) |
| Operating Voltage Range | 24VDC |
| Input Voltage Range | 21.6–26.4 VDC |
| Input Current | X1-4: Typ 6.5 mA @ 24VDC X5-8: Typ 4mA @ 24VDC |
| Maximum Input Current | X1-4: 7.0 mA @ 26.4 VDC X5-8: 5.0 mA @ 26.4 VDC |
| Input Impedance | X1-4: 3.9 kΩ @ 24VDC X5-8: 6.8 kΩ @ 24VDC |
| Input Frequency (Max) | X1-X4: 100kHz |
| ON Voltage Level | > 19VDC |
| OFF Voltage Level | X1-4: < 2VDC X5-8: < 7VDC |
| Minimum ON Current | X1-4: 4.5 mA X5-8: 3.5 mA |
| Maximum OFF Current | X1-4: 0.5 mA X5-8: 1.5 mA |
| OFF to ON Response | X1-4: Typ 3μs Max 5μs X5-8: Typ 2ms Max 10ms |
| ON to OFF Response | X1-4: Typ 1μs Max 3μs X5-8: Typ 3ms Max 10ms |
| Status Indicators | Logic Side (8 points, green LED) |
| Commons | 2 (4 points/common) Isolated |



NOTE: When using Ethernet Basic PLCs, you must use CLICK programming software version V2.00 or later.

| General Specifications | |
|-------------------------------------|---------------|
| Current Consumption at 24VDC | 120mA |
| Terminal Block Replacement Part No. | C0-16TB |
| Weight | 5.0 oz (140g) |

Equivalent Input Circuit

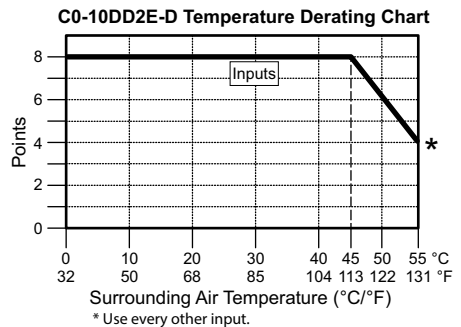
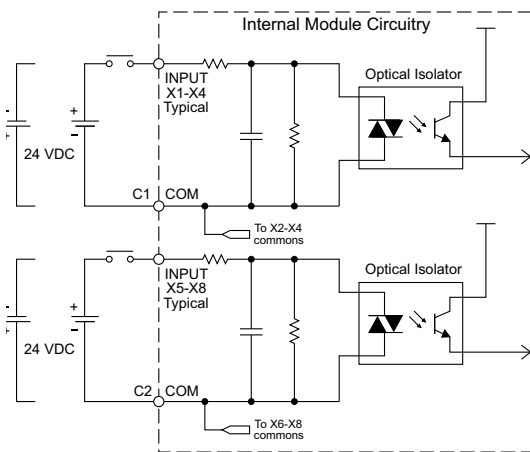

C0-10DD2E-D – 8 DC Input/6 Sourcing DC Output Micro PLC (continued)

| Built-in I/O Specifications - Outputs | |
|---------------------------------------|--------------------------------|
| Outputs per Module | 6 (Source) |
| Operating Voltage Range | 24VDC |
| Output Voltage Range | 19.2-30 VDC |
| Maximum Output Current | 0.1 A/point, 0.6 A/common |
| Minimum Output Current | 0.2 mA |
| Maximum Leakage Current | 0.1 mA @ 30VDC |
| On Voltage Drop | 0.5 VDC @ 0.1 A |
| Maximum Inrush Current | 150mA for 10ms |
| OFF to ON Response | Max. 0.5 ms |
| ON to OFF Response | Max 0.5 ms |
| Status Indicators | Logic Side (6 points, red LED) |
| Commons | 1 (6 points/common) |

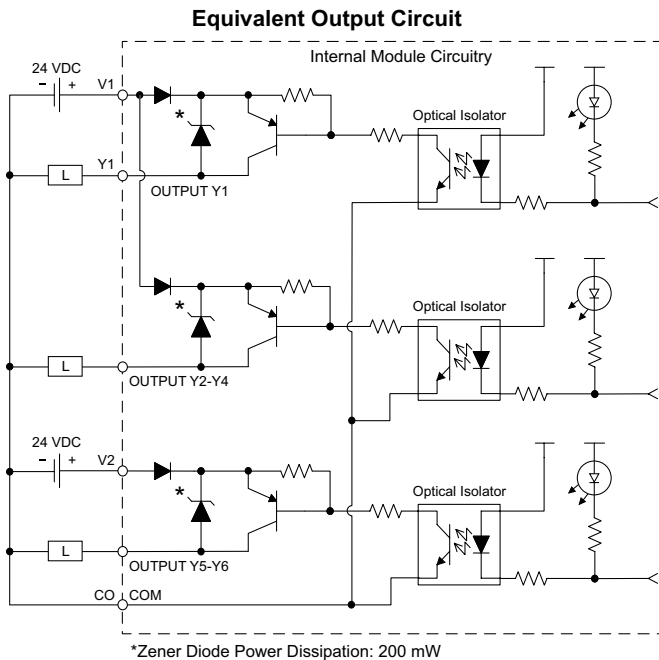
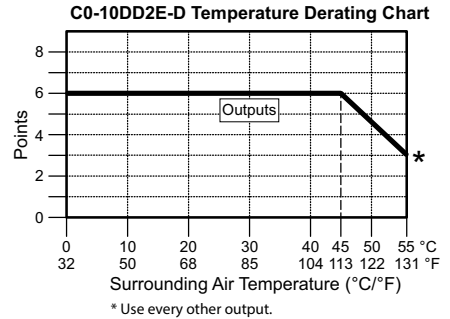

ZIPLink Pre-Wired PLC Connection Cables and Modules for CLICK PLC

- 20-pin connector cable
- ZL-C0-CBL20 (0.5 m length)
- ZL-C0-CBL20-1 (1.0 m length)
- ZL-C0-CBL20-2 (2.0 m length)



ZL-RTB20
20-pin feed-through connector module



C0-10DRE-D – 8 DC Input/6 Relay Output Micro PLC

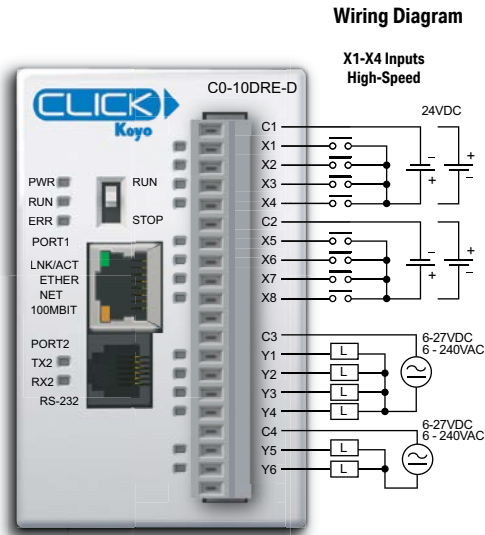

NOTE: When using Ethernet Basic PLCs, you must use CLICK programming software version V2.00 or later.

| Built-in I/O Specifications - Inputs | |
|--------------------------------------|--|
| Inputs per Module | 8 (Sink/Source) |
| Operating Voltage Range | 24VDC |
| Input Voltage Range | 21.6–26.4 VDC |
| Input Current | X1-4: Typ 6.5 mA @ 24VDC X5-8: Typ 4mA @ 24VDC |
| Maximum Input Current | X1-4: 7.0 mA @ 26.4 VDC X5-8: 5.0 mA @ 26.4 VDC |
| Input Impedance | X1-4: 3.9 kΩ @ 24VDC X5-8: 6.8 kΩ @ 24VDC |
| Input Frequency (Max) | X1-X4: 100kHz |
| ON Voltage Level | > 19VDC |
| OFF Voltage Level | X1-4: < 2VDC X5-8: < 7VDC |
| Minimum ON Current | X1-4: 4.5 mA X5-8: 3.5 mA |
| Maximum OFF Current | X1-4: 0.5 mA X5-8: 1.5 mA |
| OFF to ON Response | X1-4: Typ 3μs Max 5μs X5-8: Typ 2ms Max 10ms |
| ON to OFF Response | X1-4: Typ 1μs Max 3μs X5-8: Typ 3ms Max 10ms |
| Status Indicators | Logic Side (8 points, green LED) |
| Commons | 2 (4 points/common) Isolated |

| General Specifications | |
|-------------------------------------|---------------|
| Current Consumption at 24VDC | 120mA |
| Terminal Block Replacement Part No. | C0-16TB |
| Weight | 5.6 oz (160g) |

Equivalent Input Circuit

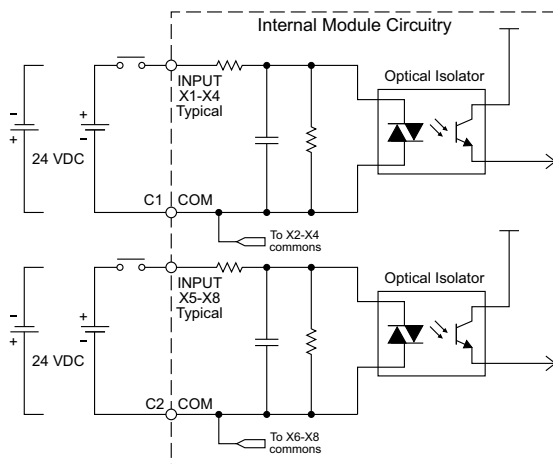

C0-10DRE-D Temperature Derating Chart

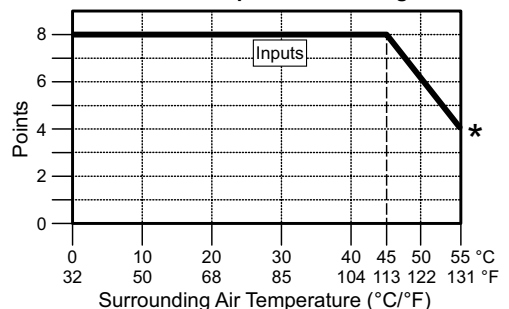

* Use every other input.

C0-10DRE-D – 8 DC Input/6 Relay Output Micro PLC (continued)

| Built-in I/O Specifications - Outputs | |
|---------------------------------------|--|
| Outputs per Module | 6 |
| Operating Voltage Range | 6-240 VAC (47-63 Hz), 6-27 VDC |
| Output Voltage Range | 5-264 VAC (47-63 Hz), 5-30 VDC |
| Output Type | Relay, form A (SPST) |
| Maximum Current | 1 A/point; C3: 4A/common, C4: 2A/common |
| Minimum Load Current | 5mA @ 5 VDC |
| Maximum Inrush Current | 3A for 10ms |
| OFF to ON Response | < 15ms |
| ON to OFF Response | < 15ms |
| Status Indicators | Logic Side (6 points, red LED) |
| Commons | 2 (4 points/com & 2 points/com) Isolated |

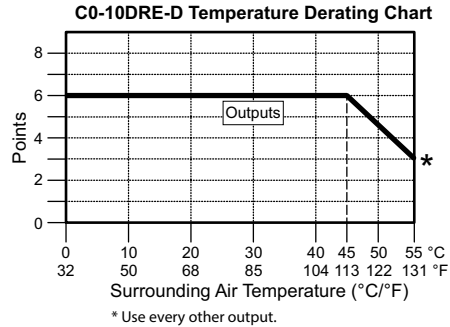

| Typical Relay Life (Operations) at Room Temperature | |
|---|----------------|
| Voltage & Load Type | Relay Life |
| 30VDC, 1A Resistive | 300,000 cycles |
| 30VDC, 1A Solenoid | 50,000 cycles |
| 250VAC, 1A Resistive | 500,000 cycles |
| 250VAC, 1A Solenoid | 200,000 cycles |
| ON to OFF = 1 cycle | |

ZIPLink Pre-Wired PLC Connection Cables and Modules for CLICK PLC

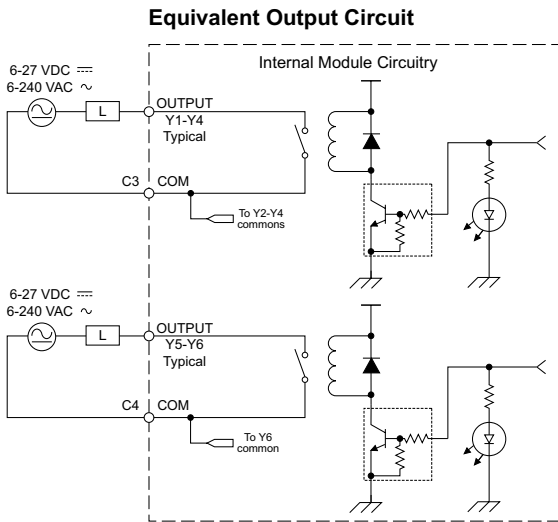

- 20-pin connector cable
- ZL-C0-CBL20 (0.5 m length)
- ZL-C0-CBL20-1 (1.0 m length)
- ZL-C0-CBL20-2 (2.0 m length)



- ZL-RTB20
- 20-pin feed-through connector module



NOTE: The C0-10DRE-D is derated to 2A maximum per Common when used with the ZIPLink wiring system.

C0-10ARE-D – 8 AC Input/6 Relay Output Micro PLC

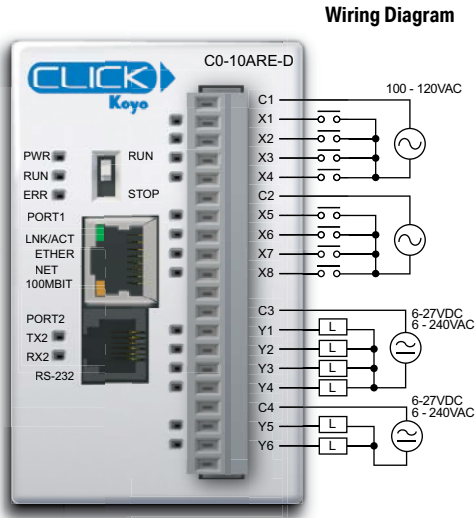

| Built-in I/O Specifications - Inputs | |
|--------------------------------------|--|
| Inputs per Module | 8 |
| Operating Voltage Range | 100-120 VAC |
| Input Voltage Range | 80-144 VAC |
| AC Frequency | 47-63 Hz |
| Input Current | 8.5 mA @ 100VAC at 50Hz 10mA @ 100VAC at 60Hz |
| Maximum Input Current | 16mA @ 144 VAC at 55°C or 131°F |
| Input Impedance | 15kΩ @ 50Hz 12kΩ @ 60Hz |
| ON Voltage Level | > 60 VAC |
| OFF Voltage Level | < 20 VAC |
| Minimum ON Current | 5mA |
| Maximum OFF Current | 2mA |
| OFF to ON Response | < 40ms |
| ON to OFF Response | < 40ms |
| Status Indicators | Logic Side (8 points, green LED) |
| Commons | 2 (4 points/common) Isolated |

| General Specifications | |
|-------------------------------------|---------------|
| Current Consumption at 24VDC | 120mA |
| Terminal Block Replacement Part No. | C0-16TB |
| Weight | 5.6 oz (160g) |



NOTE: When using Ethernet Basic PLCs, you must use CLICK programming software version V2.00 or later.

Equivalent Input Circuit

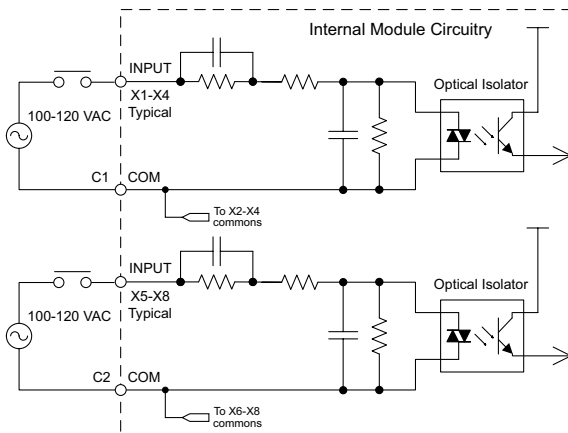

C0-10ARE-D Temperature Derating Chart

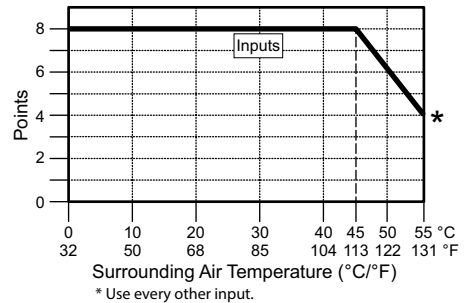

C0-10ARE-D – 8 AC Input/6 Relay Output Micro PLC (continued)

| Built-in I/O Specifications - Outputs | |
|---------------------------------------|---|
| Outputs per Module | 6 |
| Operating Voltage Range | 6–240 VAC (47–63 Hz), 6–27 VDC |
| Output Voltage Range | 5–264 VAC (47–63 Hz), 5–30 VDC |
| Output Type | Relay, form A (SPST) |
| Maximum Current | 1 A/point; C3: 4A/common, C4: 2A/common |
| Minimum Load Current | 5mA @ 5VDC |
| Maximum Inrush Current | 3A for 10ms |
| OFF to ON Response | < 15ms |
| ON to OFF Response | < 15ms |
| Status Indicators | Logic Side (6 points, red LED) |
| Commons | 2 (4 points/com & 2 points/com) Isolated |

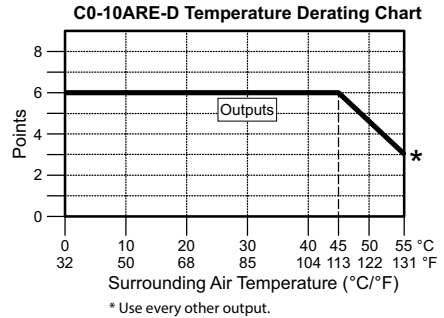

| Typical Relay Life (Operations) at Room Temperature | |
|---|----------------|
| Voltage & Load Type | Relay Life |
| 30VDC, 1A Resistive | 300,000 cycles |
| 30VDC, 1A Solenoid | 50,000 cycles |
| 250VAC, 1A Resistive | 500,000 cycles |
| 250VAC, 1A Solenoid | 200,000 cycles |
| ON to OFF = 1 cycle | |

Equivalent Output Circuit

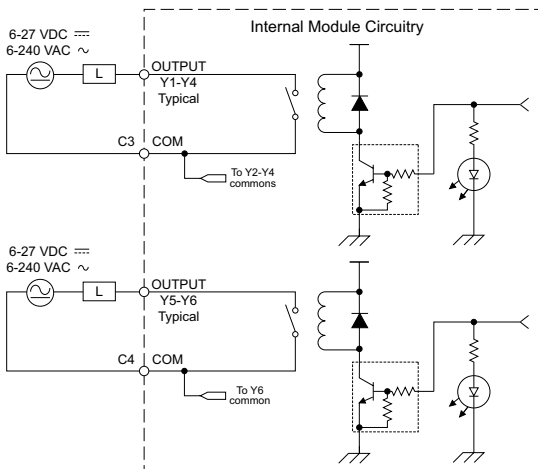

ZIPLink Pre-Wired PLC Connection Cables and Modules for CLICK PLC

- 20-pin connector cable
- ZL-C0-CBL20 (0.5 m length)
- ZL-C0-CBL20-1 (1.0 m length)
- ZL-C0-CBL20-2 (2.0 m length)



- ZL-RTB20
- 20-pin feed-through connector module



NOTE: The C0-10ARE-D is derated to 2A maximum per Common when used with the ZIPLink wiring system.

Ethernet Standard PLC Unit Specifications

C0-11DD1E-D – 8 DC Input/6 Sinking DC Output Micro PLC

Wiring Diagram

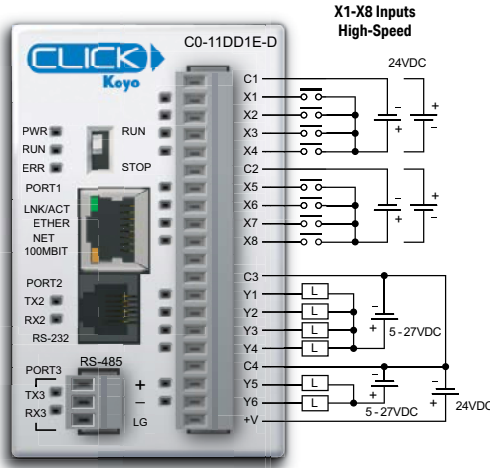

| Built-in I/O Specifications - Inputs | |
|--------------------------------------|----------------------------------|
| Inputs per Module | 8 (Sink/Source) |
| Operating Voltage Range | 24VDC |
| Input Voltage Range | 21.6-26.4 VDC |
| Input Current | Typ 6.5 mA @ 24VDC |
| Maximum Input Current | 7.0 mA @ 26.4 VDC |
| Input Impedance | 3.9 kΩ @ 24VDC |
| Input Frequency (Max) | X1-X8: 100kHz |
| ON Voltage Level | > 19VDC |
| OFF Voltage Level | < 2VDC |
| Minimum ON Current | 4.5 mA |
| Maximum OFF Current | 0.5 mA |
| OFF to ON Response | Typ 3μs Max 5μs |
| ON to OFF Response | Typ 1μs Max 3μs |
| Status Indicators | Logic Side (8 points, green LED) |
| Commons | 2 (4 points/common) Isolated |



NOTE: When using Ethernet Standard PLCs, you must use CLICK programming software version V2.00 or later.

| General Specifications | |
|-------------------------------------|---------------|
| Current Consumption at 24VDC | 140mA |
| Terminal Block Replacement Part No. | C0-16TB |
| Weight | 5.0 oz (140g) |

Equivalent Input Circuit

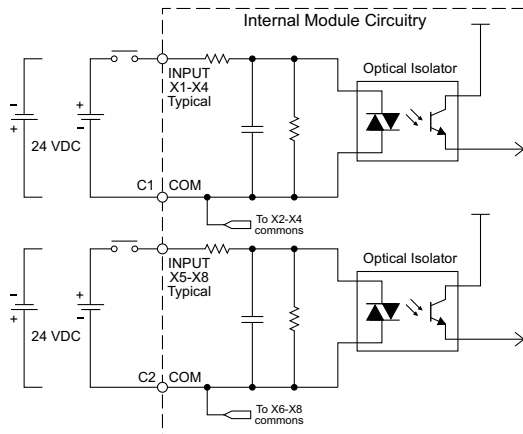

C0-11DD1E-D Temperature Derating Chart

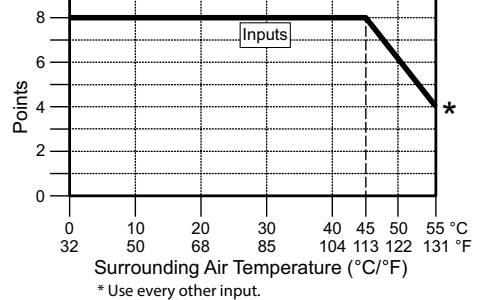

C0-11DDE1-D – 8 DC Input/6 Sinking DC Output Micro PLC (continued)

| Built-in I/O Specifications - Outputs | |
|---------------------------------------|---|
| Outputs per Module | 6 (Sink) |
| Operating Voltage Range | 5-27 VDC |
| Output Voltage Range | 4-30 VDC |
| Maximum Output Current | 0.1 A/point; C3: 0.4 A/common, C4: 0.2 A/common |
| Minimum Output Current | 0.2 mA |
| Maximum Leakage Current | 0.1 mA @ 30.0 VDC |
| On Voltage Drop | 0.5 VDC @ 0.1 A |
| Maximum Inrush Current | 150mA for 10ms |
| OFF to ON Response | Max. 0.5 ms |
| ON to OFF Response | Max. 0.5 ms |
| Status Indicators | Logic Side (6 points, red LED) |
| Commons | 2 (4 points/com & 2 points/com) |
| External DC Power Required | 20-28 VDC Maximum @ 60mA (All Points On) |

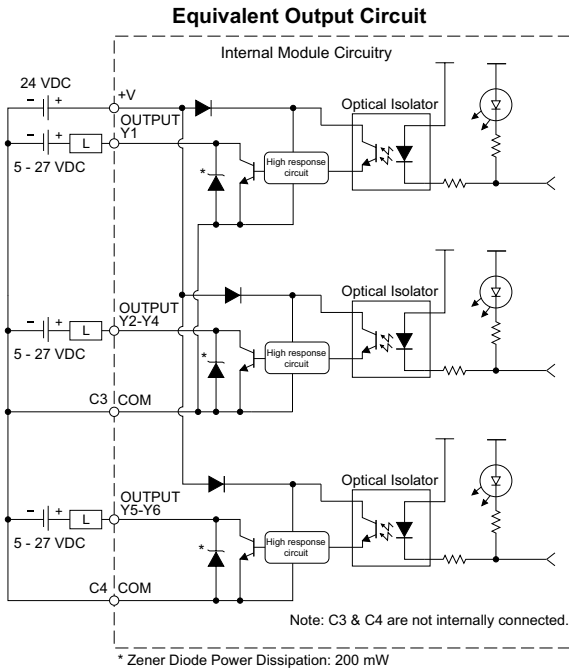
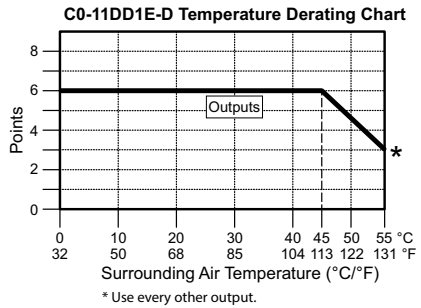

ZIPLink Pre-Wired PLC Connection Cables and Modules for CLICK PLC

- 20-pin connector cable
- ZL-C0-CBL20 (0.5 m length)
- ZL-C0-CBL20-1 (1.0 m length)
- ZL-C0-CBL20-2 (2.0 m length)



ZL-RTB20 20-pin feed-through connector module



C0-11DD2E-D – 8 DC Input/6 Sourcing DC Output Micro PLC

Wiring Diagram

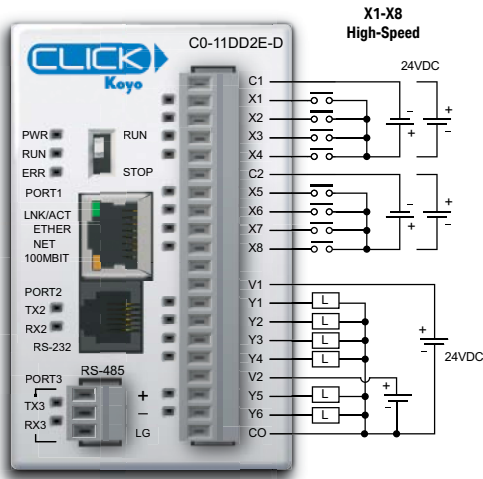

| Built-in I/O Specifications - Inputs | |
|--------------------------------------|----------------------------------|
| Inputs per Module | 8 (Sink/Source) |
| Operating Voltage Range | 24VDC |
| Input Voltage Range | 21.6–26.4 VDC |
| Input Current | Typ 6.5 mA @ 24VDC |
| Maximum Input Current | 7.0 mA @ 26.4 VDC |
| Input Impedance | 3.9 kΩ @ 24VDC |
| Input Frequency (Max) | X1-X8: 100kHz |
| ON Voltage Level | > 19VDC |
| OFF Voltage Level | < 2VDC |
| Minimum ON Current | 4.5 mA |
| Maximum OFF Current | 0.5 mA |
| OFF to ON Response | Typ 3μs Max 5μs |
| ON to OFF Response | Typ 1μs Max 3μs |
| Status Indicators | Logic Side (8 points, green LED) |
| Commons | 2 (4 points/common) Isolated |



NOTE: When using Ethernet Standard PLCs, you must use CLICK programming software version V2.00 or later.

| General Specifications | |
|-------------------------------------|---------------|
| Current Consumption at 24VDC | 140mA |
| Terminal Block Replacement Part No. | C0-16TB |
| Weight | 5.0 oz (140g) |

Equivalent Input Circuit

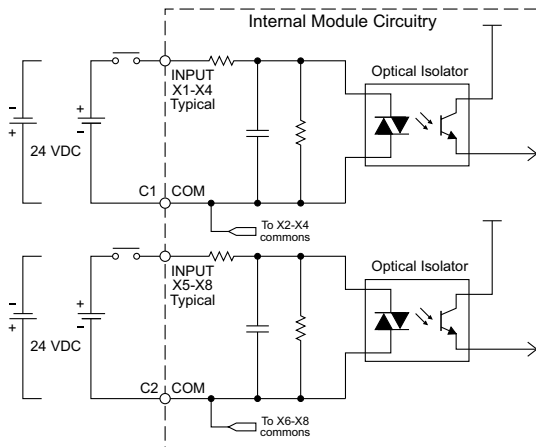

C0-11DD2E-D Temperature Derating Chart

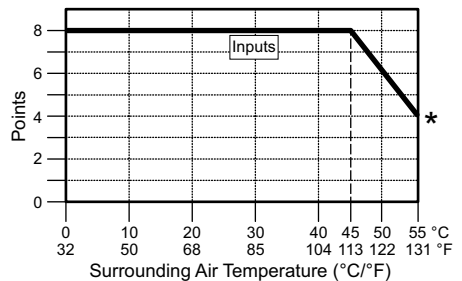

C0-11DD2E-D – 8 DC Input/6 Sourcing DC Output Micro PLC (continued)

| Built-in I/O Specifications - Outputs | |
|---------------------------------------|--------------------------------|
| Outputs per Module | 6 (Source) |
| Operating Voltage Range | 24VDC |
| Output Voltage Range | 19.2-30 VDC |
| Maximum Output Current | 0.1 A/point, 0.6 A/common |
| Minimum Output Current | 0.2 mA |
| Maximum Leakage Current | 0.1 mA @ 30VDC |
| On Voltage Drop | 0.5 VDC @ 0.1 A |
| Maximum Inrush Current | 150mA for 10ms |
| OFF to ON Response | Max. 0.5 ms |
| ON to OFF Response | Max. 0.5 ms |
| Status Indicators | Logic Side (6 points, red LED) |
| Commons | 1 (6 points/common) |

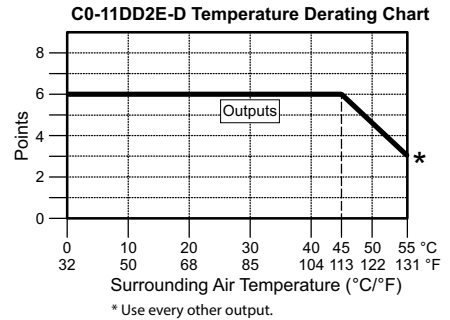

Equivalent Output Circuit

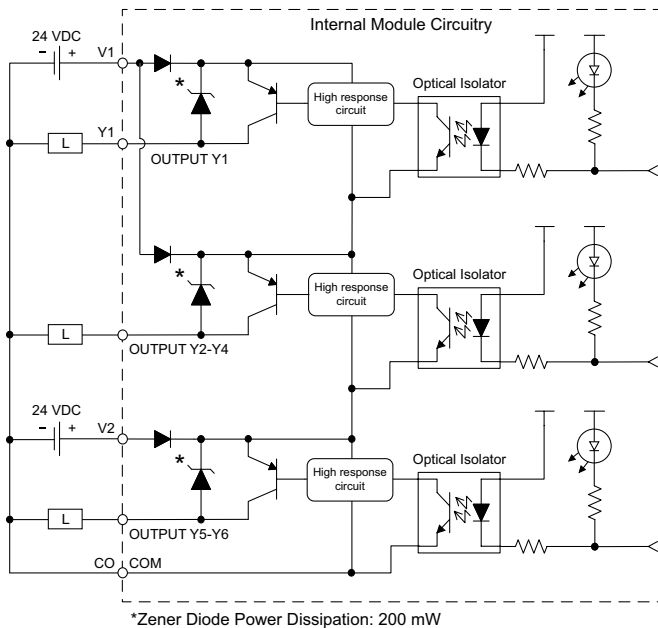

ZIPLink Pre-Wired PLC Connection Cables and Modules for CLICK PLC

- 20-pin connector cable
- ZL-C0-CBL20 (0.5 m length)
- ZL-C0-CBL20-1 (1.0 m length)
- ZL-C0-CBL20-2 (2.0 m length)



- ZL-RTB20
- 20-pin feed-through connector module



C0-11DRE-D – 8 DC Input/6 Relay Output Micro PLC

Wiring Diagram

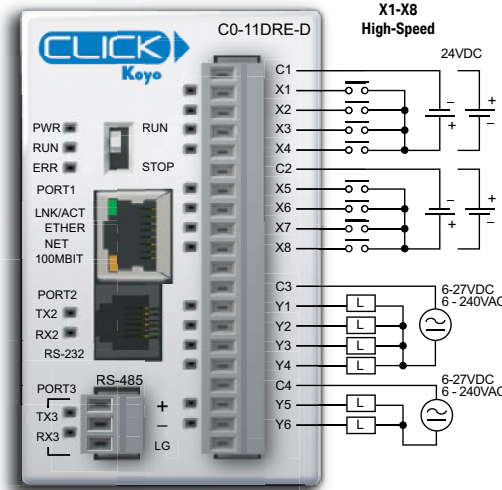

| Built-in I/O Specifications - Inputs | |
|--------------------------------------|----------------------------------|
| Inputs per Module | 8 (Sink/Source) |
| Operating Voltage Range | 24VDC |
| Input Voltage Range | 21.6-26.4 VDC |
| Input Current | Typ 6.5 mA @ 24VDC |
| Maximum Input Current | 7.0 mA @ 26.4 VDC |
| Input Impedance | 3.9 kΩ @ 24VDC |
| Input Frequency (Max) | X1-X8: 100kHz |
| ON Voltage Level | > 19VDC |
| OFF Voltage Level | < 2VDC |
| Minimum ON Current | 4.5 mA |
| Maximum OFF Current | 0.5 mA |
| OFF to ON Response | Typ 3μs Max 5μs |
| ON to OFF Response | Typ 1μs Max 3μs |
| Status Indicators | Logic Side (8 points, green LED) |
| Commons | 2 (4 points/common) Isolated |



NOTE: When using Ethernet Standard PLCs, you must use CLICK programming software version V2.00 or later.

| General Specifications | |
|-------------------------------------|---------------|
| Current Consumption at 24VDC | 140mA |
| Terminal Block Replacement Part No. | C0-16TB |
| Weight | 5.6 oz (160g) |

Equivalent Input Circuit

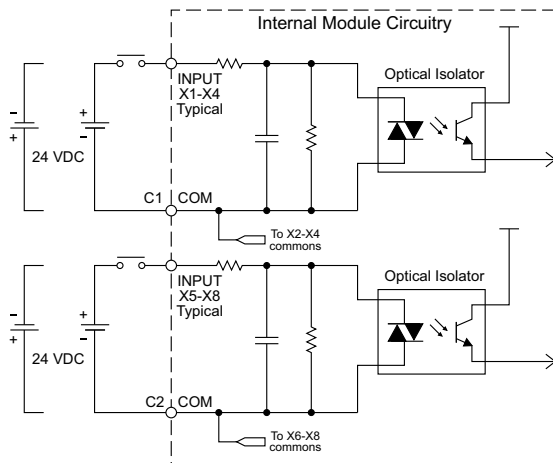

C0-11DRE-D Temperature Derating Chart

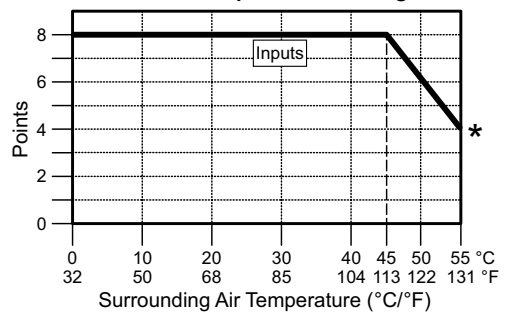

C0-11DRE-D – 8 DC Input/6 Relay Output Micro PLC (continued)

| Built-in I/O Specifications - Outputs | |
|---------------------------------------|--|
| Outputs per Module | 6 |
| Operating Voltage Range | 6-240 VAC (47-63 Hz), 6-27 VDC |
| Output Voltage Range | 5-264 VAC (47-63 Hz), 5-30 VDC |
| Output Type | Relay, form A (SPST) |
| Maximum Current | 1A/point; C3: 4A/common, C4: 2A/common |
| Minimum Load Current | 5mA @ 5VDC |
| Maximum Inrush Current | 3A for 10ms |
| OFF to ON Response | < 15ms |
| ON to OFF Response | < 15ms |
| Status Indicators | Logic Side (6 points, red LED) |
| Commons | 2 (4 points/com & 2 points/com) Isolated |

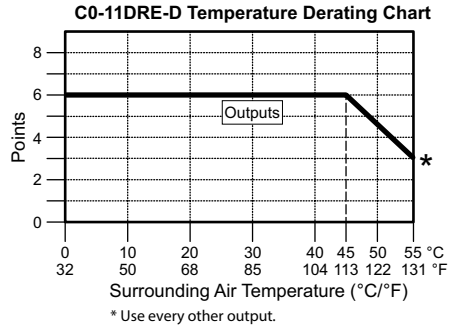

| Typical Relay Life (Operations) at Room Temperature | |
|---|----------------|
| Voltage & Load Type | Relay Life |
| 30VDC, 1A Resistive | 300,000 cycles |
| 30VDC, 1A Solenoid | 50,000 cycles |
| 250VAC, 1A Resistive | 500,000 cycles |
| 250VAC, 1A Solenoid | 200,000 cycles |
| ON to OFF = 1 cycle | |

Equivalent Output Circuit

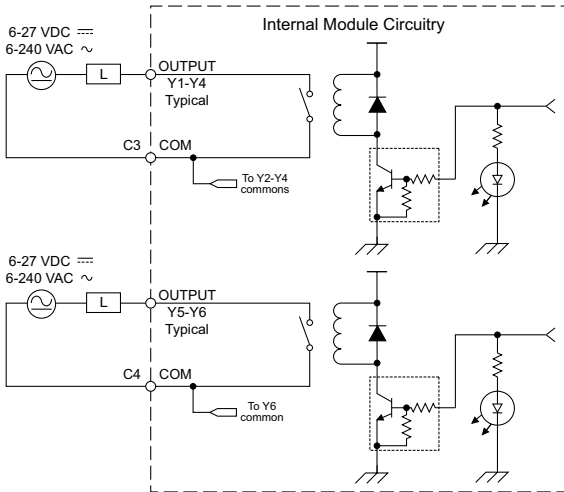

ZIPLink Pre-Wired PLC Connection Cables and Modules for CLICK PLC

- 20-pin connector cable
- ZL-C0-CBL20 (0.5 m length)
- ZL-C0-CBL20-1 (1.0 m length)
- ZL-C0-CBL20-2 (2.0 m length)



ZL-RTB20
20-pin feed-through connector module



NOTE: The C0-11DRE-D is derated to 2A maximum per Common when used with the ZIPLink wiring system.

C0-11ARE-D – 8 AC Input/6 Relay Output Micro PLC

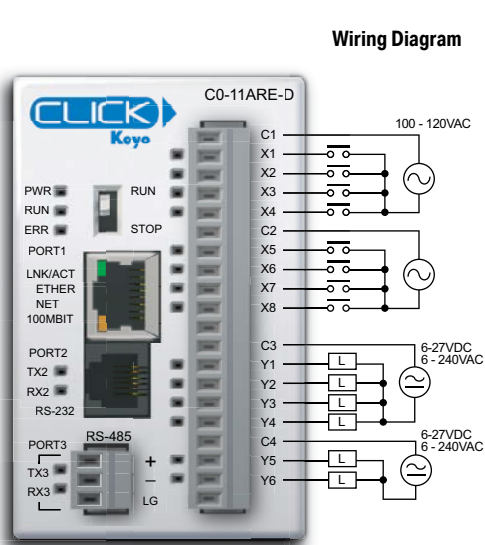

| Built-in I/O Specifications - Inputs | |
|--------------------------------------|--|
| Inputs per Module | 8 |
| Operating Voltage Range | 100-120 VAC |
| Input Voltage Range | 80-144 VAC |
| AC Frequency | 47-63 Hz |
| Input Current | 8.5 mA @ 100VAC at 50Hz 10mA @ 100VAC at 60Hz |
| Maximum Input Current | 16mA @ 144VAC |
| Input Impedance | 15kΩ @ 50Hz 12kΩ @ 60Hz |
| ON Voltage Level | > 60VAC |
| OFF Voltage Level | < 20VAC |
| Minimum ON Current | 5mA |
| Maximum OFF Current | 2mA |
| OFF to ON Response | < 40ms |
| ON to OFF Response | < 40ms |
| Status Indicators | Logic Side (8 points, green LED) |
| Commons | 2 (4 points/common) Isolated |

| General Specifications | |
|-------------------------------------|---------------|
| Current Consumption at 24VDC | 140mA |
| Terminal Block Replacement Part No. | C0-16TB |
| Weight | 5.6 oz (160g) |



NOTE: When using Ethernet Standard PLCs, you must use CLICK programming software version V2.00 or later.

Equivalent Input Circuit

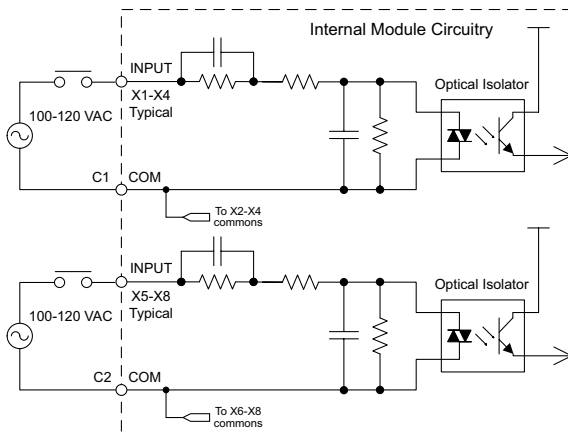

C0-11ARE-D Temperature Derating Chart

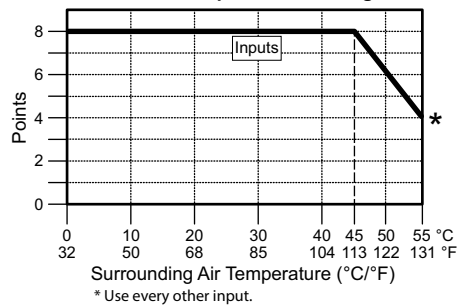

C0-11ARE-D – 8 AC Input/6 Relay Output Micro PLC (continued)

| Built-in I/O Specifications - Outputs | |
|---------------------------------------|---|
| Outputs per Module | 6 |
| Operating Voltage Range | 6–240 VAC (47–63 Hz), 6–27 VDC |
| Output Voltage Range | 5–264 VAC (47–63 Hz), 5–30 VDC |
| Output Type | Relay, form A (SPST) |
| Maximum Current | 1A/point; C3: 4A/common, C4: 2A/common |
| Minimum Load Current | 5mA @ 5 VDC |
| Maximum Inrush Current | 3A for 10ms |
| OFF to ON Response | < 15ms |
| ON to OFF Response | < 15ms |
| Status Indicators | Logic Side (6 points, red LED) |
| Commons | 2 (4 points/com & 2 points/com) Isolated |

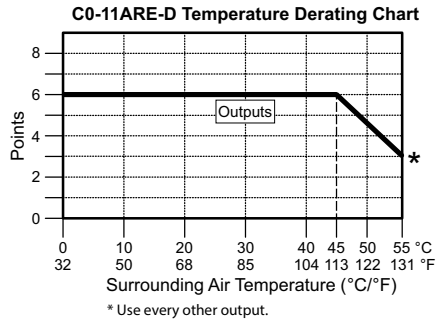

| Typical Relay Life (Operations) at Room Temperature | |
|---|----------------|
| Voltage & Load Type | Relay Life |
| 30VDC, 1A Resistive | 300,000 cycles |
| 30VDC, 1A Solenoid | 50,000 cycles |
| 250VAC, 1A Resistive | 500,000 cycles |
| 250VAC, 1A Solenoid | 200,000 cycles |
| ON to OFF = 1 cycle | |

Equivalent Output Circuit

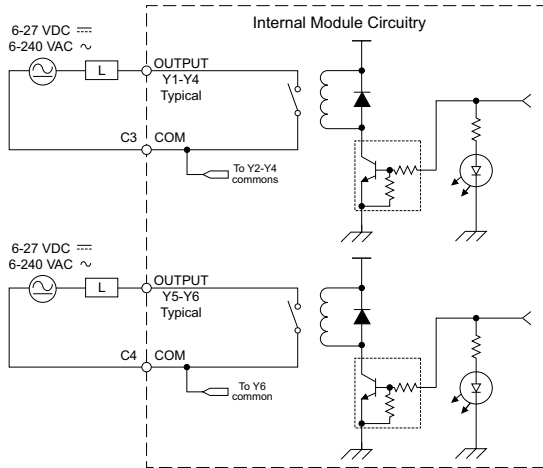

ZIPLink Pre-Wired PLC Connection Cables and Modules for CLICK PLC

- 20-pin connector cable
- ZL-C0-CBL20 (0.5 m length)
- ZL-C0-CBL20-1 (1.0 m length)
- ZL-C0-CBL20-2 (2.0 m length)



ZL-RTB20
20-pin feed-through connector module



NOTE: The C0-11DRE-D is derated to 2A maximum per Common when used with the ZIPLink wiring system.

Ethernet Analog PLC Unit Specifications

C0-12DD1E-D – 4 DC Input (Sink/Source)/4 Sinking DC Output

2 Analog Voltage/Current Input

2 Analog Voltage/Current Output Micro PLC

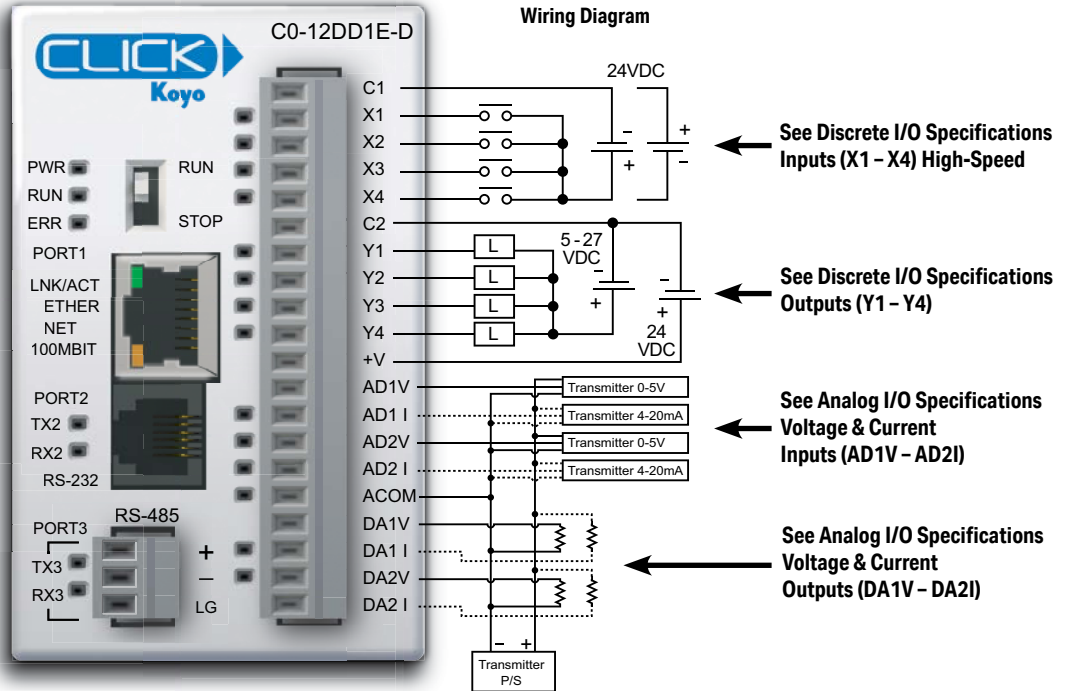

| General Specifications | |
|-------------------------------------|---------------|
| Current Consumption at 24VDC | 140mA |
| Terminal Block Replacement Part No. | C0-16TB |
| Weight | 5.1 oz (145g) |



WARNING: When using an Ethernet Analog PLC unit, you must use CLICK programming software version V2.20 or later.



NOTE: Please refer to the Analog I/O Configuration section in Chapter 3 for information on using the analog I/O.

NOTE: There are no ZIPLink pre-wired PLC connection cables and modules for the Ethernet Analog PLCs (cannot mix discrete I/O and analog I/O signals in a ZIPLink cable).

C0-12DD1E-D (continued)

X1 - X4 (High-Speed)

| Discrete I/O Specifications - Inputs | |
|--------------------------------------|----------------------------------|
| Inputs per Module | 4 (Sink/Source) |
| Operating Voltage Range | 24VDC |
| Input Voltage Range | 21.6-26.4 VDC |
| Input Current | Typ 6.5 mA @ 24VDC |
| Maximum Input Current | 7.0 mA @ 26.4 VDC |
| Input Impedance | 3.9 kΩ @ 24VDC |
| Input Frequency (Max) | X1-X4: 100kHz |
| ON Voltage Level | > 19VDC |
| OFF Voltage Level | < 2VDC |
| Minimum ON Current | 4.5 mA |
| Maximum OFF Current | 0.5 mA |
| OFF to ON Response | Typ 3μs Max 5μs |
| ON to OFF Response | Typ 1μs Max 3μs |
| Status Indicators | Logic Side (4 points, green LED) |
| Commons | 1 (4 points/common) |

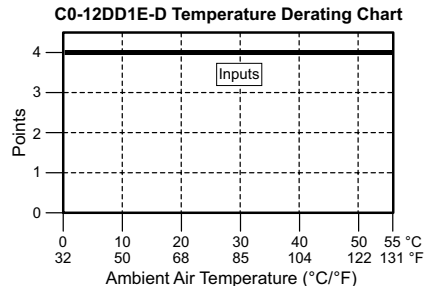
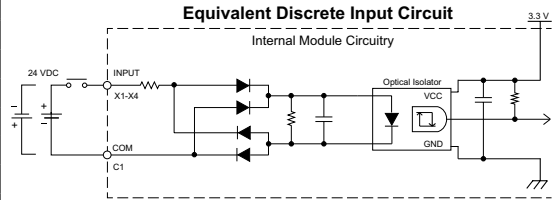

Y1 - Y4

| Discrete I/O Specifications - Outputs | |
|---------------------------------------|--|
| Outputs per Module | 4 (Sink) |
| Operating Voltage Range | 5-27 VDC |
| Maximum Output Current | 0.1 A/point; 0.4 A/common |
| Minimum Output Current | 0.2 mA |
| Maximum Leakage Current | 0.1 mA @ 30.0 VDC |
| On Voltage Drop | 0.5 VDC @ 0.1 A |
| Maximum Inrush Current | 150mA for 10ms |
| OFF to ON Response | < 5μs |
| ON to OFF Response | < 5μs |
| Status Indicators | Logic Side (4 points, red LED) |
| Commons | 1 (4 points/common) |
| External DC Power Required | 20-28 VDC Maximum @ 60mA (All points ON) |

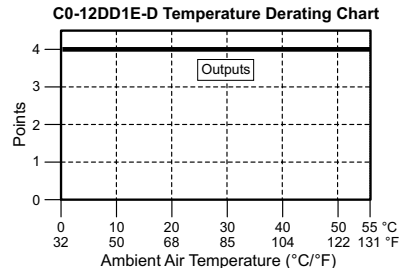
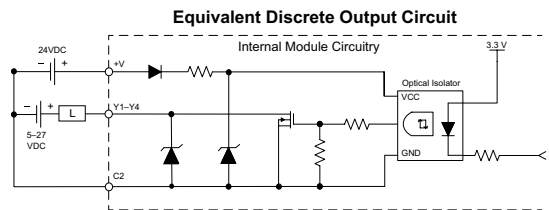

C0-12DD1E-D (continued)

AD1V - AD2I

| Analog Specifications - Voltage Input | |
|---------------------------------------|--------------------------------|
| Inputs per Module | 2 (voltage/current selectable) |
| Input Range | 0-5 VDC (6VDC Max.) |
| Resolution | 12-bit |
| Conversion Time | 50ms |
| Input Impedance | 20kΩ |
| Input Stability | ±2 LSB maximum |
| Full-Scale Calibration Error | ±2% maximum |
| Offset Calibration Error | ±25mV maximum |
| Accuracy vs. Temperature Error | ±100ppm / °C maximum |

| Analog Specifications - Current Input | |
|---------------------------------------|--------------------------------|
| Inputs per Module | 2 (voltage/current selectable) |
| Input Range | 4-20 mA (sink) |
| Resolution | 12-bit |
| Conversion Time | 50ms |
| Input Impedance | 125Ω |
| Input Stability | ±2 LSB maximum |
| Full-Scale Calibration Error | ±2% maximum |
| Offset Calibration Error | ±0.1 mA maximum |
| Accuracy vs. Temperature Error | ±100ppm / °C maximum |

Analog Voltage Input Circuit

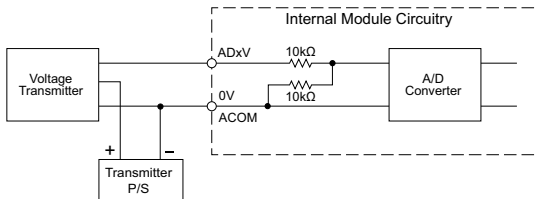

Analog Current Input Circuit

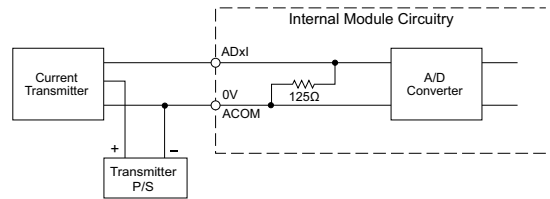

DA1V - DA2I

| Analog Specifications - Voltage Output | |
|--|---|
| Outputs per Module | 2 (voltage/current selectable) |
| Output Range | 0-5 VDC |
| Resolution | 12-bit |
| Conversion Time | 1ms |
| Load Impedance | 2kΩ minimum (output current 2.5 mA maximum) |
| Full-Scale Calibration Error | ±2% maximum |
| Offset Calibration Error | ±25mV maximum |
| Accuracy vs. Temperature Error | ±100ppm / °C maximum |

| Analog Specifications - Current Output | |
|--|---|
| Outputs per Module | 2 (voltage/current selectable) |
| Output Range | 4-20 mA (sink) |
| Resolution | 12-bit |
| Conversion Time | 1ms |
| Loop Supply Voltage | DC 18-30 V |
| Load Impedance | 250Ω Load Power Supply: DC 18V: 600Ω maximum DC 24V: 900Ω maximum DC 30V: 1200Ω maximum |
| Full-Scale Calibration Error | ±2% maximum |
| Offset Calibration Error | ±25mA maximum |
| Accuracy vs. Temperature Error | ±100ppm / °C maximum |

Analog Voltage Output Circuit

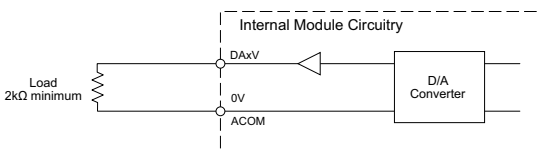

Analog Current Output Circuit

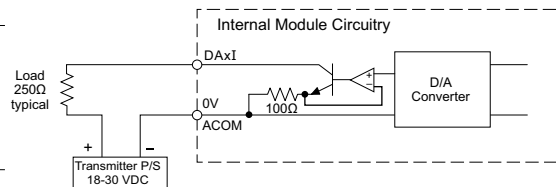

**C0-12DD2E-D – 4 DC Input (Sink/Source)/4 Sourcing DC Output;
2 Analog Voltage/Current Input
2 Analog Voltage/Current Output Micro PLC**

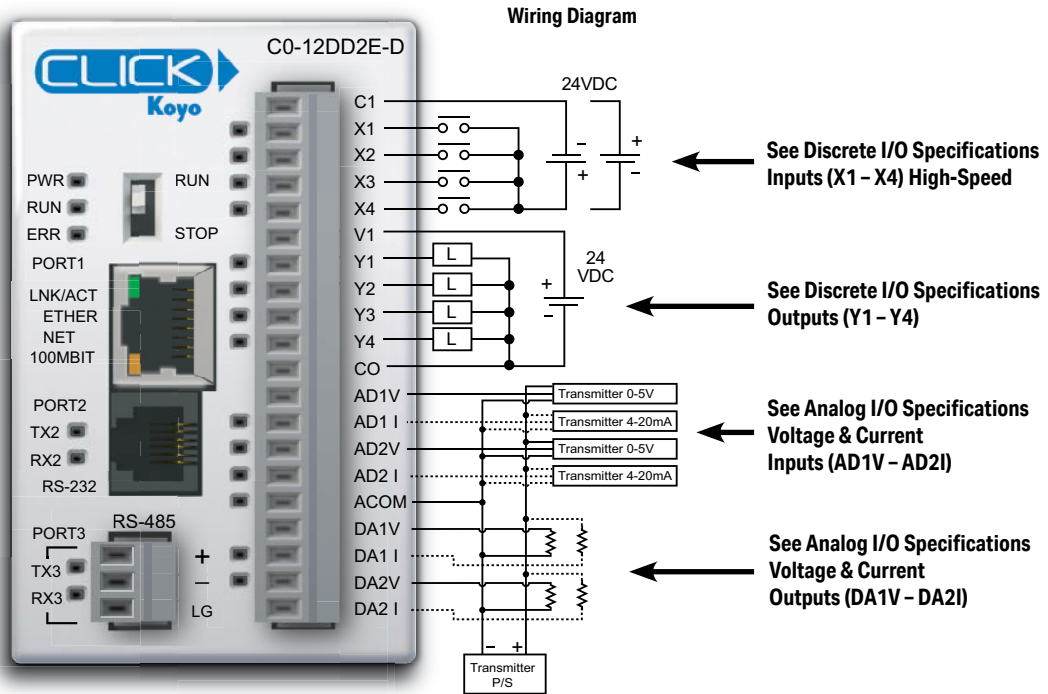

| General Specifications | |
|-------------------------------------|----------------|
| Current Consumption at 24VDC | 140mA |
| Terminal Block Replacement Part No. | C0-16TB |
| Weight | 5.08 oz (144g) |



WARNING: When using an Ethernet Analog PLC unit, you must use CLICK programming software version V2.20 or later.

NOTE: Please refer to the Analog I/O Configuration section in Chapter 3 for information on using the analog I/O.



NOTE: There are no ZIPLink pre-wired PLC connection cables and modules for the Ethernet Analog PLCs (cannot mix discrete I/O and analog I/O signals in a ZIPLink cable).

C0-12DD2E-D (continued)

X1 - X4 (High-Speed)

| Discrete I/O Specifications - Inputs | |
|--------------------------------------|----------------------------------|
| Inputs per Module | 4 (Sink/Source) |
| Operating Voltage Range | 24VDC |
| Input Voltage Range | 21.6–26.4 VDC |
| Input Current | Typ 6.5 mA @ 24VDC |
| Maximum Input Current | 7mA @ 26.4 VDC |
| Input Impedance | 3.9 kΩ @ 24VDC |
| Input Frequency (Max) | X1-X4: 100kHz |
| ON Voltage Level | > 19VDC |
| OFF Voltage Level | < 2VDC |
| Minimum ON Current | 4.5 mA |
| Maximum OFF Current | 0.5 mA |
| OFF to ON Response | Typ 3μs, Max 5μs |
| ON to OFF Response | Typ 1μs, Max 3μs |
| Status Indicators | Logic Side (4 points, green LED) |
| Commons | 1 (4 points/common) |

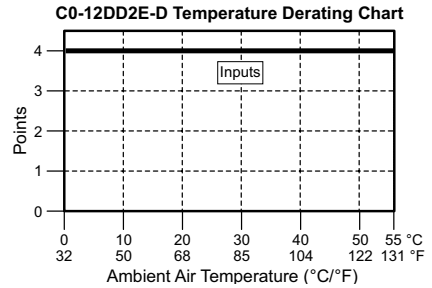
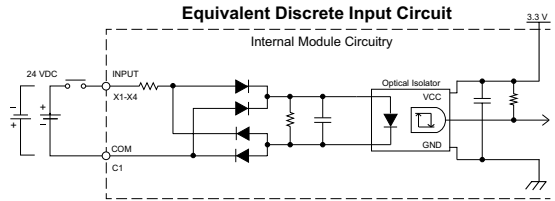

Y1 - Y4

| Discrete I/O Specifications - Outputs | |
|---------------------------------------|--------------------------------|
| Outputs per Module | 4 (Source) |
| Operating Voltage Range | 24VDC |
| Output Voltage Range | 19.2–30 VDC |
| Maximum Output Current | 0.1 A/point , 0.4 A/common |
| Minimum Output Current | 0.2 mA |
| Maximum Leakage Current | 0.1mA @ 30VDC |
| On Voltage Drop | 0.5 VDC@ 0.1 A |
| Maximum Inrush Current | 150mA for 10ms |
| OFF to ON Response | < 5μs |
| ON to OFF Response | < 5μs |
| Status Indicators | Logic Side (4 points, red LED) |
| Commons | 1 (4 points/common) |

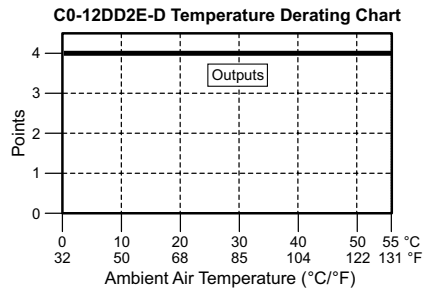
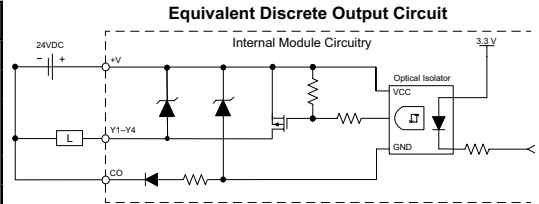

C0-12DD2E-D (continued)

AD1V - AD2I

| Analog Specifications - Voltage Input | |
|---------------------------------------|--------------------------------|
| Inputs per Module | 2 (voltage/current selectable) |
| Input Range | 0-5 VDC |
| Resolution | 12-bit |
| Conversion Time | 50ms |
| Input Impedance | 20kΩ |
| Input Stability | ±2 LSB maximum |
| Full-Scale Calibration Error | ±2% maximum |
| Offset Calibration Error | ±25mV maximum |
| Accuracy vs. Temperature Error | ±100ppm / °C maximum |

Analog Voltage Input Circuit

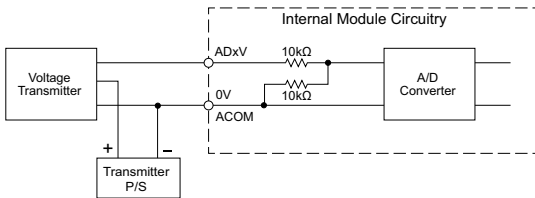

| Analog Specifications - Current Input | |
|---------------------------------------|--------------------------------|
| Inputs per Module | 2 (voltage/current selectable) |
| Input Range | 4-20 mA (sink) |
| Resolution | 12-bit |
| Conversion Time | 50ms |
| Input Impedance | 125Ω |
| Input Stability | ±2 LSB maximum |
| Full-Scale Calibration Error | ±2% maximum |
| Offset Calibration Error | ±0.1 mA maximum |
| Accuracy vs. Temperature Error | Less than ±100ppm / °C |

Analog Current Input Circuit

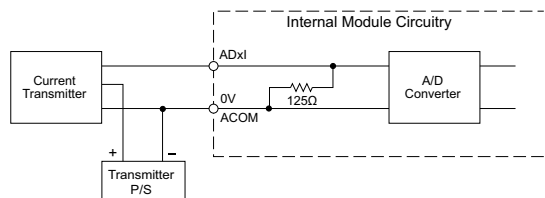

DA1V - DA2I

| Analog Specifications - Voltage Output | |
|--|---|
| Outputs per Module | 2 (voltage/current selectable) |
| Output Range | 0-5 VDC |
| Resolution | 12-bit |
| Conversion Time | 1ms |
| Load Impedance | 2kΩ minimum (output current 2.5 mA maximum) |
| Full-Scale Calibration Error | ±2% maximum |
| Offset Calibration Error | ±25mV maximum |
| Accuracy vs. Temperature Error | ±100ppm / °C maximum |

Analog Voltage Output Circuit

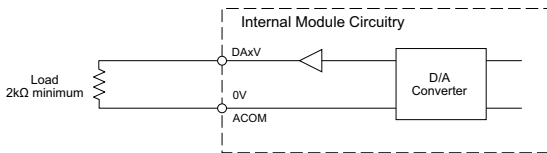

| Analog Specifications - Current Output | |
|--|---|
| Outputs per Module | 2 (voltage/current selectable) |
| Output Range | 4-20 mA (sink) |
| Resolution | 12-bit |
| Conversion Time | 1ms |
| Loop Supply Voltage | DC 18-30 V |
| Load Impedance | 250Ω Load Power Supply: DC 18V: 600Ω maximum DC 24V: 900Ω maximum DC 30V: 1200Ω maximum |
| Full-Scale Calibration Error | ±2% maximum |
| Offset Calibration Error | ±25mA maximum |
| Accuracy vs. Temperature Error | ±100ppm / °C maximum |

Analog Current Output Circuit

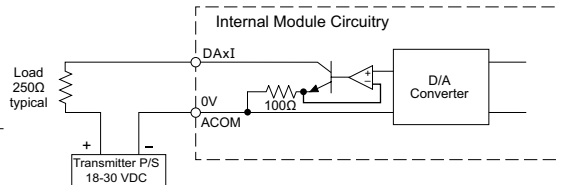

C0-12DRE-D – 4 DC Input (Sink/Source)/4 Relay Output;

2 Analog Voltage/Current Input

2 Analog Voltage/Current Output Micro PLC

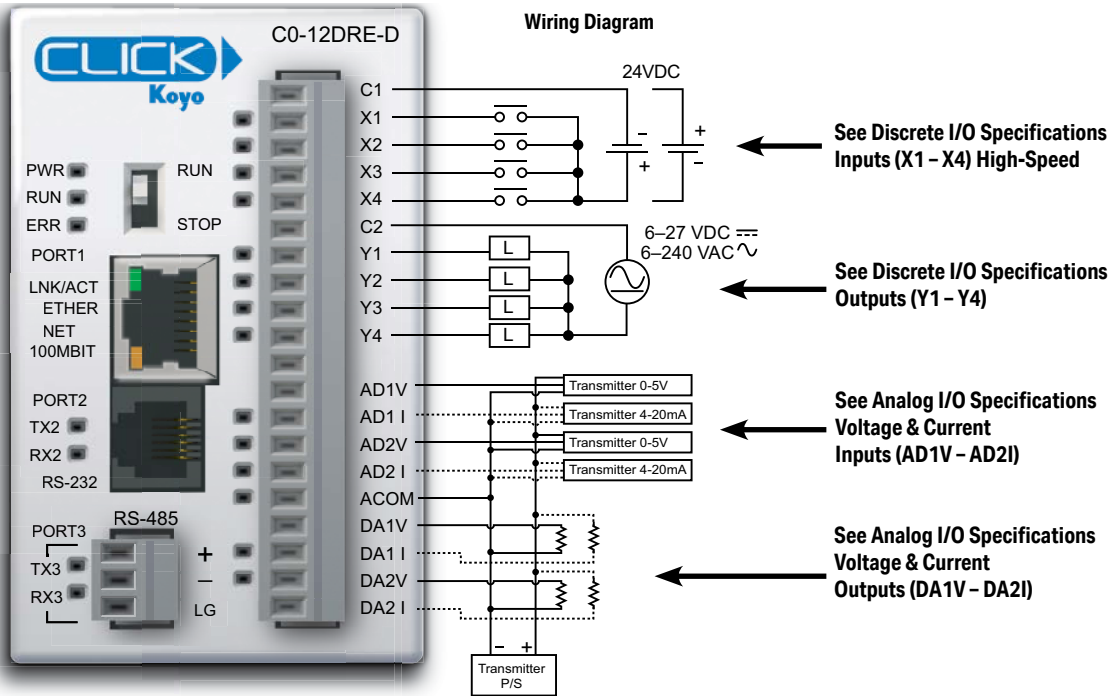

| General Specifications | |
|-------------------------------------|---------------|
| Current Consumption at 24VDC | 160mA |
| Terminal Block Replacement Part No. | C0-16TB |
| Weight | 5.4 oz (155g) |



WARNING: When using an Ethernet Analog PLC unit, you must use CLICK programming software version V2.20 or later.

NOTE: Please refer to the Analog I/O Configuration section in Chapter 3 for information on using the analog I/O.



NOTE: There are no ZIPLink pre-wired PLC connection cables and modules for the Ethernet Analog PLCs (cannot mix discrete I/O and analog I/O signals in a ZIPLink cable).

C0-12DRE-D (continued)

X1 - X4 (High-Speed)

| Discrete I/O Specifications - Inputs | |
|--------------------------------------|----------------------------------|
| Inputs per Module | 4 (Source/Sink) |
| Operating Voltage Range | 24VDC |
| Input Voltage Range | 21.6-26.4 VDC |
| Input Current | Typ 6.5 mA @ 24VDC |
| Input Impedance | 3.9 kΩ @ 24 VDC |
| Input Frequency (Max) | X1-X4: 100kHz |
| ON Voltage Level | > 19VDC |
| OFF Voltage Level | < 2VDC |
| Minimum ON Current | 4.5 mA |
| Maximum OFF Current | 0.5 mA |
| OFF to ON Response | Typ 3μs, Max 5μs |
| ON to OFF Response | Typ 1μs, Max 3μs |
| Status Indicators | Logic Side (4 points, green LED) |
| Commons | 1 (4 points/common) |

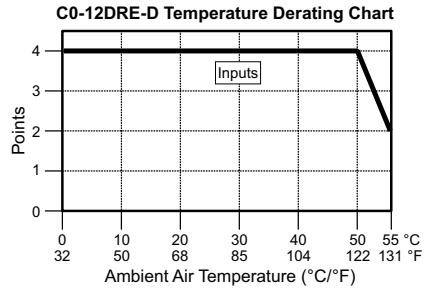
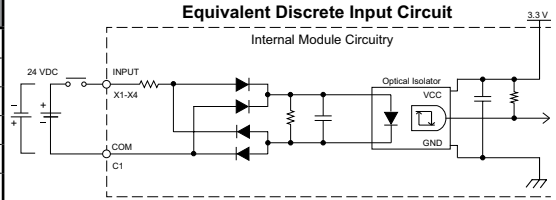

Y1 - Y4

| Discrete I/O Specifications - Outputs | |
|---------------------------------------|--------------------------------|
| Outputs per Module | 4 |
| Operating Voltage Range | 6-27 VDC / 6-240 VAC |
| Output Type | Relay, form A (SPST) |
| AC Frequency | 47-63 Hz |
| Maximum Current | 1A/point (resistive) |
| Minimum Load Current | 5mA @ 5VDC |
| Maximum Inrush Current | 3A for 10ms |
| OFF to ON Response | < 15ms |
| ON to OFF Response | < 15ms |
| Status Indicators | Logic Side (4 points, red LED) |
| Commons per Module | 1 (4 points/common) |

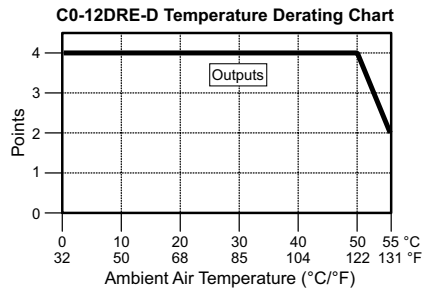
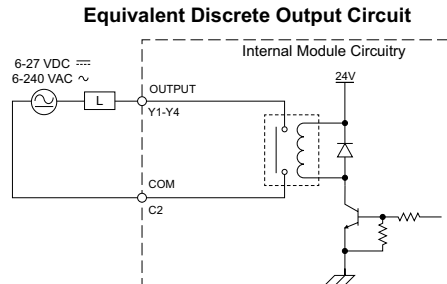

| Typical Relay Life (Operations) at Room Temperature | |
|---|----------------|
| Voltage & Load Type | Relay Life |
| 30VDC, 1A Resistive | 300,000 cycles |
| 30VDC, 1A Solenoid | 50,000 cycles |
| 120VAC, 1A Resistive | 500,000 cycles |
| 120VAC, 1A Solenoid | 200,000 cycles |
| ON to OFF = 1 cycle | |

C0-12DRE-D (continued)

AD1V - AD2I

| Analog Specifications - Voltage Input | |
|---------------------------------------|--------------------------------|
| Inputs per Module | 2 (voltage/current selectable) |
| Input Range | 0-5 VDC (6VDC Max.) |
| Resolution | 12-bit |
| Conversion Time | 50ms |
| Input Impedance | 20kΩ |
| Input Stability | ±2 LSB maximum |
| Full-Scale Calibration Error | ±2% maximum |
| Offset Calibration Error | ±25mV maximum |
| Accuracy vs. Temperature Error | ±100ppm / °C maximum |

| Analog Specifications - Current Input | |
|---------------------------------------|--------------------------------|
| Inputs per Module | 2 (voltage/current selectable) |
| Input Range | 4-20 mA (sink) |
| Resolution | 12-bit |
| Conversion Time | 50ms |
| Input Impedance | 125Ω |
| Input Stability | ±2 LSB maximum |
| Full-Scale Calibration Error | ±2% maximum |
| Offset Calibration Error | ±0.1 mA maximum |
| Accuracy vs. Temperature Error | ±100ppm / °C maximum |

Analog Voltage Input Circuit

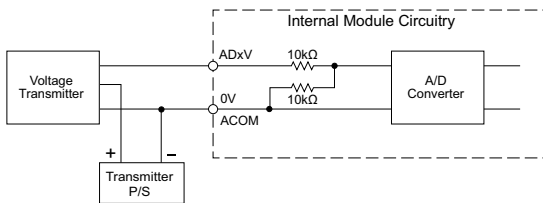

Analog Current Input Circuit

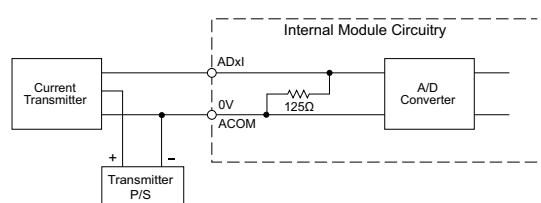

DA1V - DA2I

| Analog Specifications - Voltage Output | |
|--|---|
| Outputs per Module | 2 (voltage/current selectable) |
| Output Range | 0-5 VDC |
| Resolution | 12-bit |
| Conversion Time | 1ms |
| Load Impedance | 2kΩ minimum (output current 2.5 mA maximum) |
| Full-Scale Calibration Error | ±2% maximum |
| Offset Calibration Error | ±25mV maximum |
| Accuracy vs. Temperature Error | ±100ppm / °C maximum |

| Analog Specifications - Current Output | |
|--|---|
| Outputs per Module | 2 (voltage/current selectable) |
| Output Range | 4-20 mA (sink) |
| Resolution | 12-bit |
| Conversion Time | 1ms |
| Loop Supply Voltage | DC 18-30 V |
| Load Impedance | 250Ω Load Power Supply: DC 18V: 600Ω maximum DC 24V: 900Ω maximum DC 30V: 1200Ω maximum |
| Full-Scale Calibration Error | ±2% maximum |
| Offset Calibration Error | ±25mA maximum |
| Accuracy vs. Temperature Error | ±100ppm / °C maximum |

Analog Voltage Output Circuit

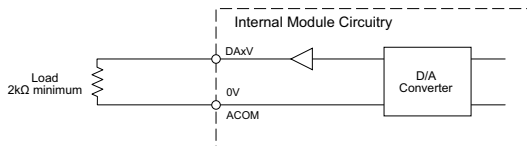

Analog Current Output Circuit

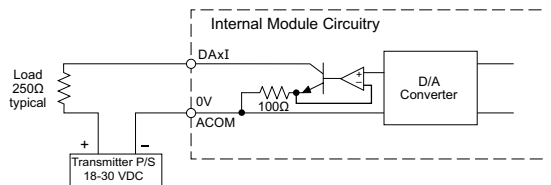

C0-12ARE-D – 4 AC Input/4 Relay Output;

2 Analog Voltage/Current Input

2 Analog Voltage/Current Output Micro PLC

Wiring Diagram

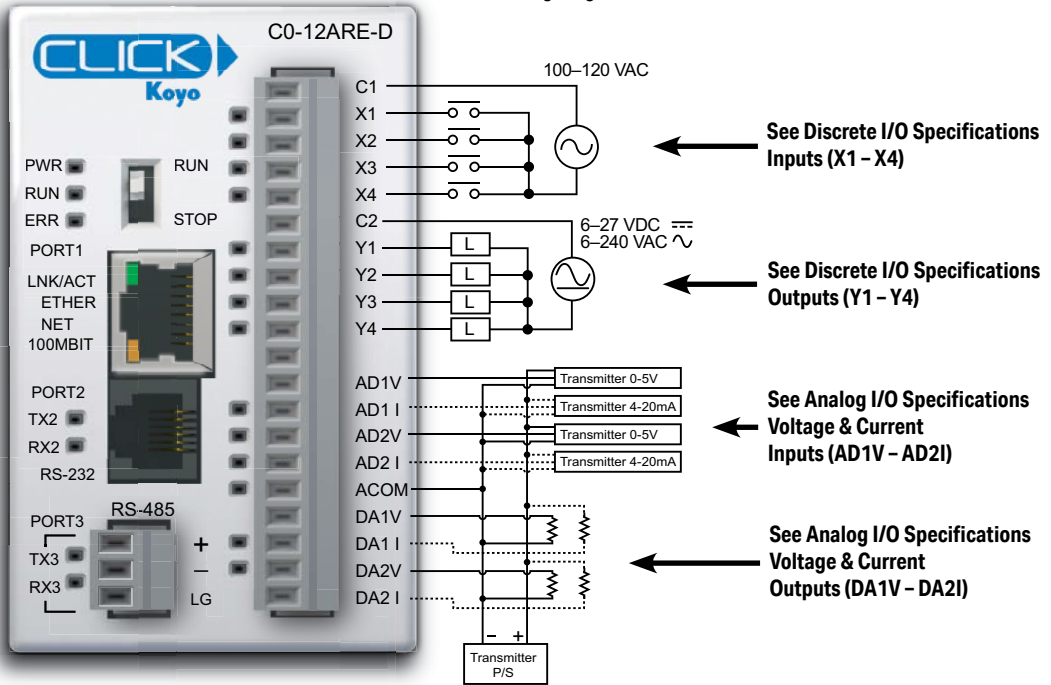

| General Specifications | |
|-------------------------------------|---------------|
| Current Consumption at 24VDC | 160mA |
| Terminal Block Replacement Part No. | C0-16TB |
| Weight | 5.4 oz (154g) |



WARNING: When using an Ethernet Analog PLC unit, you must use CLICK programming software version V2.20 or later.

NOTE: Please refer to the Analog I/O Configuration section in Chapter 3 for information on using the analog I/O.



NOTE: There are no ZIPLink pre-wired PLC connection cables and modules for the Ethernet Analog PLCs (cannot mix discrete I/O and analog I/O signals in a ZIPLink cable).

C0-12ARE-D (continued)

X1 - X4

| Discrete I/O Specifications - Inputs | |
|--------------------------------------|---|
| Inputs per Module | 4 |
| Operating Voltage Range | 100-120 VAC |
| AC Frequency | 47-63 Hz |
| Input Current | Typ 8.5 mA @ 100VAC (50Hz) Typ 10mA @100VAC (60Hz) |
| Max. Input Current | 16mA @ 144VAC |
| Input Impedance | 15kΩ @ 50Hz 12kΩ @ 60Hz |
| ON Voltage Level | > 60VAC |
| OFF Voltage Level | < 20VAC |
| Minimum ON Current | 5mA |
| Maximum OFF Current | 2mA |
| OFF to ON Response | < 40ms |
| ON to OFF Response | < 40ms |
| Status Indicators | Logic Side (4 points, green LED) |
| Commons | 1 (4 points/common) |

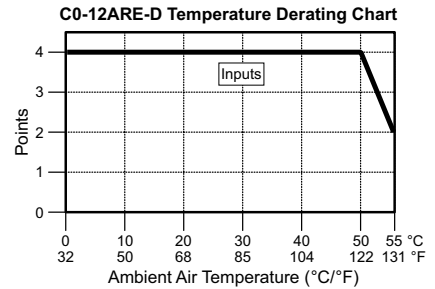
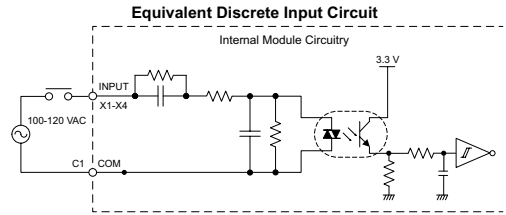

Y1 - Y4

| Discrete I/O Specifications - Outputs | |
|---------------------------------------|--------------------------------|
| Outputs per Module | 4 |
| Operating Voltage Range | 6-27 VDC, 6-240 VAC |
| Output Type | Relay, form A (SPST) |
| AC Frequency | 47-63 Hz |
| Maximum Current | 1A/point (resistive) |
| Minimum Load Current | 5mA @ 5VDC |
| Maximum Inrush Current | 3A for 10ms |
| OFF to ON Response | < 15ms |
| ON to OFF Response | < 15ms |
| Status Indicators | Logic Side (4 points, red LED) |
| Commons per Module | 1 (4 points/common) |

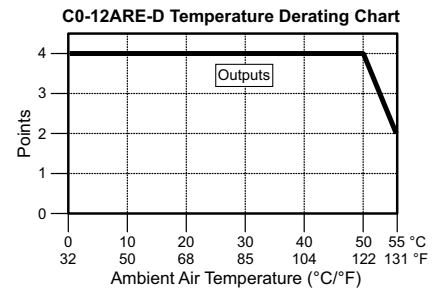
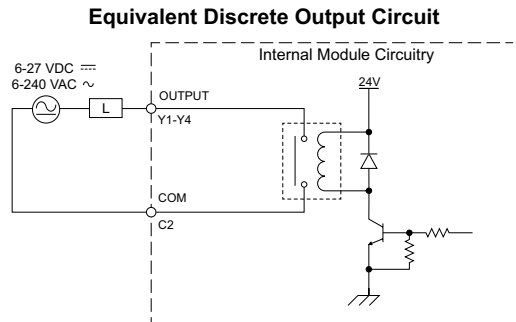

| Typical Relay Life (Operations) at Room Temperature | |
|---|----------------|
| Voltage & Load Type | Relay Life |
| 30VDC, 1A Resistive | 300,000 cycles |
| 30VDC, 1A Solenoid | 50,000 cycles |
| 120VAC, 1A Resistive | 500,000 cycles |
| 120VAC, 1A Solenoid | 200,000 cycles |

ON to OFF = 1 cycle

C0-12ARE-D (continued)

AD1V - AD2V

| Analog Specifications - Voltage Input | |
|---------------------------------------|--------------------------------|
| Inputs per Module | 2 (voltage/current selectable) |
| Input Range | 0–5 VDC (6VDC Max.) |
| Resolution | 12-bit |
| Conversion Time | 50ms |
| Input Impedance | 20kΩ |
| Input Stability | ±2 LSB maximum |
| Full-Scale Calibration Error | ±2% maximum |
| Offset Calibration Error | ±25mV maximum |
| Accuracy vs. Temperature Error | ±100ppm / °C maximum |

Analog Voltage Input Circuit

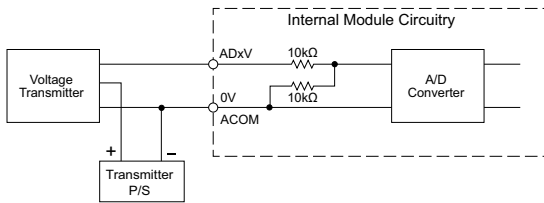

AD1I - AD2I

| Analog Specifications - Current Input | |
|---------------------------------------|--------------------------------|
| Inputs per Module | 2 (voltage/current selectable) |
| Input Range | 4–20 mA (sink) |
| Resolution | 12-bit |
| Conversion Time | 50ms |
| Input Impedance | 125Ω |
| Input Stability | ±2 LSB maximum |
| Full-Scale Calibration Error | ±2% maximum |
| Offset Calibration Error | ±0.1 mA maximum |
| Accuracy vs. Temperature Error | ±100ppm / °C maximum |

Analog Current Input Circuit

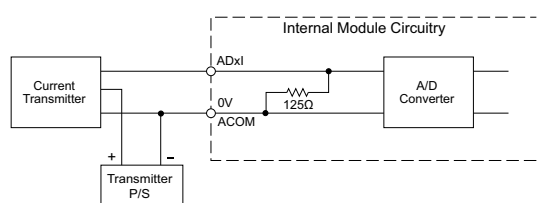

DA1V - DA2V

| Analog Specifications - Voltage Output | |
|--|---|
| Outputs per Module | 2 (voltage/current selectable) |
| Output Range | 0–5 VDC |
| Resolution | 12-bit |
| Conversion Time | 1ms |
| Load Impedance | 2kΩ minimum (output current 2.5 mA maximum) |
| Full-Scale Calibration Error | ±2% maximum |
| Offset Calibration Error | ±25mV maximum |
| Accuracy vs. Temperature Error | ±100ppm / °C maximum |

Analog Voltage Output Circuit

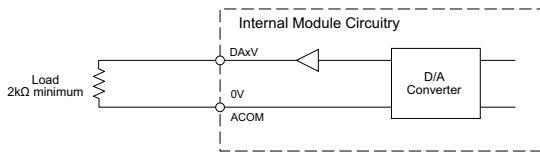

DA1I - DA2I

| Analog Specifications - Current Output | |
|--|---|
| Outputs per Module | 2 (voltage/current selectable) |
| Output Range | 4–20 mA (sink) |
| Resolution | 12-bit |
| Conversion Time | 1ms |
| Loop Supply Voltage | DC 18–30 V |
| Load Impedance | 250Ω Load Power Supply: DC 18V: 600Ω maximum DC 24V: 900Ω maximum DC 30V: 1200Ω maximum |
| Full-Scale Calibration Error | ±2% maximum |
| Offset Calibration Error | ±25mA maximum |
| Accuracy vs. Temperature Error | ±100ppm / °C maximum |

Analog Current Output Circuit

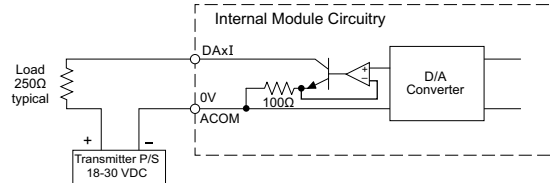

**C0-12DD1E-1-D – 4 DC Input (Sink/Source)/4 Sinking DC Output;
4 Analog Current Input
2 Analog Current Output Micro PLC**

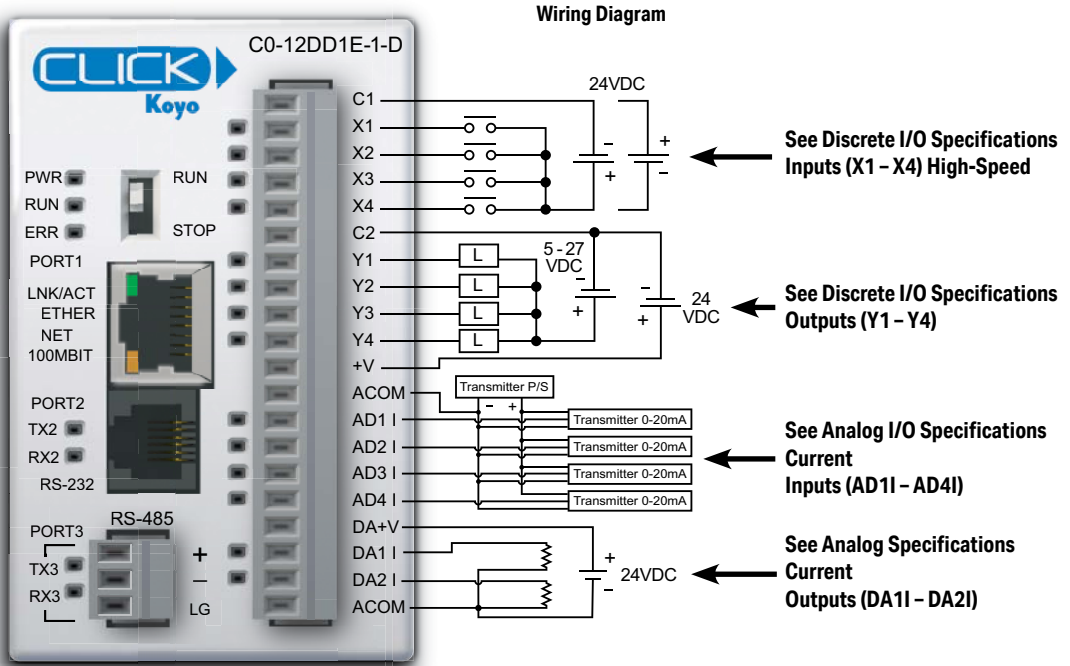

| General Specifications | |
|-------------------------------------|----------------|
| Current Consumption at 24VDC | 140mA |
| Terminal Block Replacement Part No. | C0-16TB |
| Weight | 5.08 oz (144g) |



WARNING: When using an Ethernet Analog PLC unit, you must use CLICK programming software version V2.20 or later.

NOTE: Please refer to the Analog I/O Configuration section in Chapter 3 for information on using the analog I/O.



NOTE: There are no ZIPLink pre-wired PLC connection cables and modules for the Ethernet Analog PLCs (cannot mix discrete I/O and analog I/O signals in a ZIPLink cable).

C0-12DD1E-1-D (continued)

X1 - X4 (High-Speed)

| Discrete I/O Specifications - Inputs | |
|--------------------------------------|----------------------------------|
| Inputs per Module | 4 (Sink/Source) |
| Operating Voltage Range | 24VDC |
| Input Voltage Range | 21.6-26.4 VDC |
| Input Current | Typ 6.5 mA @ 24VDC |
| Maximum Input Current | 7mA @ 26.4 VDC |
| Input Impedance | 3.9 kΩ @ 24VDC |
| Input Frequency (Max) | X1-X4: 100kHz |
| ON Voltage Level | >19VDC |
| OFF Voltage Level | < 2VDC |
| Minimum ON Current | 4.5 mA |
| Maximum OFF Current | 0.5 mA |
| OFF to ON Response | Typ 3μs Max 5μs |
| ON to OFF Response | Typ 1μs Max 3μs |
| Status Indicators | Logic Side (4 points, green LED) |
| Commons | 1 (4 points/common) |

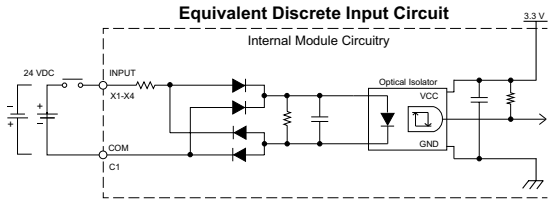

C0-12DD1E-1-D Temperature Derating Chart

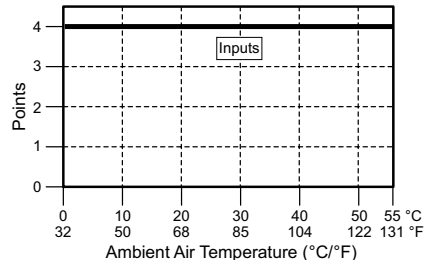

Y1 - Y4

| Discrete I/O Specifications - Outputs | |
|---------------------------------------|--|
| Outputs per Module | 4 (Sink) |
| Operating Voltage Range | 5-27 VDC |
| Maximum Output Current | 0.1 A/point; 0.4 A/common |
| Minimum Output Current | 0.2 mA |
| Maximum Leakage Current | 0.1 mA @ 30.0 VDC |
| On Voltage Drop | 0.5 VDC @ 0.1 A |
| Maximum Inrush Current | 150mA for 10ms |
| OFF to ON Response | < 5μs |
| ON to OFF Response | < 5μs |
| Status Indicators | Logic Side (4 points, red LED) |
| Commons | 1 (4 points/common) |
| External DC Power Required | 20-28 VDC Maximum @ 60mA (All points on) |

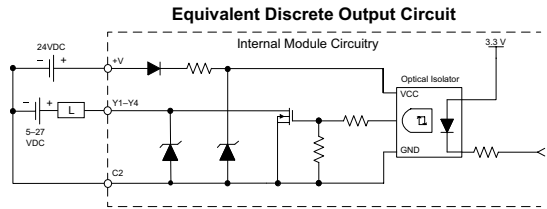

C0-12DD1E-1-D Temperature Derating Chart

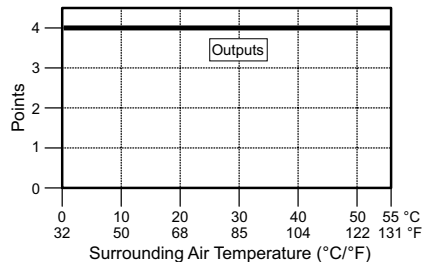

C0-12DD1E-1-D (continued)

AD1I - AD4I

| Analog Specifications - Current Input | |
|---------------------------------------|----------------------|
| Inputs per Module | 4 (current) |
| Input Range | 0-20 mA (sink) |
| Resolution | 12-bit |
| Conversion Time | 50ms |
| Input Impedance | 125Ω |
| Input Stability | ±2 LSB maximum |
| Full-Scale Calibration Error | ±2% maximum |
| Offset Calibration Error | ±0.1 mA maximum |
| Accuracy vs. Temperature Error | ±120ppm / °C maximum |

Analog Current Input Circuit

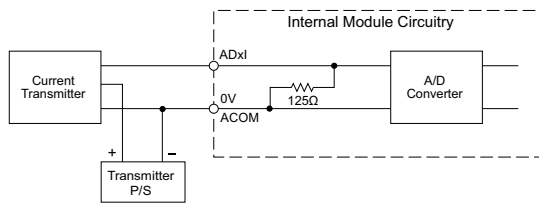

DA1I - DA2I

| Analog Specifications - Current Output | |
|--|----------------------------|
| Outputs per Module | 2 (current) |
| Output Range | 4-20 mA (source) |
| Resolution | 12-bit |
| Conversion Time | 2.5 ms |
| Load Impedance | 250Ω TYP (200-800 Ω) |
| Loop Supply Voltage | DC 24V TYP (21.6-26.4 VDC) |
| Full-Scale Calibration Error | ±2% maximum |
| Offset Calibration Error | ±25mA maximum |
| Accuracy vs. Temperature Error | ±120ppm / °C maximum |
| External DC Power Required | 21.6-26.4 VDC |

Analog Current Output Circuit

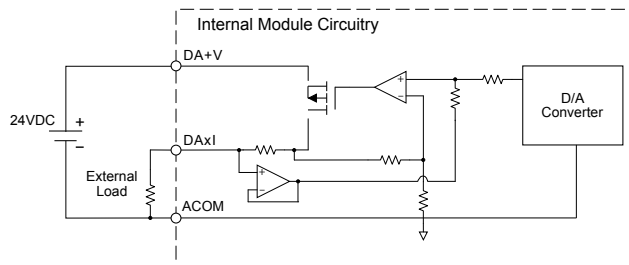

**C0-12DD2E-1-D – 4 DC Input (Sink/Source)/4 Sourcing DC Output;
4 Analog Current Input
2 Analog Current Output Micro PLC**

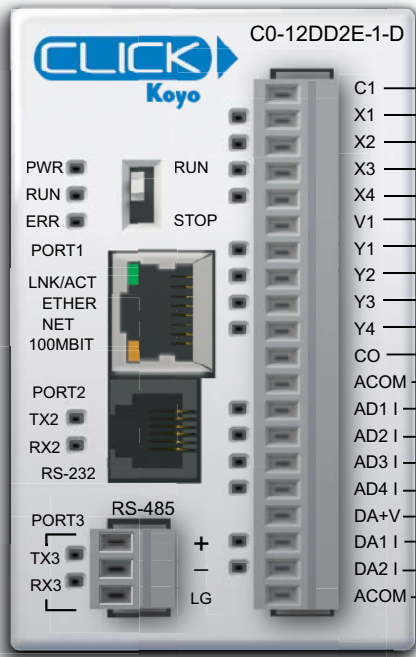

Wiring Diagram

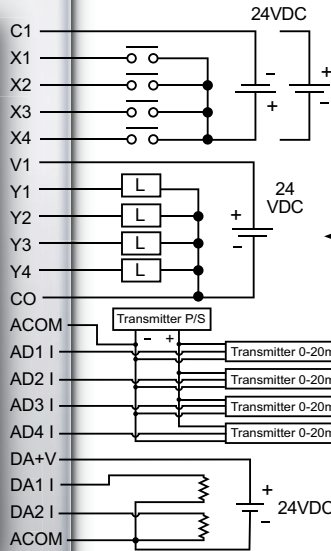

See Discrete I/O Specifications
Inputs (X1 - X4) High-Speed

See Discrete I/O Specifications
Outputs (Y1 - Y4)

See Analog I/O Specifications
Current
Input (AD1I - AD4I)

See Analog I/O Specifications
Current
Output (DA1I - DA2I)

| General Specifications | |
|-------------------------------------|----------------|
| Current Consumption at 24VDC | 140mA |
| Terminal Block Replacement Part No. | C0-16TB |
| Weight | 5.08 oz (144g) |



WARNING: When using an Ethernet Analog PLC unit, you must use CLICK programming software version V2.20 or later.

NOTE: Please refer to the Analog I/O Configuration section in Chapter 3 for information on using the analog I/O.



NOTE: There are no ZIPLink pre-wired PLC connection cables and modules for the Ethernet Analog PLCs (cannot mix discrete I/O and analog I/O signals in a ZIPLink cable).

C0-12DD2E-1-D (continued)

X1 - X4 (High-Speed)

| Discrete I/O Specifications - Inputs | |
|--------------------------------------|-------------------------------------|
| Inputs per Module | 4 (Sink/Source) |
| Operating Voltage Range | 24VDC |
| Input Voltage Range | 21.6-26.4 VDC |
| Input Current | Typ 6.5 mA @ 24VDC |
| Maximum Input Current | 7mA @ 26.4 VDC |
| Input Impedance | 3.9 kΩ @ 24VDC |
| Input Frequency (Max) | X1-X4: 100kHz |
| ON Voltage Level | >19VDC |
| OFF Voltage Level | < 2VDC |
| Minimum ON Current | 4.5 mA |
| Maximum OFF Current | 0.5 mA |
| OFF to ON Response | Typ 3μs Max 5μs |
| ON to OFF Response | Typ 1μs Max 3μs |
| Status Indicators | Logic Side (4 points, green LED) |
| Commons | 1 (4 points/common) |

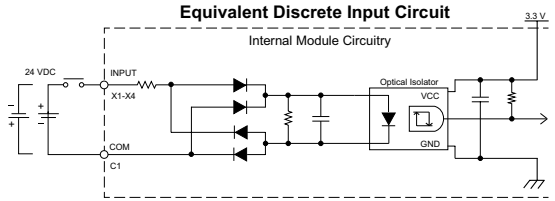

C0-12DD2E-1-D Temperature Derating Chart

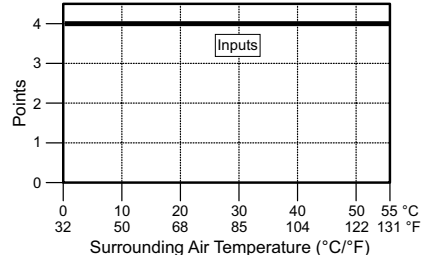

Y1 - Y4

| Discrete I/O Specifications - Outputs | |
|---------------------------------------|--------------------------------|
| Outputs per Module | 4 (Source) |
| Operating Voltage Range | 19.2-30 VDC |
| Maximum Output Current | 0.1 A/point; 0.4 A/common C0 |
| Minimum Output Current | 0.2 mA |
| Maximum Leakage Current | 0.1 mA @ 30.0 VDC |
| On Voltage Drop | 0.5 VDC @ 0.1 A |
| Maximum Inrush Current | 150mA for 10ms |
| OFF to ON Response | < 5μs |
| ON to OFF Response | < 5μs |
| Status Indicators | Logic side (4 points, red LED) |
| Commons | 1 (4 points/common) |

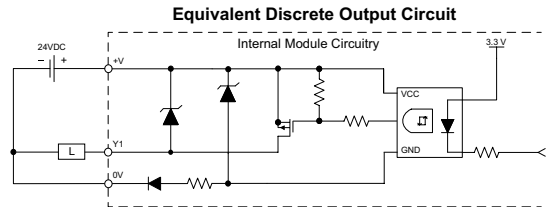

C0-12DD2E-1-D Temperature Derating Chart

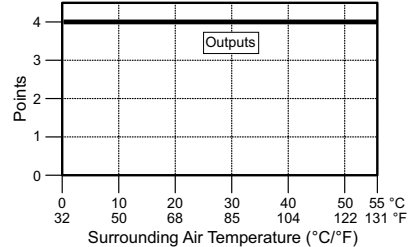

C0-12DD2E-1-D (continued)

AD1I - AD4I

| Analog Specifications - Current Input | |
|---------------------------------------|----------------------|
| Inputs per Module | 4 (current) |
| Input Range | 0–20 mA (sink) |
| Resolution | 12-bit |
| Conversion Time | 50ms |
| Input Impedance | 125Ω |
| Input Stability | ±2 LSB maximum |
| Full-Scale Calibration Error | ±2% maximum |
| Offset Calibration Error | ±0.1 mA maximum |
| Accuracy vs. Temperature Error | ±100ppm / °C maximum |

Analog Current Input Circuit

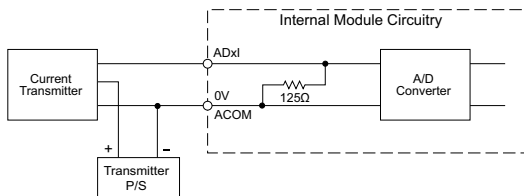

DA1I - DA2I

| Analog Specifications - Current Output | |
|--|---------------------------|
| Outputs per Module | 2 (current) |
| Output Range | 4–20 mA (source) |
| Resolution | 12-bit |
| Conversion Time | 2.5 ms |
| Load Impedance | 250Ω Typ (200Ω to 800Ω) |
| Loop Supply Voltage | 24VDC Typ (21.6–26.4 VDC) |
| Full-Scale Calibration Error | ±2% maximum |
| Offset Calibration Error | ±25mA maximum |
| Accuracy vs. Temperature Error | ±120ppm / °C maximum |
| External DC Power Required | 21.6–26.4 VDC |

Analog Current Output Circuit

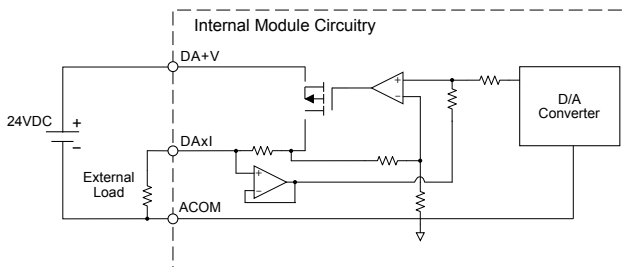

C0-12DRE-1-D – 4 DC Input (Sink/Source)/4 Relay Output;

4 Analog Current Input

2 Analog Current Output Micro PLC

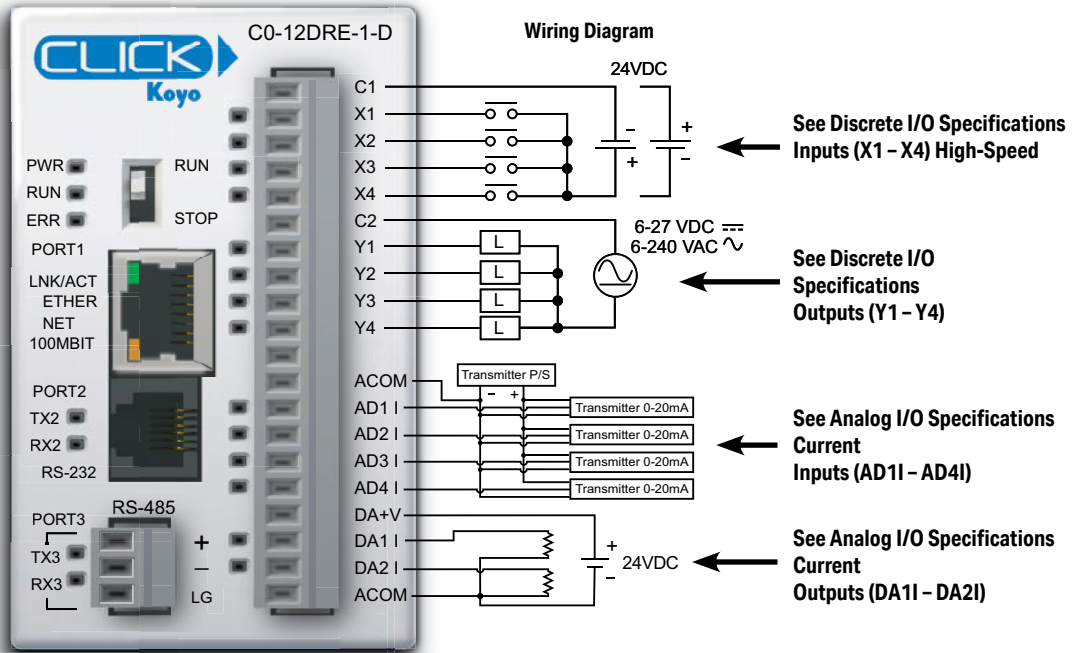

| General Specifications | |
|-------------------------------------|---------------|
| Current Consumption at 24VDC | 160mA |
| Terminal Block Replacement Part No. | C0-16TB |
| Weight | 5.3 oz (151g) |



WARNING: When using an Ethernet Analog PLC unit, you must use CLICK programming software version V2.20 or later.

NOTE: Please refer to the Analog I/O Configuration section in Chapter 3 for information on using the analog I/O.



NOTE: There are no ZIPLink pre-wired PLC connection cables and modules for the Ethernet Analog PLCs (cannot mix discrete I/O and analog I/O signals in a ZIPLink cable).

C0-12DRE-1-D (continued)

X1 - X4 (High-Speed)

| Discrete I/O Specifications - Inputs | |
|--------------------------------------|----------------------------------|
| Inputs per Module | 4 |
| Operating Voltage Range | 24VDC |
| Input Voltage Range | 21.6–26.4 VDC |
| Input Current | Typ 6.5 mA @ 24VDC |
| Max. Input Current | 7mA @ 26.4 VDC |
| Input Impedance | 3.9 kΩ @ 24VDC |
| Input Frequency (Max) | X1-X4: 100kHz |
| ON Voltage Level | >19VDC |
| OFF Voltage Level | < 2VDC |
| Minimum ON Current | 4.5 mA |
| Maximum OFF Current | 0.5 mA |
| OFF to ON Response | Typ 3μs Max 5μs |
| ON to OFF Response | Typ 1μs Max 3μs |
| Status Indicators | Logic Side (4 points, green LED) |
| Commons | 1 (4 points/common) |

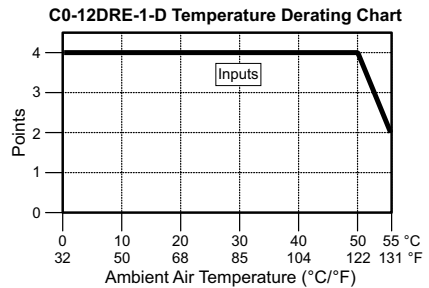
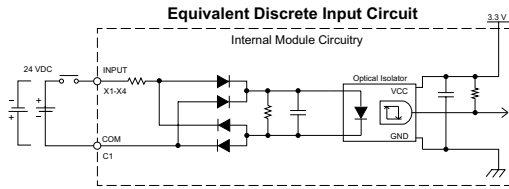

Y1 - Y4

| Discrete I/O Specifications - Outputs | |
|---------------------------------------|--------------------------------|
| Outputs per Module | 4 |
| Operating Voltage Range | 6–27 VDC, 6–240 VAC |
| Output Type | Relay, form A (SPST) |
| AC Frequency | 47–63 Hz |
| Maximum Current | 1A/point (resistive) |
| Minimum Load Current | 5mA @ 5VDC |
| Maximum Inrush Current | 3A for 10ms |
| OFF to ON Response | < 15ms |
| ON to OFF Response | < 15ms |
| Status Indicators | Logic Side (4 points, red LED) |
| Commons | 1 (4 points/common) |

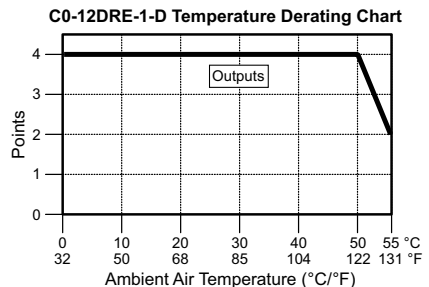
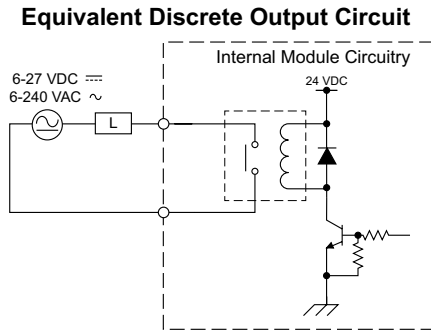

| Typical Relay Life (Operations) at Room Temperature | |
|---|----------------|
| Voltage & Load Type | Relay Life |
| 30VDC, 1A Resistive | 300,000 cycles |
| 30VDC, 1A Solenoid | 50,000 cycles |
| 120VAC, 1A Resistive | 500,000 cycles |
| 120VAC, 1A Solenoid | 200,000 cycles |
| ON to OFF = 1 cycle | |

C0-12DRE-1-D (continued)

AD1I - AD4I

| Analog Specifications - Current Input | |
|---------------------------------------|----------------------|
| Inputs per Module | 4 (Current) |
| Input Range | 0–20 mA (Sink) |
| Resolution | 12-bit |
| Conversion Time | 50ms |
| Input Impedance | 125Ω |
| Input Stability | ±2 LSB maximum |
| Full-Scale Calibration Error | ±2% maximum |
| Offset Calibration Error | ±0.1 mA maximum |
| Accuracy vs. Temperature Error | ±100ppm / °C maximum |

Analog Current Input Circuit

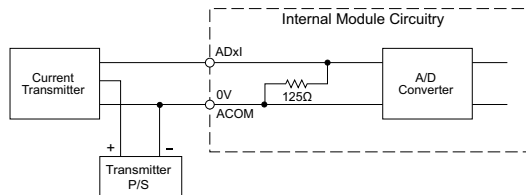

DA1I - DA2I

| Analog Specifications - Current Output | |
|--|-------------------------|
| Outputs per Module | 2 (Current) |
| Output Range | 4–20 mA (Source) |
| Resolution | 12-bit |
| Conversion Time | 2.5 ms |
| Load Impedance | 250Ω Typ (200Ω to 800Ω) |
| Loop Supply Voltage | 24VDC Typ (21.6–26.4) |
| Full-Scale Calibration Error | ±2% maximum |
| Offset Calibration Error | ±25mA maximum |
| Accuracy vs. Temperature Error | ±120ppm / °C maximum |
| External DC Power Required | 21.6–26.4 VDC |

Analog Current Output Circuit

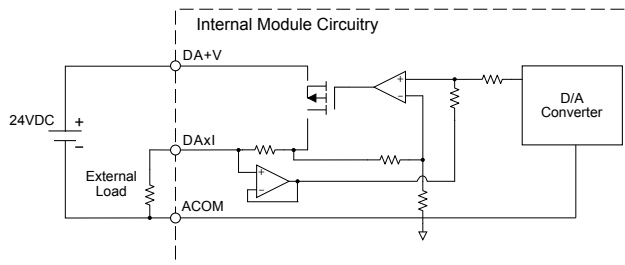

C0-12ARE-1-D – 4 AC Input/4 Relay Output;

4 Analog Current Input

2 Analog Current Output Micro PLC

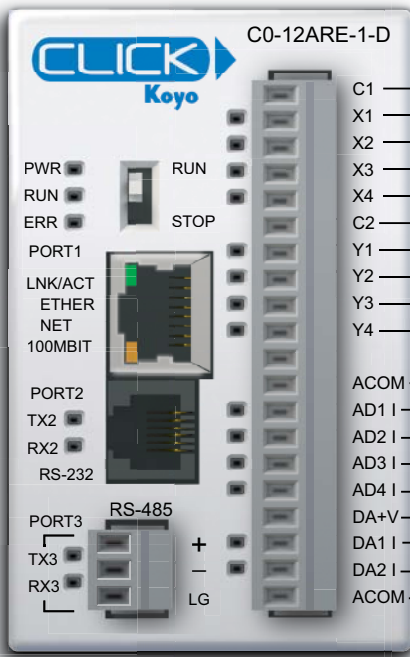

Wiring Diagram

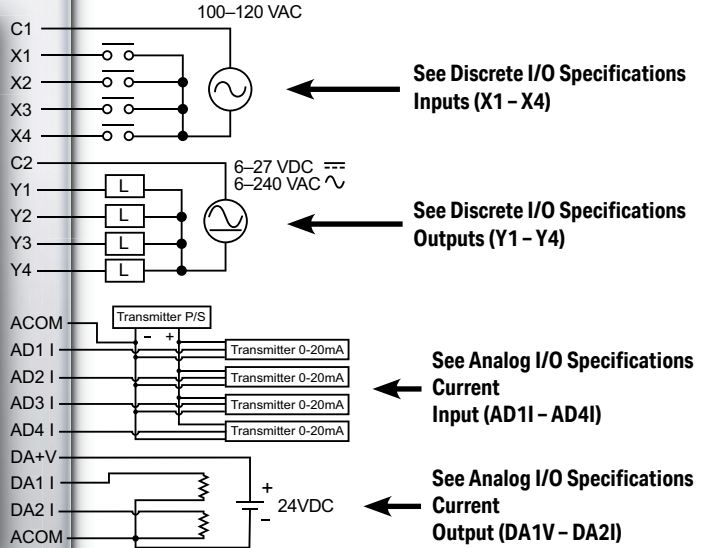

General Specifications

| | |
|-------------------------------------|---------------|
| Current Consumption at 24VDC | 160mA |
| Terminal Block Replacement Part No. | C0-16TB |
| Weight | 5.4 oz (154g) |



WARNING: When using an Ethernet Analog PLC unit, you must use CLICK programming software version V2.20 or later.



NOTE: Please refer to the Analog I/O Configuration section in Chapter 3 for information on using the analog I/O.

NOTE: There are no ZIPLink pre-wired PLC connection cables and modules for the Ethernet Analog PLCs (cannot mix discrete I/O and analog I/O signals in a ZIPLink cable).

C0-12ARE-1-D (continued)

X1 - X4

| Discrete I/O Specifications - Inputs | |
|--------------------------------------|--|
| Inputs per Module | 4 |
| Operating Voltage Range | 100-120 VAC |
| AC Frequency | 47-63 Hz |
| Input Current | Typ 8.5 mA @ 100VAC at 50Hz Typ 10mA @ 100VAC at 60Hz |
| Maximum Input Current | 16mA @ 144VAC |
| Input Impedance | 15kΩ @ 50Hz 12kΩ @ 60Hz |
| ON Voltage Level | > 60VAC |
| OFF Voltage Level | < 20VAC |
| Minimum ON Current | 5mA |
| Maximum OFF Current | 2mA |
| OFF to ON Response | < 40ms |
| ON to OFF Response | < 40ms |
| Status Indicators | Logic Side (4 points, green LED) |
| Commons | 1 (4 points/common) |

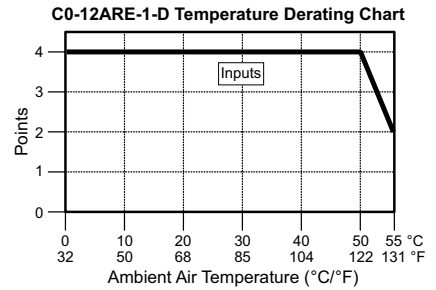
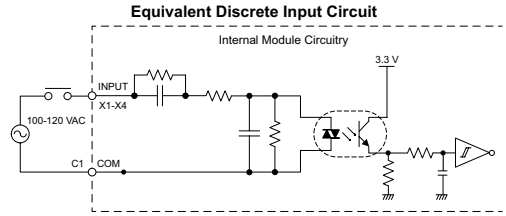

Y1 - Y4

| Discrete I/O Specifications - Outputs | |
|---------------------------------------|--------------------------------|
| Outputs per Module | 4 |
| Operating Voltage Range | 6-27 VDC, 6-240 VAC |
| Output Type | Relay, form A (SPST) |
| AC Frequency | 47-63 Hz |
| Maximum Current | 1A/point (resistive) |
| Minimum Load Current | 5mA @ 5VDC |
| Maximum Inrush Current | 3A for 10ms |
| OFF to ON Response | < 15ms |
| ON to OFF Response | < 15ms |
| Status Indicators | Logic Side (4 points, red LED) |
| Commons per Module | 1 (4 points/common) |

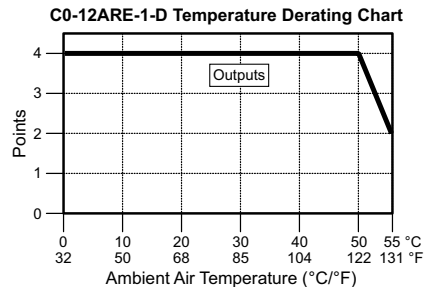
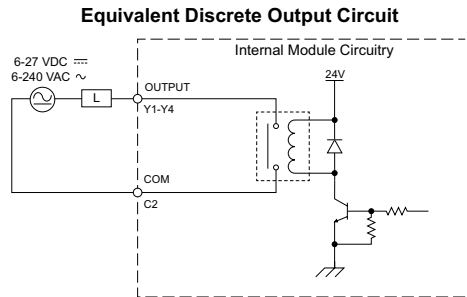

| Typical Relay Life (Operations) at Room Temperature | |
|---|----------------|
| Voltage & Load Type | Relay Life |
| 30VDC, 1A Resistive | 300,000 cycles |
| 30VDC, 1A Solenoid | 50,000 cycles |
| 120VAC, 1A Resistive | 500,000 cycles |
| 120VAC, 1A Solenoid | 200,000 cycles |

ON to OFF = 1 cycle

C0-12ARE-1-D (continued)

AD1I – AD4I

| Analog Specifications - Current Input | |
|---------------------------------------|----------------------|
| Inputs per Module | 4 (current) |
| Input Range | 0–20 mA (sink) |
| Resolution | 12-bit |
| Conversion Time | 50ms |
| Input Impedance | 125Ω |
| Input Stability | ±2 LSB maximum |
| Full-Scale Calibration Error | ±2% maximum |
| Offset Calibration Error | ±0.1 mA maximum |
| Accuracy vs. Temperature Error | ±100ppm / °C maximum |

Analog Current Input Circuit

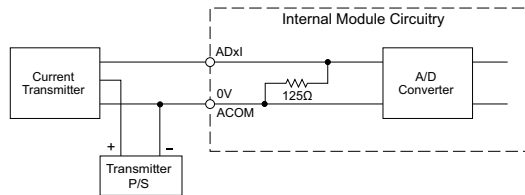

DA1I – DA2I

| Analog Specifications - Current Output | |
|--|--------------------------|
| Outputs per Module | 2 (current) |
| Output Range | 4–20 mA (source) |
| Resolution | 12-bit |
| Conversion Time | 2.5 ms |
| Load Impedance | 250Ω Typ (200Ω to 800Ω) |
| Loop Supply Voltage | DC 24V Typ (21.6–26.4 V) |
| Full-Scale Calibration Error | ±2% maximum |
| Offset Calibration Error | ±25mA maximum |
| Accuracy vs. Temperature Error | ±120ppm / °C maximum |
| External DC Power Supply Required | 21.6–26.4 VDC |

Analog Current Output Circuit

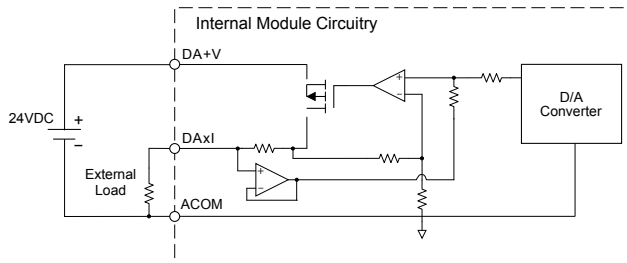

**C0-12DD1E-2-D – 4 DC Input (Sink/Source)/4 Sinking DC Output;
4 Analog Voltage Input
2 Analog Voltage Output Micro PLC**

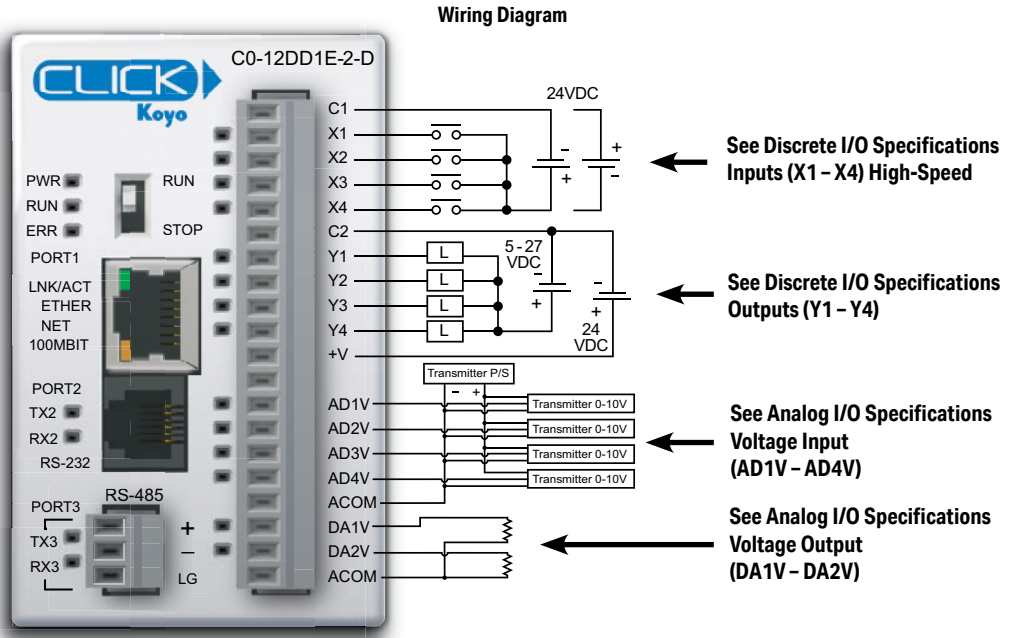

| General Specifications | |
|-------------------------------------|----------------|
| Current Consumption at 24VDC | 140mA |
| Terminal Block Replacement Part No. | C0-16TB |
| Weight | 5.08 oz (144g) |



WARNING: When using an Ethernet Analog PLC unit, you must use CLICK programming software version V2.20 or later.

NOTE: Please refer to the Analog I/O Configuration section in Chapter 3 for information on using the analog I/O.



NOTE: There are no ZIPLink pre-wired PLC connection cables and modules for the Ethernet Analog PLCs (cannot mix discrete I/O and analog I/O signals in a ZIPLink cable).

C0-12DD1E-2-D (continued)

X1 - X4 (High-Speed)

| Discrete I/O Specifications - Inputs | |
|--------------------------------------|----------------------------------|
| Inputs per Module | 4 (Source/Sink) |
| Operating Voltage Range | 24VDC |
| Input Voltage Range | 21.6–26.4 VDC |
| Input Current | Typ 6.5 mA @ 24VDC |
| Max. Input Current | 7mA @ 26.4 VDC |
| Input Impedance | 3.9 kΩ @ 24VDC |
| ON Voltage Level | >19VDC |
| OFF Voltage Level | < 2VDC |
| Minimum ON Current | 4.5 mA |
| Maximum OFF Current | 0.5 mA |
| OFF to ON Response | Typ 3μs Max 5μs |
| ON to OFF Response | Typ 1μs Max 3μs |
| Status Indicators | Logic Side (4 points, green LED) |
| Commons | 1 (4 points/common) |

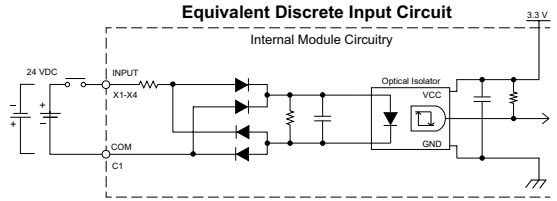

C0-12DD1E-2-D Temperature Derating Chart

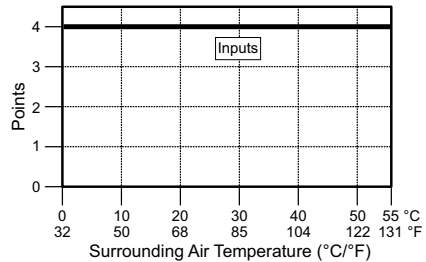

Y1 - Y4

| Discrete I/O Specifications - Outputs | |
|---------------------------------------|--|
| Outputs per Module | 4 (Sink) |
| Operating Voltage Range | 5–27 VDC |
| Maximum Output Current | 0.1 A/point; 0.4 A/common |
| Minimum Output Current | 0.2 mA |
| Maximum Leakage Current | 0.1 mA @ 30.0 VDC |
| On Voltage Drop | 0.5 VDC @ 0.1 A |
| Maximum Inrush Current | 150 mA for 10ms |
| OFF to ON Response | 5μs |
| ON to OFF Response | 5μs |
| Status Indicators | Logic Side (4 points, red LED) |
| Commons | 1 (4 points/common) |
| External DC Power Required | 20–28 VDC Maximum @ 60mA (All points on) |

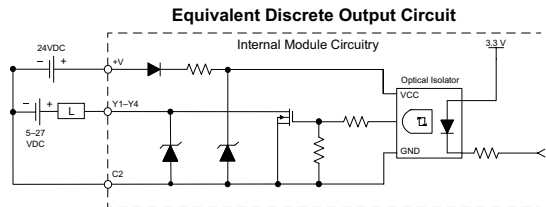

C0-12DD1E-2-D Temperature Derating Chart

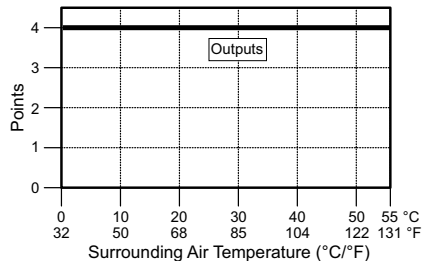

C0-12DD1E-2-D (continued)

AD1V - AD4V

| Analog Specifications - Voltage Input | |
|---------------------------------------|--------------------------------------|
| Inputs per Module | 4 (voltage) |
| Input Range | 0-10 VDC |
| Resolution | 12-bit |
| Conversion Time | 50ms |
| Input Impedance | 40k Ω |
| Input Stability | ± 2 LSB maximum |
| Full-Scale Calibration Error | $\pm 2\%$ maximum |
| Offset Calibration Error | ± 25 mV maximum |
| Accuracy vs. Temperature Error | ± 100 ppm / $^{\circ}$ C maximum |

Analog Voltage Input Circuit

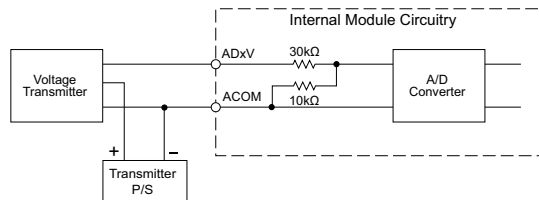

DA1V - DA2V

| Analog Specifications - Voltage Output | |
|--|--|
| Outputs per Module | 2 (voltage) |
| Output Range | 0-10 VDC |
| Resolution | 12-bit |
| Conversion Time | 1ms |
| Load Impedance | 4k Ω minimum (output current 2.5 mA maximum) |
| Full-Scale Calibration Error | $\pm 2\%$ maximum |
| Offset Calibration Error | ± 25 mV maximum |
| Accuracy vs. Temperature Error | ± 100 ppm / $^{\circ}$ C maximum |

Analog Voltage Output Circuit

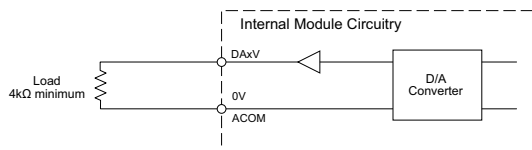

**C0-12DD2E-2-D – 4 DC Input (Sink/Source)/4 Sourcing DC Output;
4 Analog Voltage Input
2 Analog Voltage Output Micro PLC**

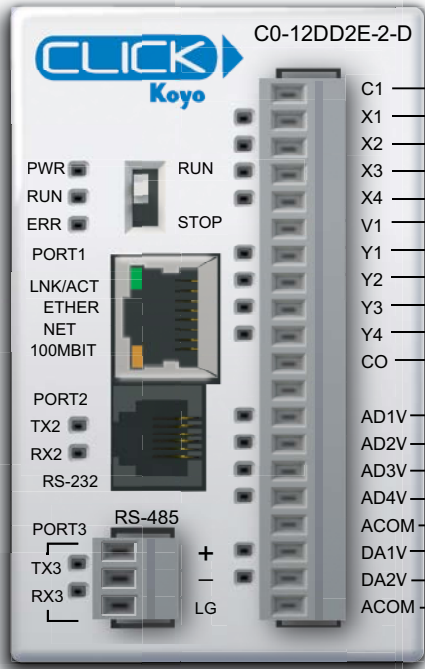

Wiring Diagram

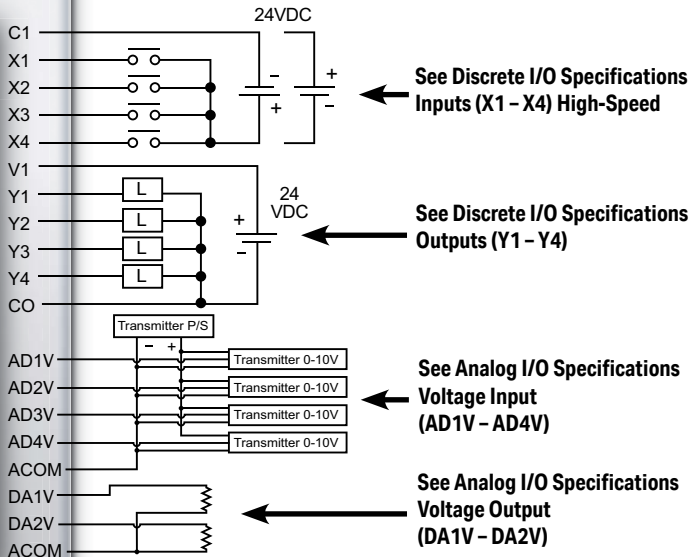

| General Specifications | |
|-------------------------------------|----------------|
| Current Consumption at 24VDC | 140mA |
| Terminal Block Replacement Part No. | C0-16TB |
| Weight | 5.08 oz (144g) |



WARNING: When using an Ethernet Analog PLC unit, you must use CLICK programming software version V2.20 or later.



NOTE: Please refer to the Analog I/O Configuration section in Chapter 3 for information on using the analog I/O.

NOTE: There are no ZIPLink pre-wired PLC connection cables and modules for the Ethernet Analog PLCs (cannot mix discrete I/O and analog I/O signals in a ZIPLink cable).

C0-12DD2E-2-D (continued)

X1 - X4 (High-Speed)

| Discrete I/O Specifications - Inputs | |
|--------------------------------------|----------------------------------|
| Inputs per Module | 4 (Source/Sink) |
| Operating Voltage Range | 24VDC |
| Input Voltage Range | 21.6–26.4 VDC |
| Input Current | Typ 6.5 mA @ 24VDC |
| Max. Input Current | 7mA @ 26.4 VDC |
| Input Impedance | 3.9 kΩ @ 24VDC |
| ON Voltage Level | >19VDC |
| OFF Voltage Level | < 2VDC |
| Minimum ON Current | 4.5 mA |
| Maximum OFF Current | 0.5 mA |
| OFF to ON Response | Typ 3μs Max 5μs |
| ON to OFF Response | Typ 1μs Max 3μs |
| Status Indicators | Logic Side (4 points, green LED) |
| Commons | 1 (4 points/common) |

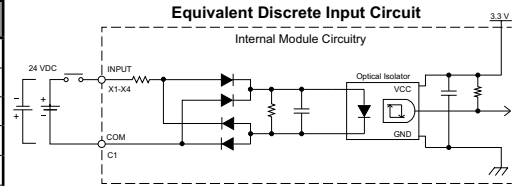

C0-12DD2E-2-D Temperature Derating Chart

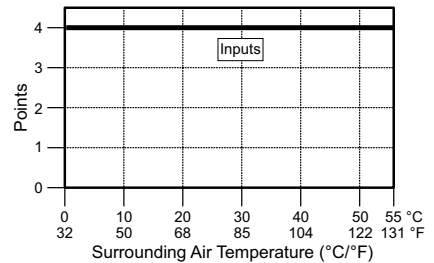

Y1 - Y4

| Discrete I/O Specifications - Outputs | |
|---------------------------------------|--------------------------------|
| Outputs per Module | 4 (Source) |
| Operating Voltage Range | 24VDC |
| Output Voltage Range | 19.2–30 VDC |
| Maximum Output Current | 0.1 A/point, 0.4 A/common |
| Minimum Output Current | 0.2 mA |
| Maximum Leakage Current | 0.1mA @ 30VDC |
| On Voltage Drop | 0.5 VDC@ 0.1 mA |
| Maximum Inrush Current | 150mA for 10ms |
| OFF to ON Response | < 5μs |
| ON to OFF Response | < 5μs |
| Status Indicators | Logic Side (4 points, red LED) |
| Commons | 1 (4 points/common) |

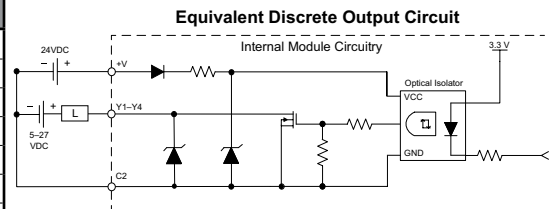

C0-12DD2E-2-D Temperature Derating Chart

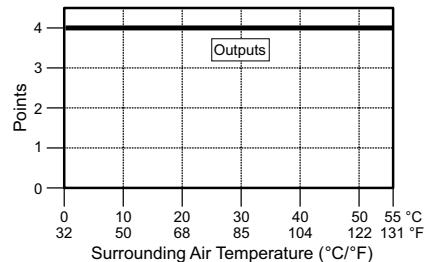

C0-12DD2E-2-D (continued)

AD1V - AD4V

| Analog Specifications - Voltage Input | |
|---------------------------------------|----------------------|
| Inputs per Module | 4 (voltage) |
| Input Range | 0-10 VDC |
| Resolution | 12-bit |
| Conversion Time | 50ms |
| Input Impedance | 40kΩ |
| Input Stability | ±2 LSB maximum |
| Full-Scale Calibration Error | ±2% maximum |
| Offset Calibration Error | ±25mV maximum |
| Accuracy vs. Temperature Error | ±100ppm / °C maximum |

Analog Voltage Input Circuit

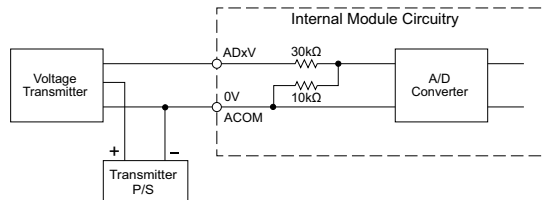

DA1V - DA2V

| Analog Specifications - Voltage Output | |
|--|--|
| Outputs per Module | 2 (voltage) |
| Output Range | 0-10 VDC |
| Resolution | 12-bit |
| Conversion Time | 1ms |
| Load Impedance | 4kΩ minimum (output current 2.5 mA maximum) |
| Full-Scale Calibration Error | ±2% maximum |
| Offset Calibration Error | ±25mV maximum |
| Accuracy vs. Temperature Error | ±100ppm / °C maximum |

Analog Voltage Output Circuit

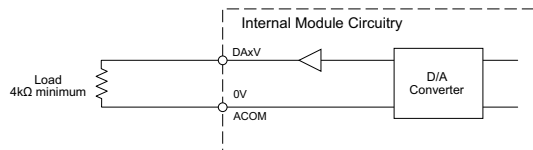

C0-12DRE-2-D – 4 DC Input (Sink/Source)/4 Relay Output;

4 Analog Voltage Input

2 Analog Voltage Output Micro PLC

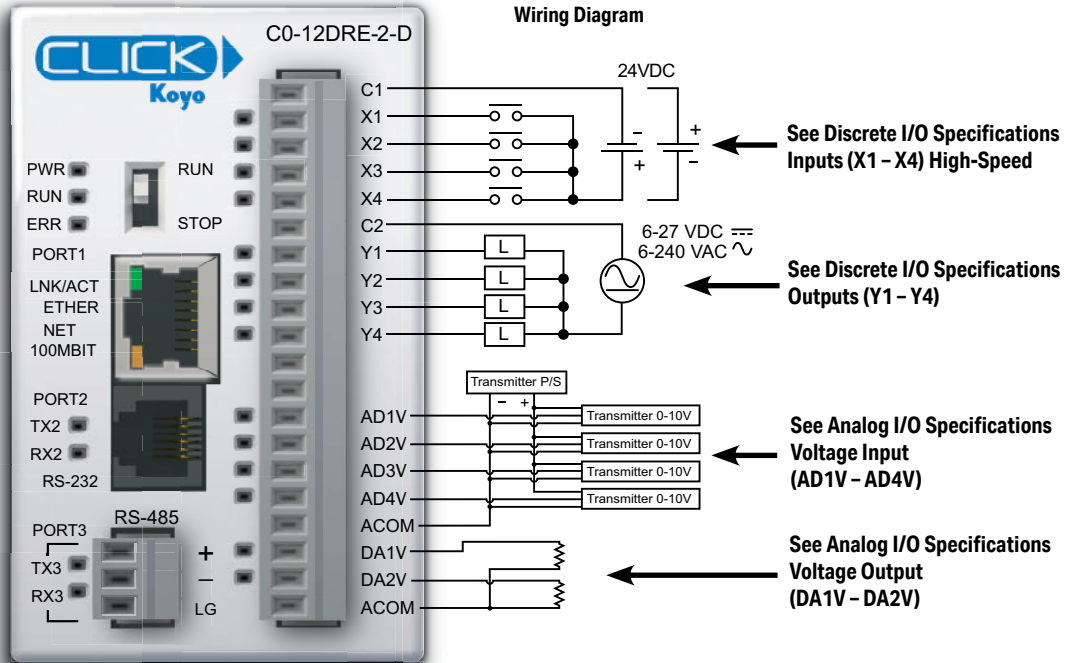

| General Specifications | |
|-------------------------------------|---------------|
| Current Consumption at 24VDC | 160mA |
| Terminal Block Replacement Part No. | C0-16TB |
| Weight | 5.4 oz (154g) |



WARNING: When using an Ethernet Analog PLC unit, you must use CLICK programming software version V2.20 or later.

NOTE: Please refer to the Analog I/O Configuration section in Chapter 3 for information on using the analog I/O.



NOTE: There are no ZIPLink pre-wired PLC connection cables and modules for the Ethernet Analog PLCs (cannot mix discrete I/O and analog I/O signals in a ZIPLink cable).

C0-12DRE-2-D (continued)

X1 - X4 (High-Speed)

| Discrete I/O Specifications - Inputs | |
|--------------------------------------|----------------------------------|
| Inputs per Module | 4 |
| Operating Voltage Range | 24VDC |
| Input Voltage Range | 21.6–26.4 VDC |
| Input Current | Typ 6.5 mA @ 24VDC |
| Max. Input Current | 7mA @ 26.4 VDC |
| Input Impedance | 3.9 kΩ @ 24VDC |
| ON Voltage Level | >19VDC |
| OFF Voltage Level | < 2VDC |
| Minimum ON Current | 4.5 mA |
| Maximum OFF Current | 0.5 mA |
| OFF to ON Response | Typ 3μs Max 5μs |
| ON to OFF Response | Typ 1μs Max 3μs |
| Status Indicators | Logic side (4 points, green LED) |
| Commons | 1 (4 points/common) |

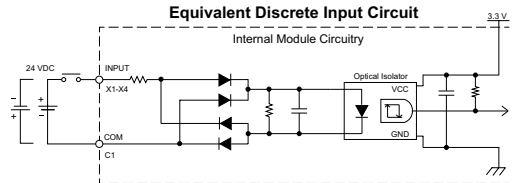

C0-12DRE-2-D Temperature Derating Chart

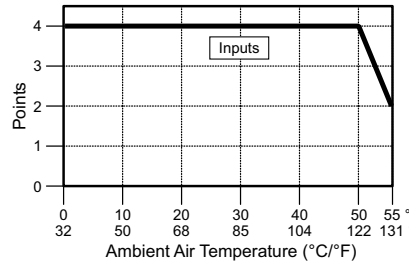

Y1 - Y4

| Discrete I/O Specifications - Outputs | |
|---------------------------------------|--------------------------------|
| Outputs per Module | 4 |
| Operating Voltage Range | 6–27 VDC, 6–240 VAC |
| Output Type | Relay, form A (SPST) |
| AC Frequency | 47–63 Hz |
| Maximum Current | 1A/point (resistive) |
| Minimum Load Current | 5mA @ 5VDC |
| Maximum Inrush Current | 3A for 10ms |
| OFF to ON Response | < 15ms |
| ON to OFF Response | < 15ms |
| Status Indicators | Logic Side (4 points, red LED) |
| Commons per Module | 1 (4 points/common) |

Equivalent Discrete Output Circuit

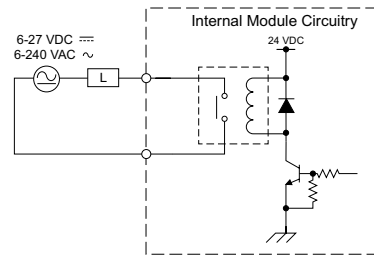

C0-12DRE-2-D Temperature Derating Chart

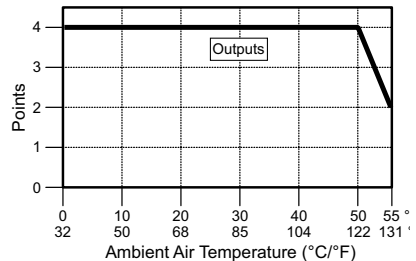

Typical Relay Life (Operations) at Room Temperature

| Voltage & Load Type | Relay Life |
|----------------------|----------------|
| 30VDC, 1A Resistive | 300,000 cycles |
| 30VDC, 1A Solenoid | 50,000 cycles |
| 120VAC, 1A Resistive | 500,000 cycles |
| 120VAC, 1A Solenoid | 200,000 cycles |

ON to OFF = 1 cycle

C0-12DRE-2-D (continued)

AD1V - AD4V

| Analog Specifications - Voltage Input | |
|---------------------------------------|----------------------|
| Inputs per Module | 4 (voltage) |
| Input Range | 0–10 VDC |
| Resolution | 12-bit |
| Conversion Time | 50ms |
| Input Impedance | 40kΩ |
| Input Stability | ±2 LSB maximum |
| Full-Scale Calibration Error | ±2% maximum |
| Offset Calibration Error | ±25mV maximum |
| Accuracy vs. Temperature Error | ±100ppm / °C maximum |

Analog Voltage Input Circuit

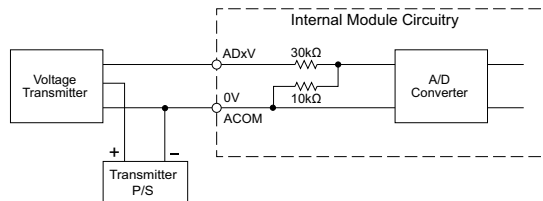

DA1V - DA2V

| Analog Specifications - Voltage Output | |
|--|---|
| Outputs per Module | 2 (voltage) |
| Output Range | 0–10 VDC |
| Resolution | 12-bit |
| Conversion Time | 1ms |
| Load Impedance | 4kΩ minimum (output current 2.5 mA maximum) |
| Full-Scale Calibration Error | ±2% maximum |
| Offset Calibration Error | ±25mV maximum |
| Accuracy vs. Temperature Error | ±100ppm / °C maximum |

Analog Voltage Output Circuit

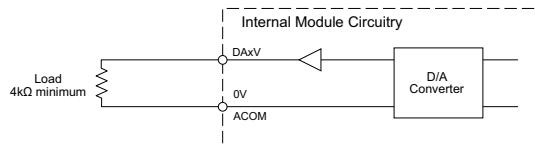

**C0-12ARE-2-D – 4 AC Input (Sink/Source) /4 Relay Output;
4 Analog Voltage Input
2 Analog Voltage Output Micro PLC**

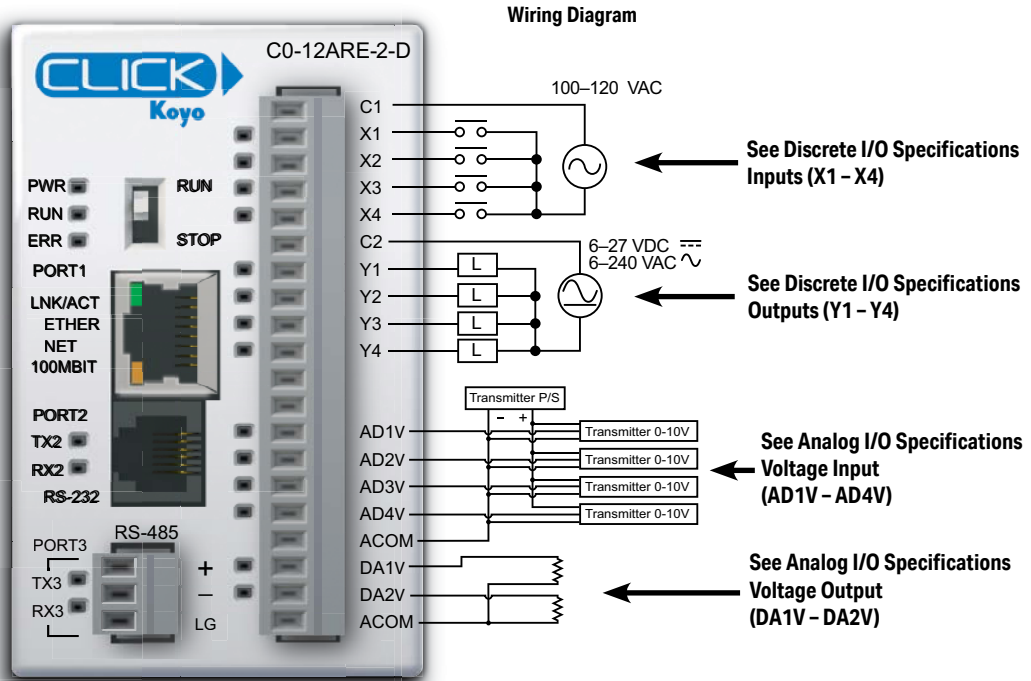

| General Specifications | |
|--|---------------|
| Current Consumption at 24VDC | 140mA |
| Terminal Block Replacement Part No. | C0-16TB |
| Weight | 5.4 oz (155g) |



WARNING: When using an Ethernet Analog PLC unit, you must use CLICK programming software version V2.20 or later.

NOTE: Please refer to the Analog I/O Configuration section in Chapter 3 for information on using the analog I/O.



NOTE: There are no ZIPLink pre-wired PLC connection cables and modules for the Ethernet Analog PLCs (cannot mix discrete I/O and analog I/O signals in a ZIPLink cable).

C0-12ARE-2-D (continued)

X1 - X4

| Discrete I/O Specifications - Inputs | |
|--------------------------------------|--|
| Inputs per Module | 4 |
| Operating Voltage Range | 100-120 VAC |
| AC Frequency | 47-63 Hz |
| Input Current | Typ 8.5 mA @ 100VAC at 50Hz Typ 10mA @ 100VAC at 60Hz |
| Maximum Input Current | 16mA @ 144VAC |
| Input Impedance | 15kΩ @ 50Hz 12kΩ @ 60Hz |
| ON Voltage Level | > 60VAC |
| OFF Voltage Level | < 20VAC |
| Minimum ON Current | 5mA |
| Maximum OFF Current | 2mA |
| OFF to ON Response | < 40ms |
| ON to OFF Response | < 40ms |
| Status Indicators | Logic Side (4 points, green LED) |
| Commons | 1 (4 points/common) |

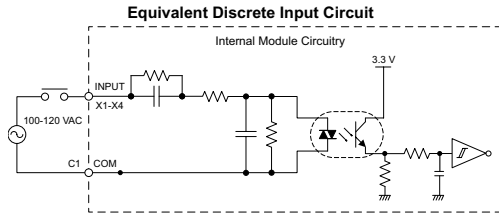

C0-12ARE-2-D Temperature Derating Chart

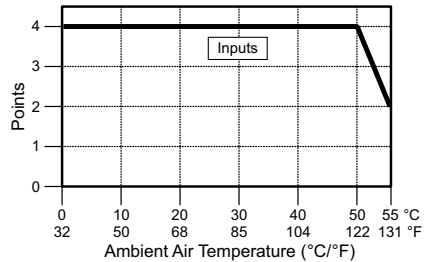

Y1 - Y4

| Discrete I/O Specifications - Outputs | |
|---------------------------------------|--------------------------------|
| Outputs per Module | 4 |
| Operating Voltage Range | 6-27 VDC, 6-240 VAC |
| Output Type | Relay, form A (SPST) |
| AC Frequency | 47-63 Hz |
| Maximum Current | 1A/point (resistive) |
| Minimum Load Current | 5mA @ 5VDC |
| Maximum Inrush Current | 3A for 10ms |
| OFF to ON Response | < 15ms |
| ON to OFF Response | < 15ms |
| Status Indicators | Logic Side (4 points, red LED) |
| Commons per Module | 1 (4 points/common) |

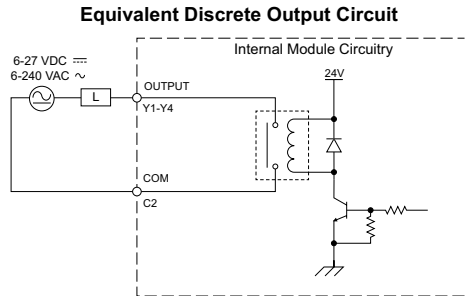

C0-12ARE-2-D Temperature Derating Chart

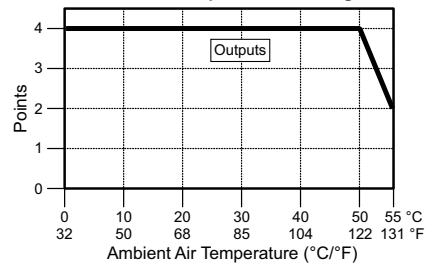

| Typical Relay Life (Operations) at Room Temperature | |
|---|----------------|
| Voltage & Load Type | Relay Life |
| 30VDC, 1A Resistive | 300,000 cycles |
| 30VDC, 1A Solenoid | 50,000 cycles |
| 120VAC, 1A Resistive | 500,000 cycles |
| 120VAC, 1A Solenoid | 200,000 cycles |

ON to OFF = 1 cycle

C0-12ARE-2-D (continued)

AD1V - AD4V

| Analog Specifications - Voltage Input | |
|---------------------------------------|----------------------|
| Inputs per Module | 4 (voltage) |
| Input Range | 0-10 VDC |
| Resolution | 12-bit |
| Conversion Time | 50ms |
| Input Impedance | 40kΩ |
| Input Stability | ±2 LSB maximum |
| Full-Scale Calibration Error | ±2% maximum |
| Offset Calibration Error | ±25mV maximum |
| Accuracy vs. Temperature Error | ±100ppm / °C maximum |

Analog Voltage Input Circuit

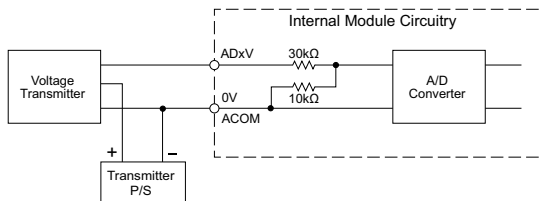

DA1V - DA2V

| Analog Specifications - Voltage Output | |
|--|---|
| Outputs per Module | 2 (voltage) |
| Output Range | 0-10 VDC |
| Resolution | 12-bit |
| Conversion Time | 1ms |
| Load Impedance | 4kΩ minimum (output current 2.5 mA maximum) |
| Full-Scale Calibration Error | ±2% maximum |
| Offset Calibration Error | ±25mV maximum |
| Accuracy vs. Temperature Error | ±100ppm / °C maximum |

Analog Voltage Output Circuit

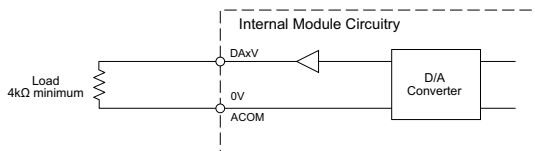

I/O Module Specifications

I/O Terminal Block Specifications for CPUs and I/O Modules



11-Pin Terminal Block,
CO-8TB

| 11-pin Terminal Block Specifications | |
|--------------------------------------|--------------------------|
| Connector Type | Pluggable Terminal Block |
| Number of Pins | 11 pt |
| Pitch | 3.50 mm |
| Wire Range | 28–16 AWG |
| Wire Strip Length | 7mm |
| Screw Size | M2.0 |
| Screw Torque | 2.0 to 2.2 lb-inch |
| AutomationDirect Part Number | CO-8TB |

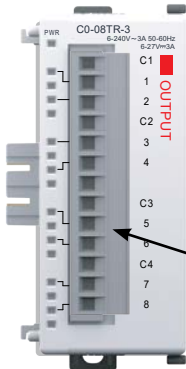

13-Pin Terminal Block,
CO-8TB-1

| 13-pin Terminal Block Specifications | |
|--------------------------------------|--------------------------|
| Connector Type | Pluggable Terminal Block |
| Number of Pins | 13 pt |
| Pitch | 5.08 mm |
| Wire Range | 12–20 AWG |
| Wire Strip Length | 7.0–8.0 mm |
| Screw Size | M2.5 |
| Screw Torque | 4.51 lb-inch |
| AutomationDirect Part Number | CO-8TB-1 |



20-Pin Terminal Block,
CO-16TB

| 20-pin Terminal Block Specifications | |
|--------------------------------------|--------------------------|
| Connector Type | Pluggable Terminal Block |
| Number of Pins | 20 pt |
| Pitch | 3.50 mm |
| Wire Range | 28–16 AWG |
| Wire Strip Length | 7mm |
| Screw Size | M2.0 |
| Screw Torque | 2.0 to 2.2 lb-inch |
| AutomationDirect Part Number | CO-16TB |

LED Indicators

All CLICK I/O modules, except analog modules, have an LED Power Indicator (PWR). When this LED is on, the I/O module is receiving 24VDC through the backplane connector correctly. The input modules have green LEDs and the output modules have red LEDs respectively as the status indicator. When the LED is on, the I/O point is on.

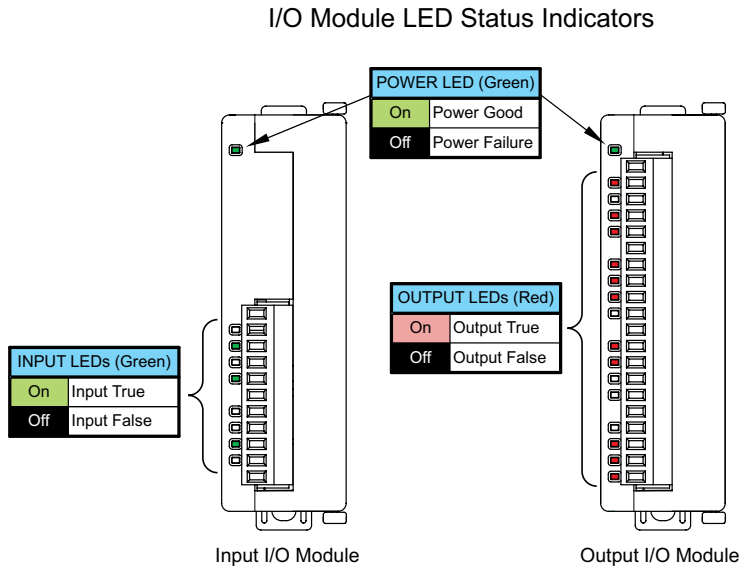

C0-08SIM – 8-Point Toggle Switch Input Module

8-point toggle switch input module provides for simple simulation of system discrete inputs.



| Input Specifications | |
|---------------------------|---|
| Inputs per Module | 8 Toggle Switches |
| OFF to ON Response | Max 140ms, Typ 90ms |
| ON to OFF Response | Max 110ms, Typ 60ms |
| Status Indicators | Logic Side (8 points, green LED) Power Indicator (green LED) |
| Bus Power Required | Max. 50mA (All points ON) |
| Weight | 2.9 oz (84g) |



CAUTION

The C0-08SIM unit toggle switch can get hot when mounted in hot environment. Wear heat-resistant gloves before use, as it may cause burns.

C0-08ND3 – 8-Point Sink/Source DC Input Module

8-point 12–24 VDC current sinking or sourcing input module, 2 commons, isolated, removable terminal block included.

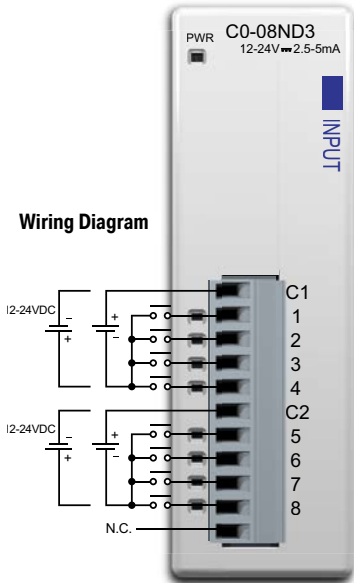

N.C. = Not Connected

| Input Specifications | |
|----------------------------|---|
| Inputs per Module | 8 (Sink/Source) |
| Operating Voltage Range | 12–24 VDC |
| Input Voltage Range | 10.8–26.4 VDC |
| Input Current | Typ 5mA @ 24VDC |
| Maximum Input Current | 7mA @ 26.4 VDC |
| Input Impedance | 4.7 kΩ @ 24VDC |
| ON Voltage Level | > 8.0 VDC |
| OFF Voltage Level | < 3.0 VDC |
| Minimum ON Current | 1.4 mA |
| Maximum OFF Current | 0.5 mA |
| OFF to ON Response | Max 3.5 ms, Typ 2ms |
| ON to OFF Response | Max 4 ms, Typ 2.5 ms |
| Status Indicators | Logic Side (8 points, green LED) Power Indicator (green LED) |
| Commons | 2 (4 points/common) Isolated |
| Bus Power Required (24VDC) | Max. 30mA (All Inputs On) |
| Terminal Block Replacement | AutomationDirect p/n C0-8TB |
| Weight | 2.8 oz (80g) |

Equivalent Input Circuit

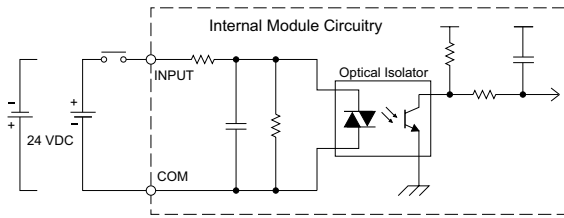

Input Module Temperature Derating Chart

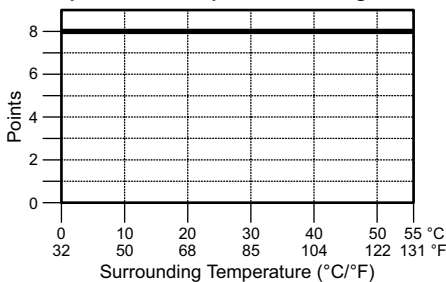

ZIPLink Pre-Wired PLC Connection Cables and Modules for CLICK PLC

- 11-pin connector cable
- ZL-C0-CBL11 (0.5 m length)
- ZL-C0-CBL11-1 (1.0 m length)
- ZL-C0-CBL11-2 (2.0 m length)



- ZL-RTB20
- 20-pin feed-through connector module



C0-08ND3-1 – 8-Point Sink/Source DC Input Module

8-point 3.3–5 VDC current sinking or sourcing input module, 2 commons, isolated, removable terminal block included.

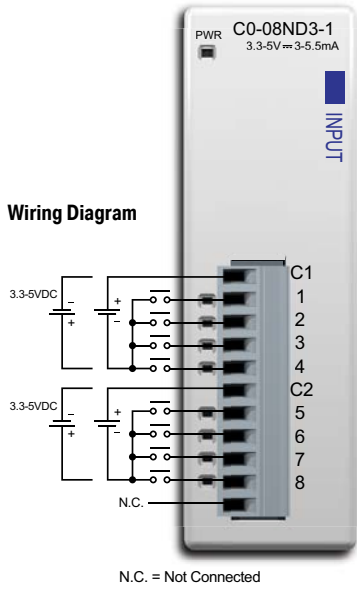

| Input Specifications | |
|-----------------------------------|---|
| Inputs per Module | 8 (Sink/Source) |
| Operating Voltage Range | 3.3–5 VDC |
| Input Voltage Range | 2.8–5.5 VDC |
| Input Current | Typ 5.5 mA @ 5 VDC |
| Maximum Input Current | 7.5 mA @ 5.5 VDC |
| Input Impedance | 680 Ω |
| ON Voltage Level | > 2.2 VDC |
| OFF Voltage Level | < 0.8 VDC |
| Minimum ON Current | 1.4 mA |
| Maximum OFF Current | 0.2 mA |
| OFF to ON Response | Max. 3ms Typ. 1.6 ms |
| ON to OFF Response | Max. 4ms Typ. 2.3 ms |
| Status Indicators | Logic Side (8 points, green LED) Power Indicator (green LED) |
| Commons | 2 (4 points/common) Isolated |
| Bus Power Required (24VDC) | Max. 30mA (All Inputs On) |
| Terminal Block Replacement | AutomationDirect p/n CO-8TB |
| Weight | 2.8 oz (80g) |

Equivalent Input Circuit

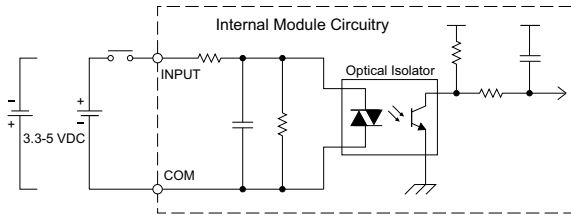

ZIPLink Pre-Wired PLC Connection Cables and Modules for CLICK PLC



- 11-pin connector cable
- ZL-C0-CBL11 (0.5 m length)
- ZL-C0-CBL11-1 (1.0 m length)
- ZL-C0-CBL11-2 (2.0 m length)

Input Module Temperature Derating Chart

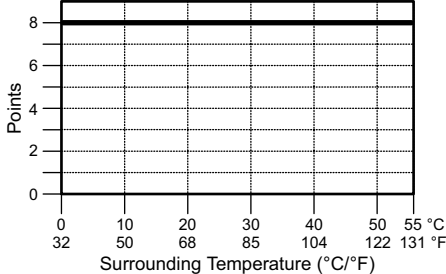

ZL-RTB20 20-pin feed-through connector module



C0-16ND3 – 16-Point Sink/Source DC Input Module

16-point 24VDC current sinking or sourcing input module, 4 commons, isolated, removable terminal block included.

Wiring Diagram

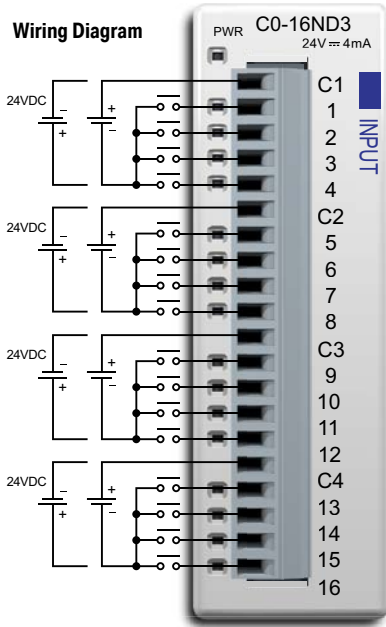

| Input Specifications | |
|----------------------------|--|
| Inputs per Module | 16 (Sink/Source) |
| Operating Voltage Range | 24VDC |
| Input Voltage Range | 21.6–26.4 VDC |
| Input Current | Typ 4.0 mA @ 24VDC |
| Maximum Input Current | 5.0 mA @ 26.4 VDC |
| Input Impedance | 6.8 kΩ @ 24VDC |
| ON Voltage Level | > 19VDC |
| OFF Voltage Level | < 7VDC |
| Minimum ON Current | 3.5 mA |
| Maximum OFF Current | 0.5 mA |
| OFF to ON Response | Max. 10ms Typ 2ms |
| ON to OFF Response | Max. 10ms Typ 3ms |
| Status Indicators | Logic Side (16 points, green LED) Power Indicator (green LED) |
| Commons | 4 (4 points/common) Isolated |
| Bus Power Required (24VDC) | Max. 40 mA (All Inputs On) |
| Terminal Block Replacement | AutomationDirect p/n C0-16TB |
| Weight | 3.2 oz (90g) |

Equivalent Input Circuit

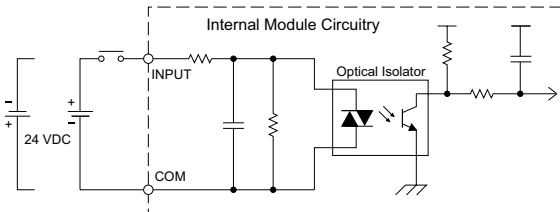

Z/PLink Pre-Wired PLC Connection Cables and Modules for CLICK PLC

- 20-pin connector cable
- ZL-C0-CBL20 (0.5 m length)
- ZL-C0-CBL20-1 (1.0 m length)
- ZL-C0-CBL20-2 (2.0 m length)



Input Module Temperature Derating Chart

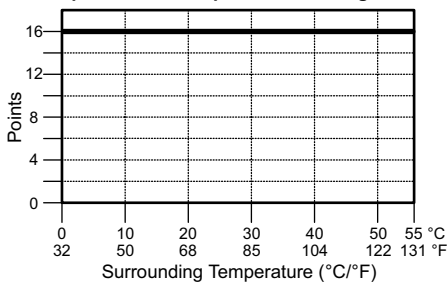

ZL-RTB20 20-pin feed-through connector module



ZL-LTB16-24-1 sensor input module

C0-08NE3 – 8-Point Sink/Source AC/DC Input Module

8-point 24VAC / 24VDC current sinking or sourcing input module, 2 commons, 4 points per common, removable terminal block included.

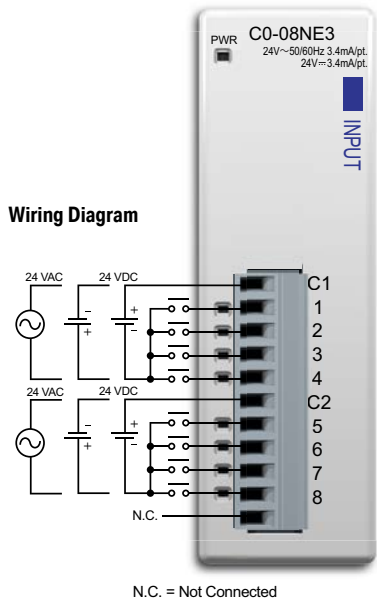

| Input Specifications | |
|-----------------------------------|---|
| Inputs per Module | 8 (Sink/Source) |
| Operating Voltage Range | 24 VAC/VDC |
| Input Voltage Range | 20.4–27.6 VAC/VDC |
| Peak Voltage | 27.6 VAC/VDC |
| AC Frequency | 47–63 Hz |
| Input Current | Typ 3.4 mA @ 24 VAC/VDC |
| Maximum Input Current | 5.0 mA @ 27.6 VAC/VDC |
| Input Impedance | 6.8 K Ω @ 24 VAC/VDC |
| ON Voltage Level | > 18.0 VAC/VDC |
| OFF Voltage Level | < 4.0 VAC/VDC |
| Minimum ON Current | 2.5 mA |
| Maximum OFF Current | 0.5 mA |
| OFF to ON Response | 5–40 ms |
| ON to OFF Response | 10–50 ms |
| Status Indicators | Logic Side (8 points, green LED) Power Indicator (green LED) |
| Commons | 2 (4 points/common) Isolated |
| Bus Power Required (24VDC) | Max. 30mA (All Inputs On) |
| Terminal Block Replacement | AutomationDirect p/n C0-8TB |
| Weight | 2.9 oz (82g) |



NOTE: When using this module you must also use CLICK programming software version V1.20 or later.

Equivalent Input Circuit

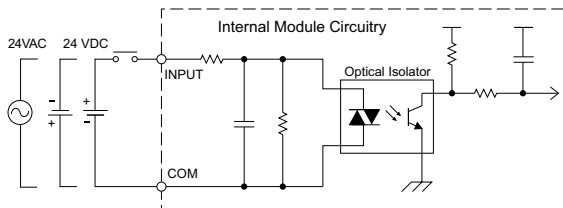

Input Module Temperature Derating Chart

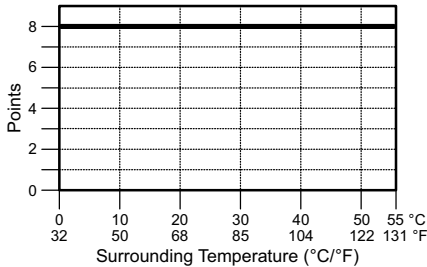

ZILink Pre-Wired PLC Connection Cables and Modules for CLICK PLC

- 11-pin connector cable
- ZL-C0-CBL11 (0.5 m length)
- ZL-C0-CBL11-1 (1.0 m length)
- ZL-C0-CBL11-2 (2.0 m length)



- ZL-RTB20
- 20-pin feed-through connector module



C0-16NE3 – 16-Point Sink/Source AC/DC Input Module

16-point 24VAC / 24VDC current sinking or sourcing input module, 4 commons, 4 points per common, removable terminal block included.

Wiring Diagram

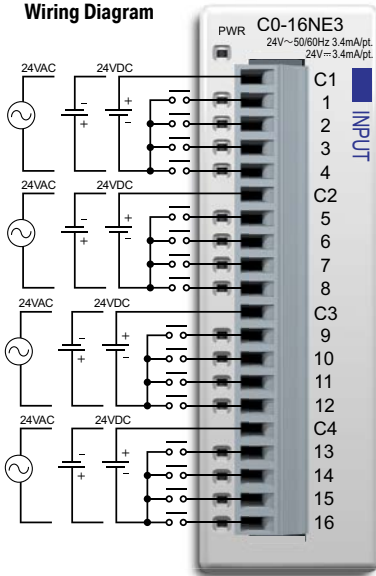

Input Specifications

| | |
|-----------------------------------|--|
| Inputs per Module | 16 (Sink/Source) |
| Operating Voltage Range | 24 VAC/VDC |
| Input Voltage Range | 20.4–27.6 VAC/VDC |
| Peak Voltage | 27.6 VAC/VDC |
| AC Frequency | 47–63 Hz |
| Input Current | Typ 3.4 mA @ 24 VAC/VDC |
| Maximum Input Current | 5.0 mA @ 27.6 VAC/VDC |
| Input Impedance | 6.8 kΩ @ 24 VAC/VDC |
| ON Voltage Level | > 18.0 VAC/VDC |
| OFF Voltage Level | < 4.0 VAC/VDC |
| Minimum ON Current | 2.5 mA |
| Maximum OFF Current | 0.5 mA |
| OFF to ON Response | 5–40 ms |
| ON to OFF Response | 10–50 ms |
| Status Indicators | Logic Side (16 points, green LED) Power Indicator (green LED) |
| Commons | 4 (4 points/common) Isolated |
| Bus Power Required (24VDC) | Max. 40mA (All Inputs On) |
| Terminal Block Replacement | AutomationDirect p/n C0-16TB |
| Weight | 3.2 oz (90g) |



NOTE: When using this module you must also use CLICK programming software version V1.20 or later.

ZIPLink Pre-Wired PLC Connection Cables and Modules for CLICK PLC

Equivalent Input Circuit

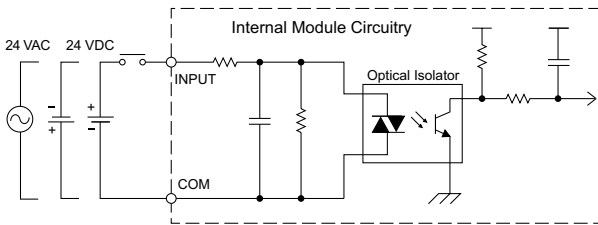

20-pin connector cable
 ZL-C0-CBL20 (0.5 m length)
 ZL-C0-CBL20-1 (1.0 m length)
 ZL-C0-CBL20-2 (2.0 m length)

Input Module Temperature Derating Chart

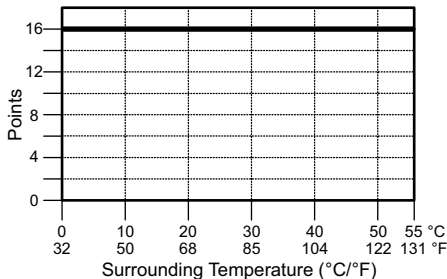

ZL-RTB20 20-pin feed-through connector module



ZL-LTB16-24-1 sensor input module

C0-08NA – 8-Point AC Input Module

8-point 100–120 VAC input module, 2 commons, isolated, removable terminal block included.

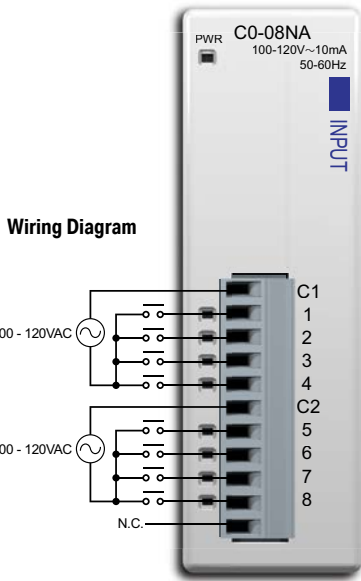

Wiring Diagram

N.C. = Not Connected

| Input Specifications | |
|-----------------------------------|---|
| Inputs per Module | 8 |
| Operating Voltage Range | 100–120 VAC |
| Input Voltage Range | 80–144 VAC |
| AC Frequency | 47–63 Hz |
| Input Current | Typ 8.5 mA @ 100VAC (50Hz) Typ 10mA @ 100VAC (60Hz) |
| Maximum Input Current | 16mA @ 144VAC |
| Input Impedance | 15kΩ (50 Hz), 12kΩ (60Hz) |
| ON Voltage Level | > 70VAC |
| OFF Voltage Level | < 20VAC |
| Minimum ON Current | 5mA |
| Maximum OFF Current | 2mA |
| OFF to ON Response | < 40ms |
| ON to OFF Response | < 40ms |
| Status Indicators | Logic Side (8 points, green LED) Power Indicator (green LED) |
| Commons | 2 (4 points/common) Isolated |
| Bus Power Required (24VDC) | Max. 30mA (All Inputs On) |
| Terminal Block Replacement | AutomationDirect p/n C0-8TB |
| Weight | 2.8 oz (80g) |

Equivalent Input Circuit

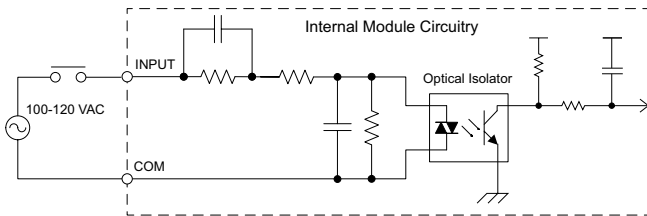

ZIPLink Pre-Wired PLC Connection Cables and Modules for CLICK PLC

- 11-pin connector cable
- ZL-C0-CBL11 (0.5 m length)
- ZL-C0-CBL11-1 (1.0 m length)
- ZL-C0-CBL11-2 (2.0 m length)



Input Module Temperature Derating Chart

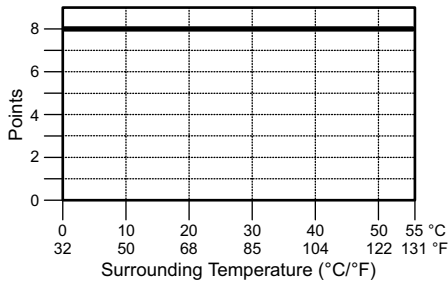

- ZL-RTB20
- 20-pin feed-through connector module



C0-08TD1 – 8-Point Sinking DC Output Module

8-point 3.3–27 VDC current sinking output module, 2 commons, 0.3 A/pt, removable terminal block included.

Wiring Diagram

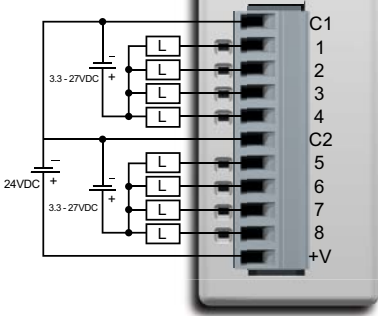

| Output Specifications | |
|----------------------------|---|
| Outputs per Module | 8 (Sink) |
| Operating Voltage Range | 3.3–27 VDC |
| Output Voltage Range | 2.8–30 VDC |
| Maximum Output Current | 0.3 A/point, 1.2 A/common |
| Minimum Output Current | 0.5 mA |
| Maximum Leakage Current | 0.1 mA @ 30.0 VDC |
| On Voltage Drop | 1.5 VDC @ 0.3 A |
| Maximum Inrush Current | 1A for 10ms |
| OFF to ON Response | < 0.5 ms |
| ON to OFF Response | < 0.5 ms |
| Status Indicators | Logic Side (8 points, red LED) Power Indicator (green LED) |
| Commons | 2 (4 points/common) |
| External DC Power Required | 21.6–26.4 VDC Max 15mA (All Outputs On) |
| Bus Power Required (24VDC) | Max. 50mA (All Outputs On) |
| Terminal Block Replacement | AutomationDirect p/n C0-8TB |
| Weight | 2.8 oz (80g) |

Equivalent Output Circuit

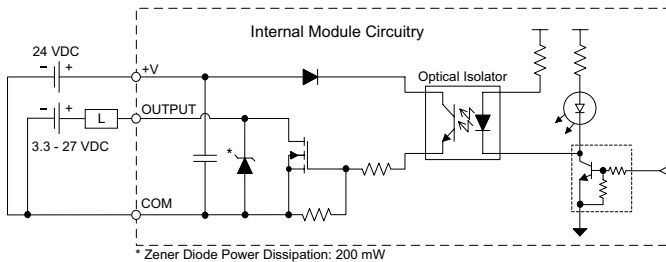

Z/PLink Pre-Wired PLC Connection Cables and Modules for CLICK PLC



- 11-pin connector cable
- ZL-C0-CBL11 (0.5 m length)
- ZL-C0-CBL11-1 (1.0 m length)
- ZL-C0-CBL11-2 (2.0 m length)

Output Module Temperature Derating Chart

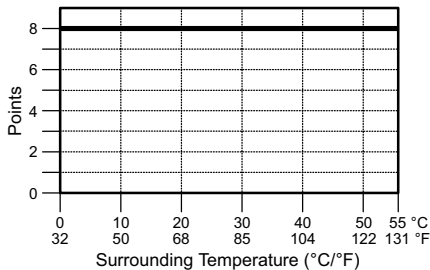

ZL-RTB20
20-pin feed-through
connector module



C0-08TD2 – 8-Point Sourcing DC Output Module

8-point 12–24VDC current sourcing output module, 1 common, 0.3 A/pt, removable terminal block included.

Wiring Diagram

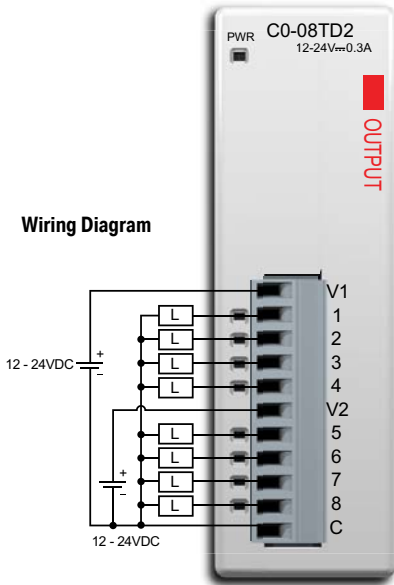

| Output Specifications | |
|----------------------------|---|
| Outputs per Module | 8 (Source) |
| Operating Voltage Range | 12–24VDC |
| Output Voltage Range | 9.6–30 VDC |
| Maximum Output Current | 0.3 A/point, 1.2 A/common |
| Minimum Output Current | 0.5 mA |
| Maximum Leakage Current | 0.1 mA @ 30.0 VDC |
| On Voltage Drop | 1.5 VDC @ 0.3 A |
| Maximum Inrush Current | 1A for 10ms |
| OFF to ON Response | < 1ms |
| ON to OFF Response | < 1ms |
| Status Indicators | Logic Side (8 points, red LED) Power Indicator (green LED) |
| Commons | 1 (8 points/common) |
| Bus Power Required (24VDC) | Max. 50mA (All Outputs On) |
| Terminal Block Replacement | AutomationDirect p/n C0-8TB |
| Weight | 2.8 oz (80g) |

Equivalent Output Circuit

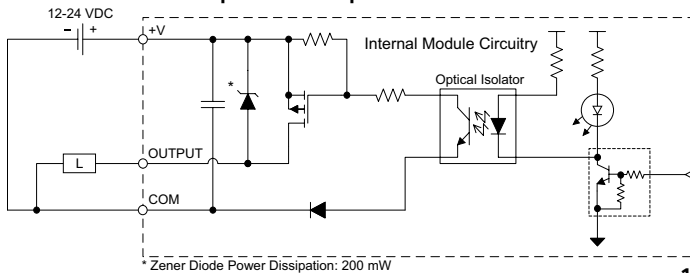

Z/PLink Pre-Wired PLC Connection Cables and Modules for CLICK PLC



- 11-pin connector cable
- ZL-C0-CBL11 (0.5 m length)
- ZL-C0-CBL11-1 (1.0 m length)
- ZL-C0-CBL11-2 (2.0 m length)

Output Module Temperature Derating Chart

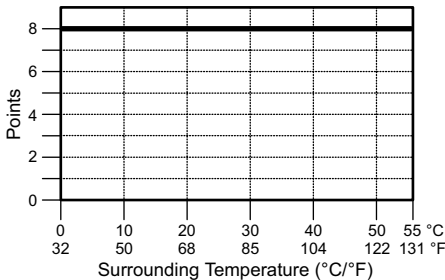

ZL-RTB20
20-pin feed-through connector module



C0-16TD1 – 16-Point Sinking DC Output Module

16-point 5–27 VDC current sinking output module, 2 commons, isolated, 0.1 A/pt, removable terminal block included.

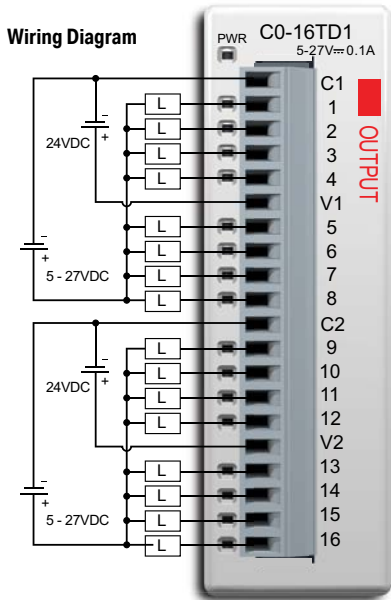

| Output Specifications | |
|----------------------------|--|
| Outputs per Module | 16 (Sink) |
| Operating Voltage Range | 5–27 VDC |
| Output Voltage Range | 4–30 VDC |
| Maximum Output Current | 0.1 A/point, 0.8 A/common |
| Minimum Output Current | 0.2 mA |
| Maximum Leakage Current | 0.1 mA @ 30.0 VDC |
| On Voltage Drop | 0.5 VDC @ 0.1 A |
| Maximum Inrush Current | 150mA for 10ms |
| OFF to ON Response | < 0.5 ms |
| ON to OFF Response | < 0.5 ms |
| Status Indicators | Logic Side (16 points, red LED) Power Indicator (green LED) |
| Commons | 2 (8 Points/common) Isolated |
| External DC Power Required | 21.6–26.4 VDC Max 100mA (All Outputs On) |
| Bus Power Required (24VDC) | Max. 80mA (All Outputs On) |
| Terminal Block Replacement | AutomationDirect p/n C0-16TB |
| Weight | 3.2 oz (90g) |

Equivalent Output Circuit

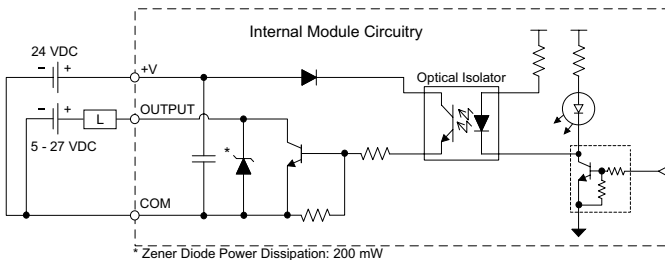

ZIPLink Pre-Wired PLC Connection Cables and Modules for CLICK PLC



- 20-pin connector cable
- ZL-C0-CBL20 (0.5 m length)
- ZL-C0-CBL20-1 (1.0 m length)
- ZL-C0-CBL20-2 (2.0 m length)

Output Module Temperature Derating Chart

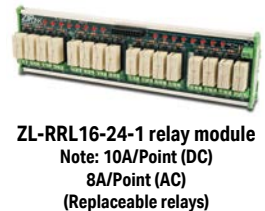
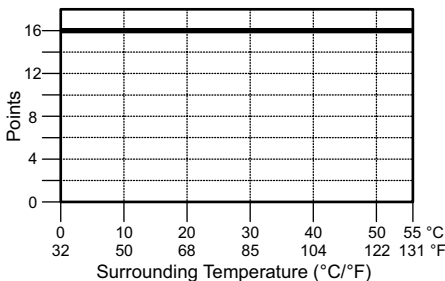

C0-16TD2 – 16-Point Sourcing Output Module

16-point 12–24 VDC current sourcing output module, 2 commons, isolated, 0.1 A/pt, removable terminal block included.

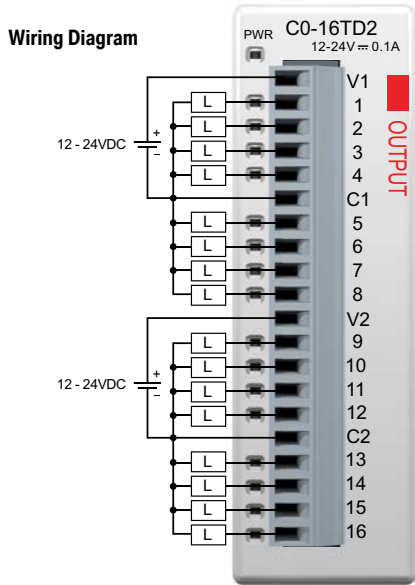

| Output Specifications | |
|----------------------------|--|
| Outputs per Module | 16 (Source) |
| Operating Voltage Range | 12-24VDC |
| Output Voltage Range | 9.6-30.0 VDC |
| Maximum Output Current | 0.1 A/point , 0.8 A/common |
| Minimum Output Current | 0.2 mA |
| Maximum Leakage Current | 0.1 mA @ 30.0 VDC |
| On Voltage Drop | 0.6 VDC @ 0.1 A |
| Maximum Inrush Current | 150mA for 10ms |
| OFF to ON Response | < 0.5 ms |
| ON to OFF Response | < 0.5 ms |
| Status Indicators | Logic Side (16 points, red LED) Power Indicator (green LED) |
| Commons | 2 (8 points/common) Isolated |
| Bus Power Required (24VDC) | Max. 80mA (All Outputs On) |
| Terminal Block Replacement | AutomationDirect p/n C0-16TB |
| Weight | 3.2 oz (90g) |

Equivalent Output Circuit

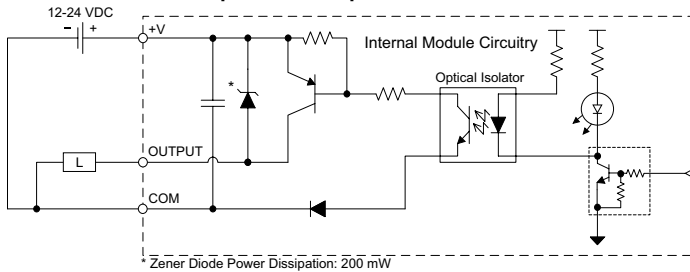

ZIPLink Pre-Wired PLC Connection Cables and Modules for CLICK PLC



- 20-pin connector cable
- ZL-C0-CBL20 (0.5 m length)
- ZL-C0-CBL20-1 (1.0 m length)
- ZL-C0-CBL20-2 (2.0 m length)

Output Module Temperature Derating Chart

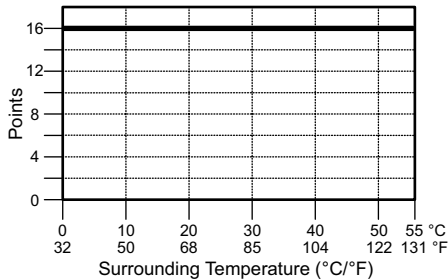

C0-08TA – 8-Point AC Output Module

8-point 17-240 VAC triac output module, 2 commons, isolated, 0.3 A/pt, removable terminal block included.

Wiring Diagram

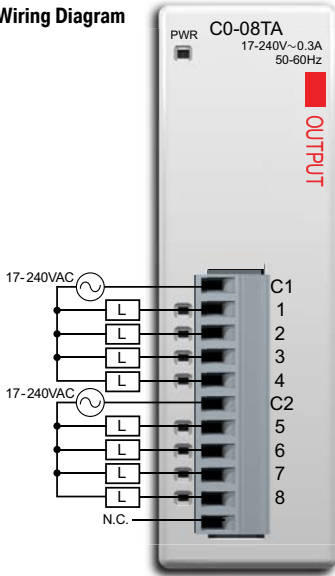

N.C. = Not Connected

| Output Specifications | |
|----------------------------|--|
| Outputs per Module | 8 |
| Operating Voltage Range | 17-240 VAC |
| Output Voltage Range | 13.5-288 VAC |
| AC Frequency | 47-63 Hz |
| Maximum Output Current | 0.3 A/point, 1.2 A/common |
| Minimum Load | 10mA |
| Maximum Leakage Current | 4mA @ 288 VAC |
| On Voltage Drop | 1.5 VAC @ > 0.1 A 3.0 VAC @ < 0.1 A |
| Maximum Inrush Current | 10A for 10ms |
| OFF to ON Response | 1ms |
| ON to OFF Response | 1ms + 1/2 cycle |
| Status Indicators | Logic Side (8 points, red LED) Power Indicator (green LED) |
| Commons | 2 (4 points/common) Isolated |
| Bus Power Required (24VDC) | Max. 80mA (All Outputs On) |
| Protection Circuit | Not built into the module - Install protection elements such as external fuse. |
| Terminal Block Replacement | AutomationDirect p/n C0-8TB |
| Weight | 3.5 oz (100g) |

Equivalent Output Circuit

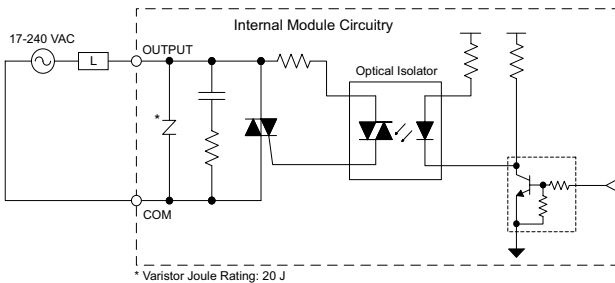

Z/PLink Pre-Wired PLC Connection Cables and Modules for CLICK PLC



- 11-pin connector cable
- ZL-C0-CBL11 (0.5 m length)
- ZL-C0-CBL11-1 (1.0 m length)
- ZL-C0-CBL11-2 (2.0 m length)

Output Temperature Derating Chart

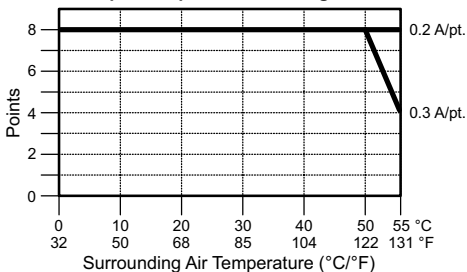

* Use every other output.

ZL-RTB20
20-pin feed-through connector module



CO-04TRS – 4-Point Relay Output Module

4-point 6–240 VAC / 6–27VDC Isolated relay output module, 4 Form C (SPDT) relays, 4 isolated commons, 7 A/point, removable terminal block included.

Wiring Diagram

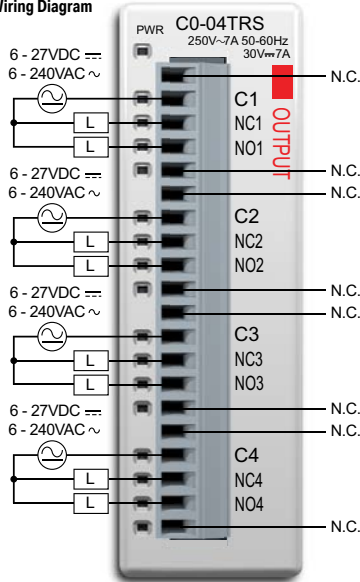

N.C. = Not Connected

| Output Specifications | |
|----------------------------|--|
| Outputs per Module | 4 |
| Operating Voltage Range | 6–27 VDC / 6–240 VAC |
| Output Voltage Range | 5–30 VDC / 5–264 VAC |
| Output Type | Relay, form C (SPDT) |
| AC Frequency | 47–63 Hz |
| Maximum Current | 7A / point, 7A / common |
| Minimum Load Current | 100mA @ 5VDC |
| Maximum Leakage Current | 0.1 mA @ 264VAC |
| Maximum Inrush Current | 12A |
| OFF to ON Response | < 15ms |
| ON to OFF Response | < 15ms |
| Status Indicators | Logic Side (4 points, red LED) Power Indicator (green LED) |
| Commons | 4 (1 point/common) Isolated |
| Bus Power Required (24VDC) | Max. 100mA (All Outputs On) |
| Protection Circuit | Not built into the module - Install protection elements such as external fuse. |
| Terminal Block Replacement | AutomationDirect p/n CO-16TB |
| Weight | 4.4 oz (125g) |

Equivalent Output Circuit

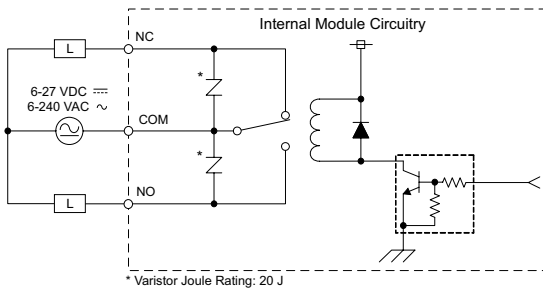

| Typical Relay Life (Operations) at Room Temperature | |
|---|----------------|
| Voltage & Load Type | Relay Life |
| 30VDC, 7A Resistive | 100,000 cycles |
| 250VAC, 7A Resistive | 100,000 cycles |
| 250VAC, 4.9 A Solenoid | 90,000 cycles |
| 250VAC, 2.9 A Solenoid | 100,000 cycles |
| ON to OFF = 1 cycle | |

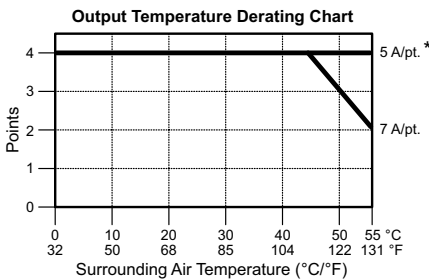

* No derating when the load current is 5A or less for each output point.

NOTE: The CO-04TRS relay output module is derated to 2A per point maximum when used with the ZIPLink wiring system.

ZIPLink Pre-Wired PLC Connection Cables and Modules for CLICK PLC



- 20-pin connector cable
- ZL-C0-CBL20 (0.5 m length)
- ZL-C0-CBL20-1 (1.0 m length)
- ZL-C0-CBL20-2 (2.0 m length)

ZL-RTB20 20-pin feed-through connector module

C0-04TRS-10 – 4-Point Relay Output Module

4-point 6–240 VAC / 6–24VDC Isolated relay output module, 4 Form A (SPST) relays, 4 isolated commons, 10A/point, removable terminal block included.

Wiring Diagram

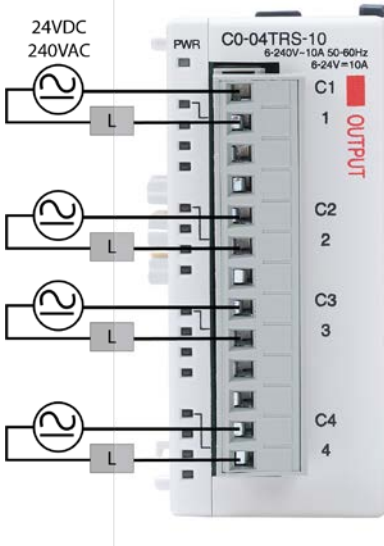

Output Specifications

| | |
|-----------------------------------|--|
| Outputs per Module | 4 |
| Operating Voltage Range | 6–24 VDC / 6–240 VAC |
| Peak Voltage | 24VDC / 264VAC |
| Output Type | Relay, form A (SPST) |
| AC Frequency | 47–63 Hz |
| Maximum Current | 10A / point, 10A / common |
| Minimum Load Current | 100mA @ 5VDC |
| Maximum Inrush Current | 16A for 10ms |
| OFF to ON Response | < 15ms |
| ON to OFF Response | < 15ms |
| Status Indicators | Logic Side (4 points, red LED) Power Indicator (green LED) |
| Commons | 4 (1 point/common) Isolated |
| Bus Power Required (24VDC) | Max. 120mA (All Outputs On) |
| Protection Circuit | Not built into the module - Install protection elements such as external fuse. |
| Terminal Block Replacement | AutomationDirect p/n C0-8TB-1 |
| Weight | 5.22 oz (148g) |

Typical Relay Life (Operations) at Room Temperature

| Voltage & Load Type | Relay Life |
|-----------------------|----------------|
| 24VDC, 10A Resistive | 120,000 cycles |
| 24VDC, 10A Inductive | 60,000 cycles |
| 110VAC, 10A Resistive | 120,000 cycles |
| 110VAC, 10A Inductive | 35,000 cycles |
| 220VAC, 10A Resistive | 120,000 cycles |
| 220VAC, 10A Inductive | 35,000 cycles |

ON to OFF = 1 cycle

Output Temperature Derating Chart

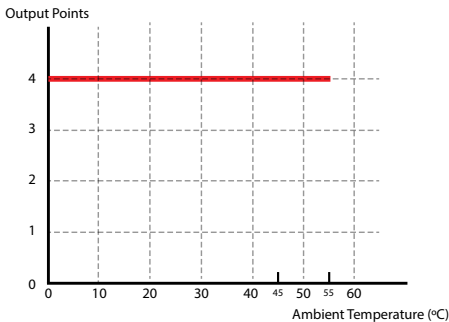

Equivalent Output Circuit

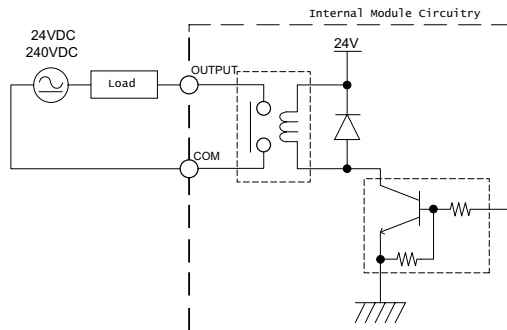

C0-08TR – 8-Point Relay Output Module

8-point 6–240 VAC /6–27 VDC relay output module, 8 Form A (SPST) relays, 2 commons, isolated, 4 A/common, removable terminal block included.

Wiring Diagram

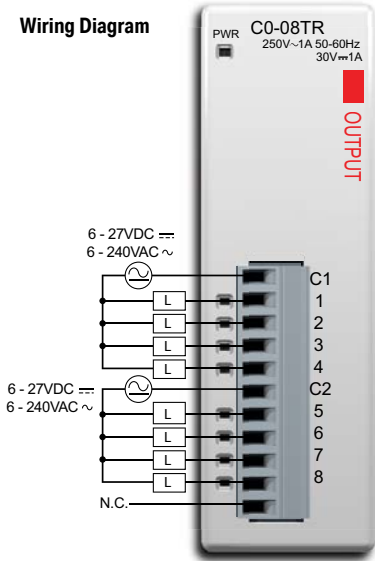

N.C. = Not Connected

| Output Specifications | |
|-----------------------------|--|
| Outputs per Module | 8 |
| Operating Voltage Range | 6-27 VDC / 6-240 VAC |
| Output Voltage Range | 5-30 VDC / 5-264 VAC |
| Output Type | Relay, form A (SPST) |
| AC Frequency | 47-63 Hz |
| Maximum Current (resistive) | 1A /point, 4A /common |
| Minimum Load Current | 5mA @ 5VDC |
| Maximum Leakage Current | 0.1 mA @ 264VAC |
| Maximum Inrush Current | 3A for 10ms |
| OFF to ON Response | < 15ms |
| ON to OFF Response | < 15ms |
| Status Indicators | Logic Side (8 points, red LED) Power Indicator (green LED) |
| Commons | 2 (4 points/common) Isolated |
| Bus Power Required (24VDC) | Max. 100mA (All Outputs On) |
| Protection Circuit | Not built into the module - Install protection elements such as external fuse. |
| Terminal Block Replacement | AutomationDirect p/n C0-8TB |
| Weight | 3.9 oz (110g) |

Equivalent Output Circuit

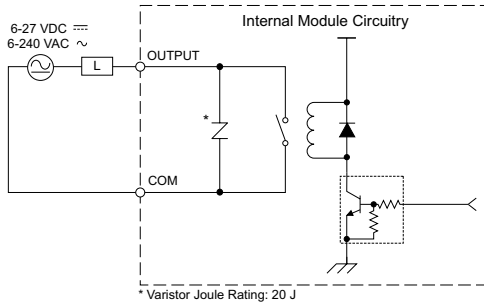

| Typical Relay Life (Operations) at Room Temperature | |
|---|----------------|
| Voltage & Load Type | Relay Life |
| 30VDC, 1A Resistive | 300,000 cycles |
| 30VDC, 1A Solenoid | 50,000 cycles |
| 250VAC, 1A Resistive | 500,000 cycles |
| 250VAC, 1A Solenoid | 200,000 cycles |
| ON to OFF = 1 cycle | |

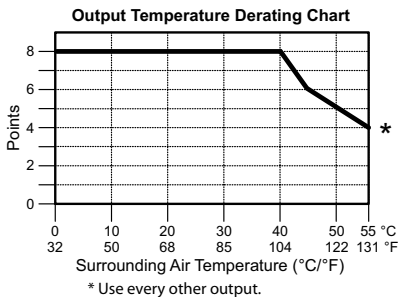

ZIPLink Pre-Wired PLC Connection Cables and Modules for CLICK PLC



- 11-pin connector cable
- ZL-C0-CBL11 (0.5 m length)
- ZL-C0-CBL11-1 (1.0 m length)
- ZL-C0-CBL11-2 (2.0 m length)



ZL-RTB20
20-pin feed-through connector module



NOTE: The C0-08TR is derated to 2A maximum per Common when used with the ZIPLink wiring system.

C0-08TR-3 – 8-Point Relay Output Module

8-point 6–240 VAC /6–27 VDC relay output module, 8 Form A (SPST) relays, 4 commons, isolated, 3A/point, removable terminal block included.

Wiring Diagram

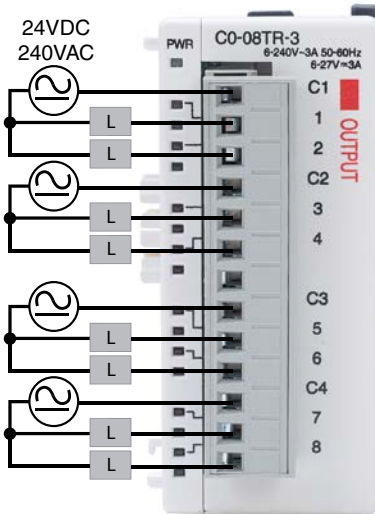

Output Specifications

| | |
|------------------------------------|--|
| Outputs per Module | 8 |
| Operating Voltage Range | 6–27 VDC / 6–240 VAC |
| Peak Voltage | 30 VDC / 264 VAC |
| Output Type | Relay, form A (SPST) |
| AC Frequency | 47–63 Hz |
| Maximum Current (resistive) | 3A /point, 6A /common |
| Minimum Load Current | 5mA @ 5VDC |
| Maximum Inrush Current | 5A for 10ms |
| OFF to ON Response | < 15ms |
| ON to OFF Response | < 15ms |
| Status Indicators | Logic Side (8 points, red LED) Power Indicator (green LED) |
| Commons | 4 (2 points/common) Isolated |
| Bus Power Required (24VDC) | Max. 90mA (All Outputs ON) |
| Protection Circuit | Not built into the module - Install protection elements such as external fuse. |
| Terminal Block Replacement | AutomationDirect p/n C0-8TB-1 |
| Weight | 4.12 oz (117g) |

Typical Relay Life (Operations) at Room Temperature

| Voltage & Load Type | Relay Life |
|----------------------|----------------|
| 24VDC, 3A Resistive | 100,000 cycles |
| 24VDC, 3A Inductive | 50,000 cycles |
| 110VAC, 3A Resistive | 100,000 cycles |
| 110VAC, 3A Inductive | 25,000 cycles |
| 220VAC, 3A Resistive | 100,000 cycles |
| 220VAC, 3A Inductive | 25,000 cycles |

ON to OFF = 1 cycle

Output Temperature Derating Chart

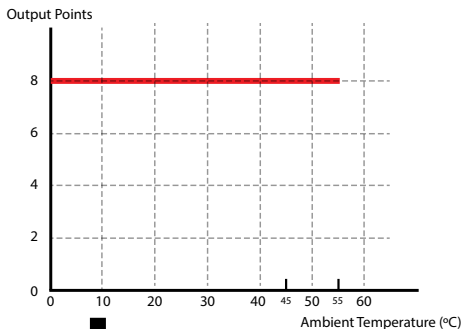

Equivalent Output Circuit

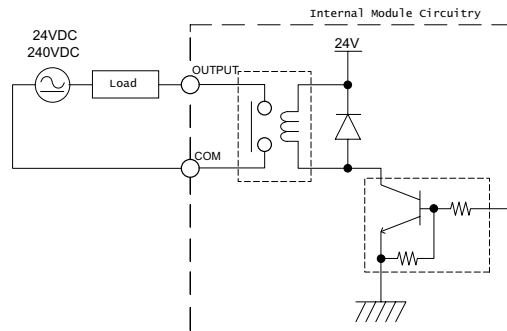

C0-16CDD1 – 8-Point DC Input and 8-Point DC Sinking Output Module

8-point 24VDC current sinking/sourcing input, 1 common, 8-point 5–27 VDC sinking output, 0.1A/pt., 1 common, non-fused, removable terminal block included.

Wiring Diagram

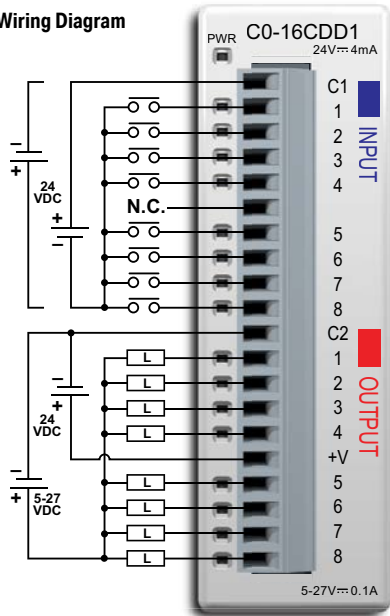

N.C. = Not Connected

| Input Specifications | |
|-------------------------|---|
| Inputs per Module | 8 (Source/Sink) |
| Operating Voltage Range | CE: 24VDC (-10%/+10%) UL: 24VDC (-10%/+10%) |
| Input Voltage Range | 21.6–26.4 VDC |
| Input Current | Typ 4.0 mA @ 24VDC |
| Maximum Input Current | 5.0 mA @ 26.4 VDC |
| Input Impedance | 6.8 kΩ @ 24VDC |
| ON Voltage Level | >19.0 VDC |
| OFF Voltage Level | <7.0 VDC |
| Minimum ON Current | 3.5 mA |
| Maximum OFF Current | 0.5 mA |
| OFF to ON Response | Max. 10ms Typ 2ms |
| ON to OFF Response | Max. 10ms Typ 3ms |
| Status Indicators | Logic Side (8 points, green LED) Power Indicator (green LED) |
| Commons | 1 (8 points/common) |

| General Specifications | |
|----------------------------|------------------------------|
| Bus Power Required (24VDC) | Max. 80mA (all points on) |
| Terminal Block Replacement | AutomationDirect p/n C0-16TB |
| Weight | 3.2 oz (90g) |



NOTE: When using this module you must also use CLICK programming software and PLC firmware version V1.40 or later.

Equivalent Input Circuit

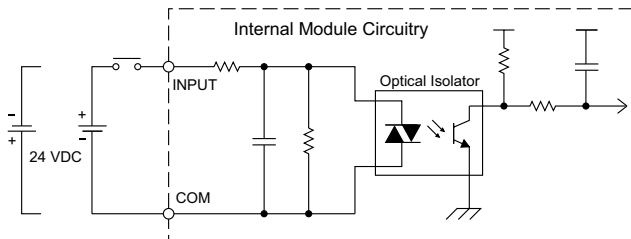

Input Module Temperature Derating Chart

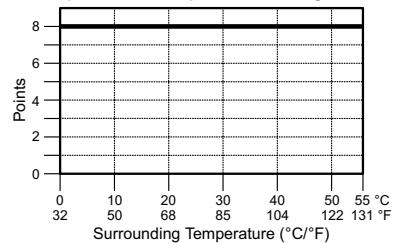

C0-16CDD1 (continued)

| Output Specifications | |
|----------------------------|--|
| Outputs per Module | 8 (sink) |
| Operating Voltage Range | CE: 5-24 VDC (-15%/+20%) |
| | UL: 5-27 VDC (-15%/+20%) |
| Output Voltage Range | 4-30 VDC |
| Maximum Output Current | 0.1 A/point, 0.8 A/common |
| Minimum Output Current | 0.2 mA |
| Maximum Leakage Current | 0.1 mA @ 30VDC |
| On Voltage Drop | 0.5 VDC @ 0.1 A |
| Maximum Inrush Current | 0.15 A for 10ms |
| OFF to ON Response | < 0.5 ms |
| ON to OFF Response | < 0.5 ms |
| Status Indicators | Logic Side (8 points, red LED) |
| Commons | 1 (8 points/common) |
| External DC Power Required | 24VDC (-10%/+10%) max. 50mA (all points on) |

Equivalent Output Circuit

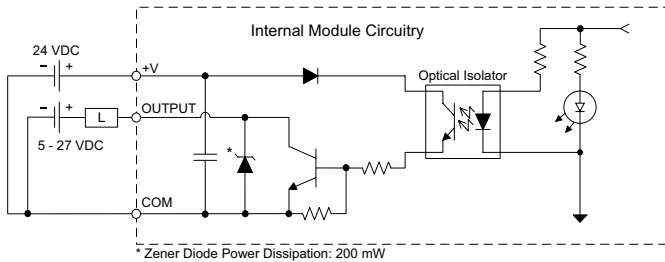

Output Module Temperature Derating Chart

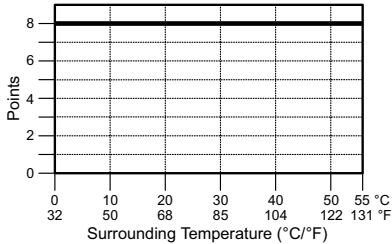

ZIPLink Pre-Wired PLC Connection Cables and Modules for CLICK PLC



ZL-RTB20
20-pin feed-through connector module

- 20-pin connector cable ZL-C0-CBL20 (0.5 m length)
- ZL-C0-CBL20-1 (1.0 m length)
- ZL-C0-CBL20-2 (2.0 m length)



C0-16CDD2 – 8-Point DC Input and 8-Point DC Sourcing Output Module

8-point 24VDC current sinking/sourcing input, 1 common, 8-point 12–24 VDC sourcing output, 0.1A/pt, 1 common, non-fused, removable terminal block included.

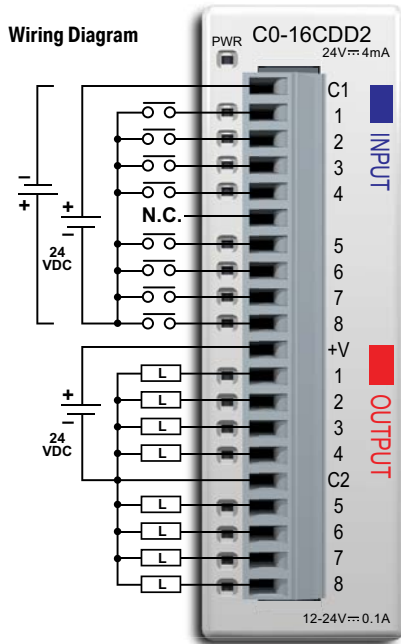

N.C. = Not Connected

| Input Specifications | |
|--------------------------------|---|
| Inputs per Module | 8 (source/sink) |
| Operating Voltage Range | CE: 24VDC (-10%/+10%) UL: 24VDC (-10%/+10%) |
| Input Voltage Range | 21.6–26.4 VDC |
| Input Current | Typ 4.0 mA @ 24VDC |
| Maximum Input Current | 5.0 mA @ 26.4 VDC |
| Input Impedance | 6.8 kΩ @ 24VDC |
| ON Voltage Level | >19.0 VDC |
| OFF Voltage Level | <7.0 VDC |
| Minimum ON Current | 3.5 mA |
| Maximum OFF Current | 0.5 mA |
| OFF to ON Response | Max. 10ms Typ 2ms |
| ON to OFF Response | Max. 10ms Typ 3ms |
| Status Indicators | Logic Side (8 points, green LED) Power Indicator (green LED) |
| Commons | 1 (8 points/common) |

| General Specifications | |
|-----------------------------------|------------------------------|
| Bus Power Required (24VDC) | Max. 80mA (all points on) |
| Terminal Block Replacement | AutomationDirect p/n C0-16TB |
| Weight | 3.2 oz (90g) |



NOTE: When using this module you must also use CLICK programming software and PLC firmware version V1.40 or later.

Equivalent Input Circuit

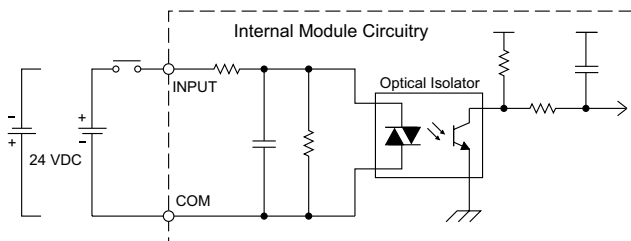

Input Module Temperature Derating Chart

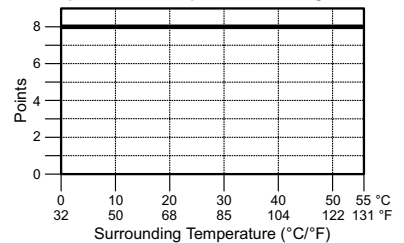

C0-16CDD2 (continued)

| Output Specifications | |
|-------------------------|--|
| Outputs per Module | 8 (Source) |
| Operating Voltage Range | CE: 12–24 VDC (-15%/+20%) UL: 12–24 VDC (-20%/+25%) |
| Output Voltage Range | 9.6–30 VDC |
| Maximum Output Current | 0.1 A/point, 0.8 A/common |
| Minimum Output Current | 0.2 mA |
| Maximum Leakage Current | 0.1 mA @ 30VDC |
| On Voltage Drop | 0.6 VDC @ 0.1 A |
| Maximum Inrush Current | 0.15 A for 10ms |
| OFF to ON Response | <0.5 ms |
| ON to OFF Response | <0.5 ms |
| Status Indicators | Logic Side (8 points, red LED) |
| Commons | 1 (8 points/common) |

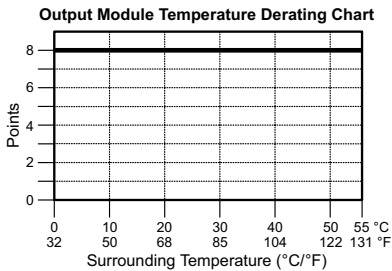
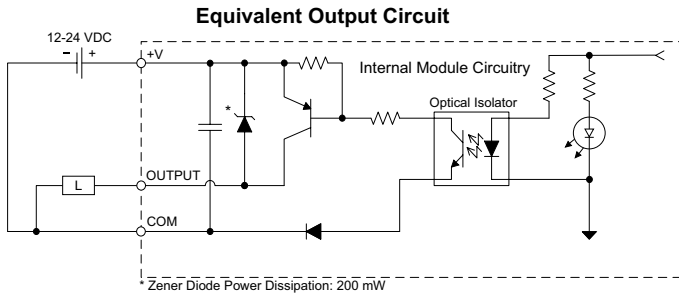

ZIPLink Pre-Wired PLC Connection Cables and Modules for CLICK PLC



ZL-RTB20
20-pin feed-through connector module

- 20-pin connector cable
- ZL-C0-CBL20 (0.5 m length)
- ZL-C0-CBL20-1 (1.0 m length)
- ZL-C0-CBL20-2 (2.0 m length)



C0-08CDR – 4-Point DC Input and 4-Point Relay Output Module

4-point 12–24 VDC current sinking/sourcing input, 1 common, 4-point 6.25–24 VDC / 6–240 VAC relay output, Form A (SPST) relays 1A/pt, 1 common, non-fused, removable terminal block included.

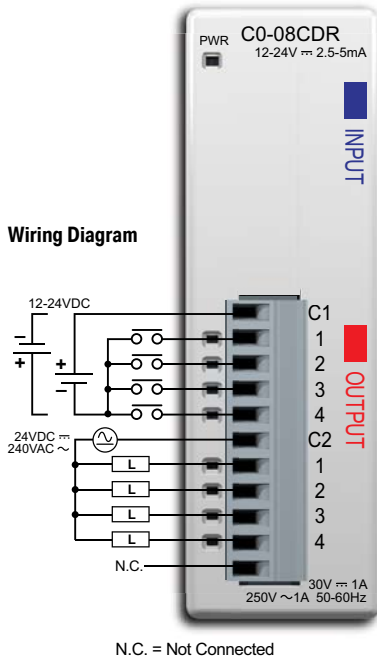

| Input Specifications | |
|-------------------------|---|
| Inputs per Module | 4 (source/sink) |
| Operating Voltage Range | CE: 12–24 VDC (-10%/+10%) UL: 12–24 VDC (-10%/+10%) |
| Input Voltage Range | 10.8–26.4 VDC |
| Input Current | Typ 5.0 mA @ 24VDC |
| Maximum Input Current | 7.0 mA @ 26.4 VDC |
| Input Impedance | 4.7 kΩ @ 24VDC |
| ON Voltage Level | >8.0 VDC |
| OFF Voltage Level | <3.0 VDC |
| Minimum ON Current | 1.4 mA |
| Maximum OFF Current | 0.5 mA |
| OFF to ON Response | Max. 3.5 ms Typ 2ms |
| ON to OFF Response | Max. 4ms Typ 2.5 ms |
| Status Indicators | Logic Side (4 points, green LED) Power Indicator (green LED) |
| Commons | 1 (4 points/common) |

| General Specifications | |
|----------------------------|---|
| Bus Power Required (24VDC) | Max. 80mA (all points on) |
| Protection Circuit | Not built into the module - Install protection elements such as external fuse |
| Terminal Block Replacement | AutomationDirect p/n C0-8TB |
| Weight | 3.2 oz (90g) |



NOTE: When using this module you must also use CLICK programming software and PLC firmware version V1.40 or later.

Equivalent Input Circuit

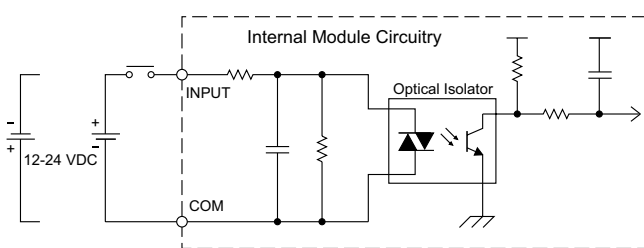

Input Temperature Derating Chart

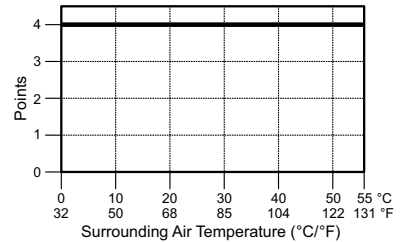

C0-08CDR (continued)

| Output Specifications | |
|-------------------------|---|
| Outputs per Module | 4 (Relay) |
| Operating Voltage Range | CE: 6.25–24 VDC (-15%/+10%) / 6–240 VAC (-15%/+10%) UL: 24VDC (-15%/+10%) / 240VAC (-10%/+10%) |
| Peak Voltage | 30VDC / 264VAC |
| Output Type | Relay, Form A (SPST) |
| AC Frequency | 47–63 Hz |
| Maximum Current | 1A /point, 4 A/common |
| Minimum Load Current | 5mA @ 5VDC |
| Maximum Leakage Current | 0.1 mA @ 264VAC |
| Maximum Inrush Current | 3A for 10ms |
| OFF to ON Response | <15ms |
| ON to OFF Response | <15ms |
| Status Indicators | Logic Side (4 points, red LED) |
| Commons | 1 (4 points/common) |

| Typical Relay Life (Operations) at Room Temperature | |
|---|----------------------------------|
| Voltage & Load Type* | Relay Life (ON to OFF = 1 cycle) |
| 30VDC, 1A, Resistive | 80,000 cycles |
| 30VDC, 1A, Solenoid | 80,000 cycles |
| 250VAC, 1A, Resistive | 80,000 cycles |
| 250VAC, 1A, Solenoid | 80,000 cycles |

* These relay outputs support both inductive (solenoid) and resistive loads.

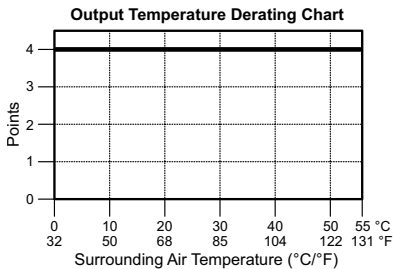
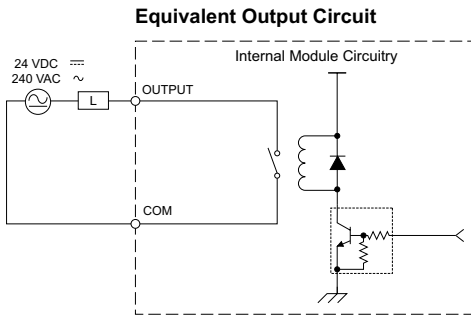

ZIPLink Pre-Wired PLC Connection Cables and Modules for CLICK PLC



ZL-RTB20
20-pin feed-through connector module



11-pin connector cable
ZL-C0-CBL11 (0.5 m length)
ZL-C0-CBL11-1 (1.0 m length)
ZL-C0-CBL11-2 (2.0 m length)

C0-04AD-1 – 4-Channel Analog Current Input Module

4-channel analog current sinking input module, 13-bit resolution, range: 0–20 mA. External 24VDC power required, removable terminal block included.

Wiring Diagram

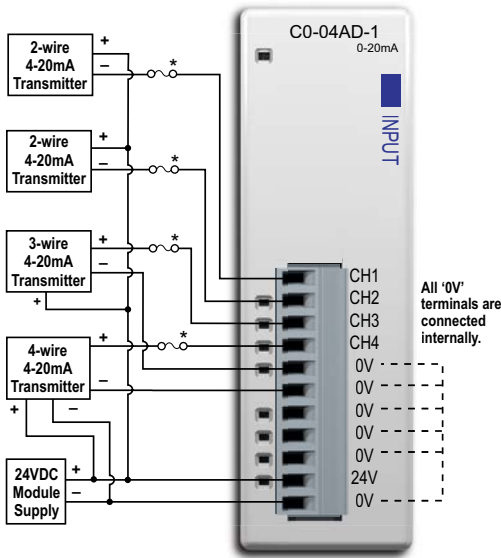

NOTE: When using this module you must also use CLICK programming software and PLC firmware version V1.40 or later.

| Input Specifications | |
|---|--|
| Inputs per Module | 4 |
| Input Range | 0–20 mA (sink) |
| Resolution | 13-bit, 2.44 μ A/count |
| Input Type | Single ended (one common) |
| Maximum Continuous Overload | \pm 44mA |
| Input Impedance | 124 Ω , 0.5 W current input |
| Filter Characteristics | Low pass, -3 dB at 120Hz |
| Sample Duration Time | 2ms |
| All Channel Update Rate | 25ms |
| Open Circuit Detection Time | Zero reading within 100ms |
| Accuracy vs. Temperature | \pm 75 PPM/ $^{\circ}$ C maximum |
| Maximum Inaccuracy | 0.5% of range (including temperature changes) |
| Linearity Error (End to End) | \pm 3 count maximum, monotonic with no missing codes |
| Input Stability and Repeatability | \pm 2 count maximum |
| Full Scale Calibration Error (including Offset) | \pm 8 count maximum |
| Offset Calibration Error | \pm 8 count maximum |
| Maximum Crosstalk at DC, 50/60 Hz | \pm 2 count maximum |
| Field to Logic Side Isolation | 1800VAC for 1 sec. |
| Recommended Fuse (external) | AutomationDirect p/n S500-32-R (0.032A fuse) |
| External 24VDC Power Required | 65mA |
| Bus Power Required (24VDC) | 20mA |
| Terminal Block Replacement | AutomationDirect p/n C0-8TB |
| Weight | 2.9 oz (82g) |

Z/PLink Pre-Wired PLC Connection Cables and Modules for CLICK PLC



ZL-RTB20 20-pin feed-through connector module



11-pin connector cable
 ZL-C0-CBL11 (0.5 m length)
 ZL-C0-CBL11-1 (1.0 m length)
 ZL-C0-CBL11-2 (2.0 m length)

C0-04AD-2 – 4-Channel Analog Voltage Input Module

4-channel analog voltage input module, 13-bit resolution, range: 0–10V. External 24VDC power required, removable terminal block included.

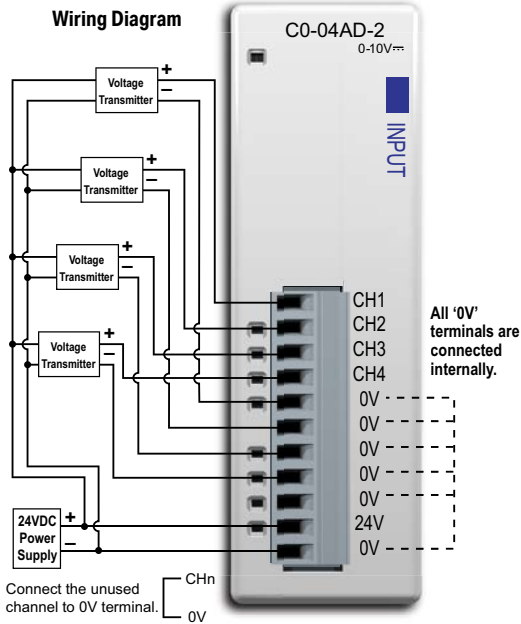

| Input Specifications | |
|---|---|
| Inputs per Module | 4 |
| Input Range | 0–10 V |
| Resolution | 13-bit, 1.22 mV per count |
| Input Type | Single ended (one common) |
| Maximum Continuous Overload | ±100VDC |
| Input Impedance | >150kΩ |
| Filter Characteristics | Low pass, -3 dB at 500Hz |
| Sample Duration Time | 6.25 ms |
| All Channel Update Rate | 25ms |
| Open Circuit Detection Time | Zero reading within 100 ms |
| Accuracy vs. Temperature | ±75 PPM/°C maximum |
| Maximum Inaccuracy | 0.5% of range (including temperature changes) |
| Linearity Error (End to End) | ±3 count maximum, monotonic with no missing codes |
| Input Stability and Repeatability | ±2 count maximum |
| Full Scale Calibration Error (Including Offset) | ±8 count maximum |
| Offset Calibration Error | ±8 count maximum |
| Maximum Crosstalk at DC, 50/60 Hz | ±2 count maximum |
| Field to Logic Side Isolation | 1800VAC for 1 sec. |
| External 24VDC Power Required | 65mA |
| Base Power Required (24VDC) | 23mA |
| Terminal Block Replacement | AutomationDirect p/n C0-8TB |
| Weight | 2.9 oz (82g) |



NOTE: When using this module you must also use CLICK programming software and PLC firmware version V1.40 or later.

ZIPLink Pre-Wired PLC Connection Cables and Modules for CLICK PLC



ZL-RTB20 20-pin feed-through connector module



11-pin connector cable
 ZL-C0-CBL11 (0.5 m length)
 ZL-C0-CBL11-1 (1.0 m length)
 ZL-C0-CBL11-2 (2.0 m length)

C0-04RTD – 4-Channel RTD Input Module

4-channel RTD input module, 16-bit resolution (± 0.1 degrees Celsius or Fahrenheit), supports: Pt100, Pt1000, jPt100, Cu10, Cu25, Ni120. Resistive ranges also supported, removable terminal block included.

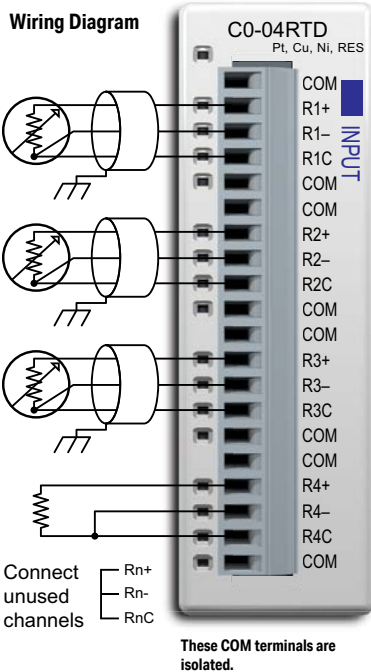

| General Specifications | |
|-------------------------------|------------------------------|
| Field to Logic Side Isolation | No isolation |
| External DC Power Required | None |
| Bus Power Required (24VDC) | 25mA |
| Thermal Dissipation | 2.047 BTU per hour |
| Terminal Block Replacement | AutomationDirect p/n C0-16TB |
| Weight | 3.1 oz (86g) |

| Input Specifications | |
|---|--|
| Inputs per Module | 4 |
| Common Mode Range | ± 2.5 V |
| Common Mode Rejection | 100dB at DC and 100 dB at 50/60 Hz |
| Input Impedance | >5M Ω |
| Maximum Ratings | Fault protected inputs to ± 50 VDC |
| Resolution | $\pm 0.1^\circ\text{C}$ or $^\circ\text{F}$, 0.1 Ω or 0.01 Ω |
| Input Ranges* | Pt100: -200 to 850 $^\circ\text{C}$ (-328 to 1562 $^\circ\text{F}$) |
| | Pt1000: -200 to 595 $^\circ\text{C}$ (-328 to 1103 $^\circ\text{F}$) |
| | jPt100: -100 to 450 $^\circ\text{C}$ (-148 to 842 $^\circ\text{F}$) |
| | 10 Ω Cu: -200 to 260 $^\circ\text{C}$ (-328 to 500 $^\circ\text{F}$) |
| | 25 Ω Cu: -200 to 260 $^\circ\text{C}$ (-328 to 500 $^\circ\text{F}$) |
| | 120 Ω Ni: -80 to 260 $^\circ\text{C}$ (-112 to 500 $^\circ\text{F}$) |
| 0 to 3125.0 Ω : Resolution 0.1 Ω | |
| 0 to 1562.5 Ω : Resolution 0.1 Ω | |
| 0 to 781.2 Ω : Resolution 0.1 Ω | |
| 0 to 390.62 Ω : Resolution 0.01 Ω | |
| 0 to 195.31 Ω : Resolution 0.01 Ω | |
| RTD Linearization | Automatic |
| Excitation Current (All Ranges) | 210 μA |

NOTE: The C0-04RTD module cannot be used with thermistors.

NOTE: When using this module you must also use CLICK programming software and PLC firmware version V1.40 or later.

* While it is possible to use different resistive ranges, we recommend using the narrowest range that covers the resistance being measured. For example, if measuring approximately 100 ohms resistance, use the 0 to 195.31 ohms range. While the resolution is the same as the 0 to 390.62 ohms range, output RMS noise will be lower and stability will be improved.

If there are any unused channels, make sure to select the correct number of channels that you actually use in the C0-04RTD Setting window.

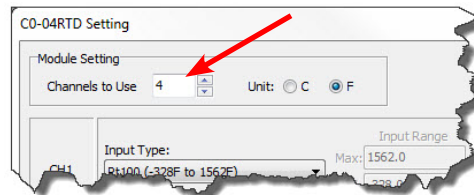

C0-04RTD – 4-Channel RTD Input Module (continued)

| Input Specifications (continued) | |
|---|---|
| Accuracy vs. Temperature | ±10ppm per °C maximum |
| RTD Input Maximum Inaccuracy | ±3°C (excluding RTD error); ±5°C (ranges Cu10 and Cu25) |
| RTD Linearity Error (End to End) | ±2°C maximum, ±0.5°C typical, monotonic with no missing codes |
| Resistance Input Maximum Zero Scale Error | ±0.0015% of full scale range in ohms (negligible) |
| Resistance Input Maximum Full Scale Error | ±0.02% of full scale range |
| Maximum Linearity Error | ±0.015% of full scale range maximum at 25°C, monotonic with no missing codes |
| Resistance Maximum Input Inaccuracy | 0.1% at 0 to 60°C (32° to 140° F), typical 0.04% at 25°C (77° F) |
| Warm Up Time | 30 minutes for ±1C° repeatability |
| Single Channel Update Rate | 240ms |
| All Channel Update Rate | Single Channel Update Rate times the number of enabled channels on the module |
| Open Circuit Detection Time | Positive full-scale reading within 2 seconds |
| Conversion Method | Sigma - Delta |

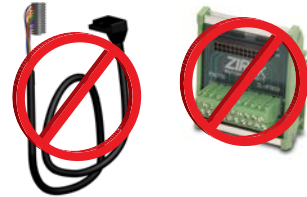

Not Compatible with Z/PLink Pre-Wired PLC Connection Cables and Modules.



NOTE: When this module is used in a CLICK PLC system, it takes up to 24 seconds for initialization after power-up. During this time period, the RUN LED on the PLC module blinks to indicate the initialization process.

| Initialization Time | | |
|-----------------------------|--|--------------------------------|
| The Number of Channels Used | The same Input Type is selected for all Channels | Mixed Input Types are selected |
| 1 | 4 sec | N/A |
| 2 | 5 sec | May take up to 13 sec |
| 3 | 6 sec | May take up to 18 sec |
| 4 | 7 sec | May take up to 24 sec |

C0-04THM – 4-Channel Thermocouple Input Module

4-channel thermocouple input module, 16-bit resolution (± 0.1 degrees Celsius or Fahrenheit), Supports: J, K, E, R, S, T, B, N, C type thermocouples; voltages ranges also supported, removable terminal block included.

Wiring Diagram

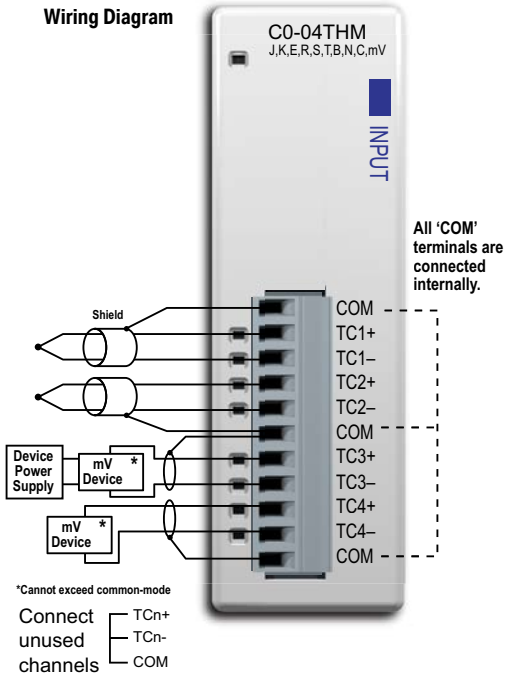

| General Specifications | |
|-------------------------------|---|
| Field to Logic Side Isolation | 1800 VAC applied for 1 second (100% tested) |
| External DC Power Required | None |
| Bus Power Required (24VDC) | 25mA |
| Thermal Dissipation | 0.175 BTU per hour |
| Terminal Block Replacement | AutomationDirect p/n C0-8TB |
| Weight | 3.1 oz (86 g) |

| Input Specifications | |
|-----------------------|--|
| Inputs per Module | 4 |
| Common Mode Range | -1.3 to +3.8 V |
| Common Mode Rejection | 100dB at DC and 130dB at 60Hz |
| Input Impedance | >5MΩ |
| Maximum Ratings | Fault protected inputs to ± 50 VDC |
| Resolution | $\pm 0.1^\circ\text{C}$ or $^\circ\text{F}$, 16-bit |
| Input Ranges | Type J: -190 to 760°C (-310 to 1400°F) |
| | Type K: -150 to 1372°C (-238 to 2502°F) |
| | Type E: -210 to 1000°C (-346 to 1832°F) |
| | Type S: 65 to 1768°C (149 to 3214°F) |
| | Type T: -230 to 400°C (-382 to 752°F) |
| | Type B: 529 to 1820°C (984 to 3308°F) |
| | Type N: -70 to 1300°C (-94 to 2372°F) |
| | Type C: 65 to 2320°C (149 to 4208°F) |
| | 0 to 39.0625 mV |
| | ± 39.0625 mV |
| ± 78.125 mV | |
| 0 to 156.25 mV | |
| ± 156.25 mV | |
| 0 to 1.25 V | |

NOTE: When using this module you must also use CLICK programming software and PLC firmware version V1.40 or later.



If there are any unused channels, make sure to select the correct number of channels that you actually use in the C0-04THM Setting window.

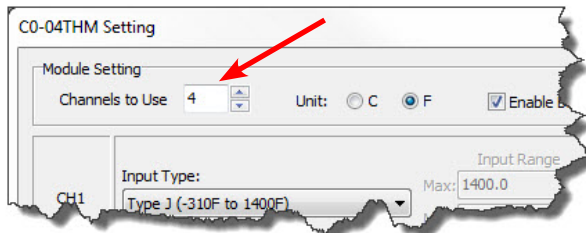

C0-04THM – 4-Channel Thermocouple Input Module (continued)

| Input Specifications (continued) | |
|---------------------------------------|---|
| Cold Junction Compensation | Automatic |
| Thermocouple Linearization | Automatic |
| Accuracy vs. Temperature | ±25 ppm per °C maximum |
| Linearity Error | ±2°C maximum, ±1°C typical, monotonic with no missing codes |
| Maximum Inaccuracy | ±3°C maximum (excluding thermocouple error) |
| Maximum Voltage Input Offset Error | 0.05% at 0° to 55° C (32° to 131° F), typical 0.04% at 25° C (77° F) |
| Maximum Voltage Input Gain Error | 0.06% at 25°C (77°F) |
| Maximum Voltage Input Linearity Error | 0.05% at 0° to 55°C (32° to 131°F), typical 0.03% at 25°C (77°F) |
| Maximum Voltage Input Inaccuracy | 0.1% at 0° to 55°C (32° to 131°F), typical 0.04% at 25°C (77°F) |
| Warm Up Time | 30 minutes for ±1°C repeatability |
| Single Channel Update Rate | 400ms |
| All Channel Update Rate | Single Channel Update Rate times the number of enabled channels on the module |
| Open Circuit Detection Time | Burn Out flag set and zero scale reading within 3 seconds |
| Conversion Method | Sigma - Delta |

Not Compatible with ZIPLink Pre-Wired PLC Connection Cables and Modules.



NOTE: When this module is used in a CLICK PLC system, it takes up to 11 seconds for initialization after power-up. During this time period, the RUN LED on the PLC module blinks to indicate the initialization process.

| Initialization Time | |
|-----------------------------|------------------------|
| The Number of Channels Used | With any Configuration |
| 1 | 5 sec |
| 2 | 7 sec |
| 3 | 9 sec |
| 4 | 11 sec |



NOTE: With grounded thermocouples, take precautions to prevent having a voltage potential between thermocouple tips. A voltage less than -1.3V or greater than +3.8V between tips will skew measurements.

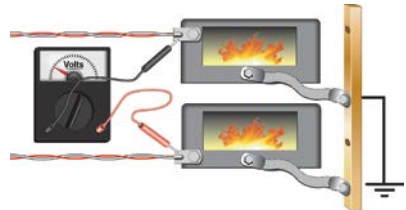

C0-04DA-1 – 4-Channel Analog Current Output Module

4-channel analog current sourcing output module, 12-bit resolution, range: 4–20 mA. External 24VDC power required, removable terminal block included.

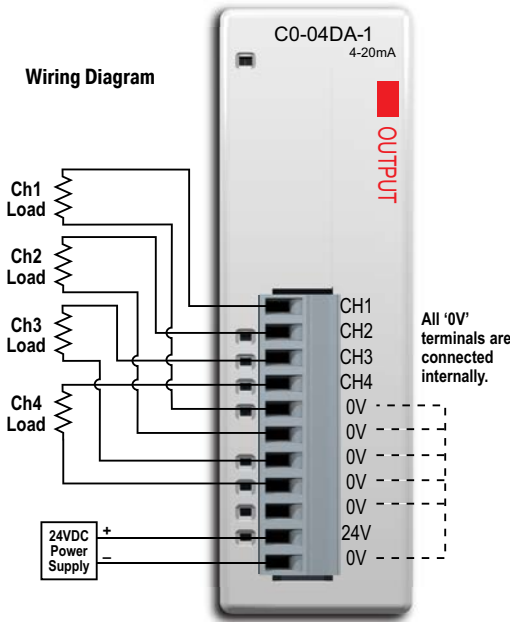

NOTE: When using this module you must also use CLICK programming software and PLC firmware version V1.40 or later.

| Output Specifications | |
|--|---|
| Outputs per Module | 4 |
| Output Range | 4–20 mA (source) |
| Resolution | 12-bit, 3.9 uA per count |
| Output Type | Current sourcing at 20mA max. |
| Output Value in Fault Mode | Less than 4mA |
| Load Impedance | 0–600Ω at 24VDC; minimum load: 0Ω 32° to 131°F (0° to 55°C) ambient temp. |
| Maximum Inductive Load | 1mH |
| Allowed Load Type | Grounded |
| Maximum Inaccuracy | ±1% of range |
| Max. Full Scale Calibration Error (Including Offset) | ±0.2% of range maximum |
| Max. Offset Calibration Error | ±0.2% of range maximum |
| Accuracy vs. Temperature | ±75 PPM/°C maximum full scale calibration change (±0.005% of range/°C) |
| Max. Crosstalk at DC, 50/60 Hz | -72 dB, 1 LSB |
| Linearity Error (End to End) | ±4 LSB max., (±0.1% of full scale) |
| Output Stability and Repeatability | ±2% LSB after 10 minute warmup period typical |
| Output Ripple | ±0.1% of full scale |
| Output Settling Time | 0.3 ms maximum, 5μs min. (full scale range) |
| All Channel Update Rate | 10ms |
| Max. Continuous Overload | Outputs open circuit protected 1800VAC applied for 1 second (100% tested) |
| Field to Logic Side Isolation | Electronically limited to 20mA or less |
| Type of Output Protection | Electronically limited to 20mA or less |
| Output Signal at Power Up and Power Down | 4mA |
| External VDC Power Required | 145mA |
| Base Power Required (24VDC) | 20mA |
| Terminal Block Replacement | AutomationDirect p/n C0-8TB |
| Weight | 2.9 oz (82g) |

ZL-RTB20 20-pin feed-through connector module



Z/PLink Pre-Wired PLC Connection Cables and Modules for CLICK PLC

11-pin connector cable
 ZL-C0-CBL11 (0.5 m length)
 ZL-C0-CBL11-1 (1.0 m length)
 ZL-C0-CBL11-2 (2.0 m length)



C0-04DA-2 – 4-Channel Analog Voltage Output Module

4-channel analog voltage output module, 12-bit resolution, range: 0–10 V. External 24VDC power required, removable terminal block included.

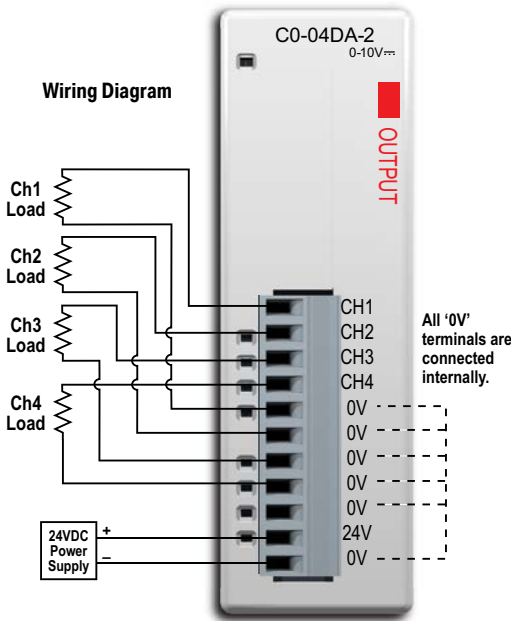

NOTE: When using this module you must also use CLICK programming software and PLC firmware version V1.40 or later.

ZIPLink Pre-Wired PLC Connection Cables and Modules for CLICK PLC

11-pin connector cable
 ZL-C0-CBL11 (0.5 m length)
 ZL-C0-CBL11-1 (1.0 m length)
 ZL-C0-CBL11-2 (2.0 m length)



ZL-RTB20 20-pin feed-through connector module



| Output Specifications | |
|--|--|
| Outputs per Module | 4 |
| Output Range | 0–10 V |
| Resolution | 12-bit, 2.44 mV per count |
| Output Type | Voltage sourcing at 10mA max. (One common) |
| Output Value in Program Mode | Determined by PLC |
| Output Value in Fault Mode | 0 V |
| Output Impedance | 0.2 Ω typical |
| Load Impedance | >1000Ω |
| Maximum Capacitive Load | 0.01 μF maximum |
| Allowed Load Type | Grounded |
| Maximum Inaccuracy | 0.5% of range |
| Max. Full Scale Calibration Error (Not including Offset) | ±0.2% of range maximum voltage |
| Max. Offset Calibration Error | ±0.2% of range maximum |
| Accuracy vs. Temperature | ±75 PPM/°C maximum full scale calibration change (±0.0025% of range/°C) |
| Max. Crosstalk at DC, 50/60 Hz | -72 dB, 1 LSB |
| Linearity Error (End to End) | ±4 LSB max., (±0.1% of full scale); monotonic with no missing codes |
| Output Stability and Repeatability | ±2% LSB after 10 minute warmup period typical |
| Output Ripple | 0.1% of full scale |
| Output Settling Time | 0.3 ms maximum, 5 μs minimum (full scale range) |
| All Channel Update Rate | 10ms |
| Max. Continuous Overload | Outputs current limited to 40mA typical; continuous overloads on multiple outputs can damage module. |
| Field to Logic Side Isolation | 1800VAC applied for 1 second (100% tested) |
| Type of Output Protection | 0.1 μF transient suppressor |
| Output Signal at Power Up and Power Down | 0 V |
| External 24VDC Power Required | 85mA |
| Base Power Required (24VDC) | 20mA |
| Terminal Block Replacement | AutomationDirect p/n C0-8TB |
| Weight | 2.9 oz (82g) |

C0-4AD2DA-1 – 4-Channel Analog Current Input and 2-Channel Analog Current Output Module

4-channel analog current sinking input (13-bit resolution) and 2-channel analog current sourcing output (12-bit resolution) module, range: 0–20 mA (inputs), 4–20 mA (outputs). External 24VDC power required, removable terminal block included.

Wiring Diagram

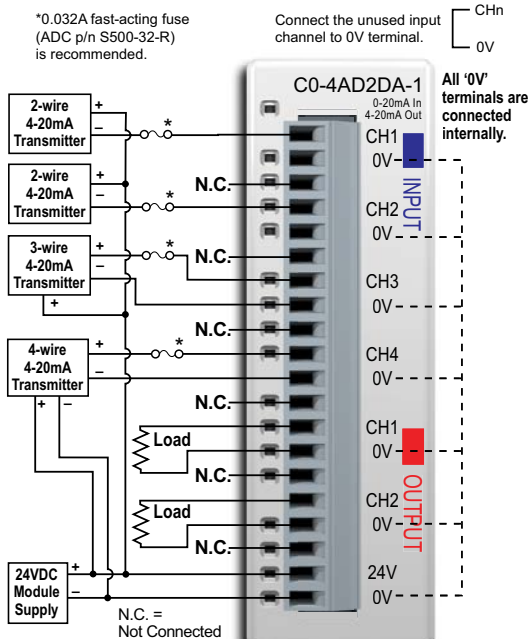

NOTE: When using this module you must also use *CLICK* programming software and PLC firmware version V1.40 or later.

ZILink Pre-Wired PLC Connection Cables and Modules for CLICK PLC

- 20-pin connector cable ZL-C0-CBL20 (0.5 m length)
- ZL-C0-CBL20-1 (1.0 m length)
- ZL-C0-CBL20-2 (2.0 m length)

ZL-RTB20 20-pin feed-through connector module



| General Specifications | |
|-------------------------------|---|
| Field to Logic Side Isolation | 1800VAC for 1 sec. |
| External 24VDC Power Required | 75mA |
| Bus Power Required (24VDC) | 25mA |
| Recommended Fuse (External) | AutomationDirect p/n S500-32-R (0.032 A fuse) |
| Terminal Block Replacement | AutomationDirect p/n C0-16TB |
| Weight | 3.1 oz (86g) |

| Input Specifications | |
|---|--|
| Inputs per Module | 4 |
| Input Range | 0-20 mA (sink) |
| Resolution | 13-bit, 2.44 uA per count |
| Input Type | Single ended (one common) |
| Maximum Continuous Overload | ±44 mA |
| Input Impedance | 124Ω, 0.5 W current input |
| Filter Characteristics | Low pass, -3 dB at 400 Hz |
| PLC Data Format | 13-bit unsigned Integer, range is 0-8191 |
| Sample Duration Time | 5 ms |
| All Channel Update Rate | 20 ms (input plus output maximum time) |
| Open Circuit Detection Time | Zero reading within 20 ms |
| Conversion Method | Successive approximation |
| Accuracy vs. Temperature | ±75 PPM/°C maximum |
| Maximum Inaccuracy | 0.5% of range (including temperature changes) ±3 count maximum, monotonic with no missing codes |
| Linearity Error (End to End) | |
| Input Stability and Repeatability | ±2 count maximum |
| Full Scale Calibration Error (Including Offset) | ±8 count maximum |
| Offset Calibration Error | ±8 count maximum |
| Maximum Crosstalk at DC, 50/60 Hz | ±2 count maximum |

C0-4AD2DA-1 – 4-Channel Analog Current Input and 2-Channel Analog Current Output Module (continued)

| Output Specifications | |
|---|---|
| Outputs per Module | 2 |
| Output Range | 4–20 mA (source) |
| Resolution | 12-bit, 3.9 uA per count |
| Output Type | Current sourcing at 20mA max. (One common) |
| PLC Data Format | 12-bit unsigned integer, 0–4095 counts |
| Output Value in Fault Mode | Less than 4mA |
| Load Impedance | 0–600 Ω at 24VDC; minimum load: 0 Ω 32° to 113°F (0° to 45°C); 125 Ω 113° to 131°F (45° to 55°C) ambient temp. |
| Maximum Inductive Load | 1mH |
| Allowed Load Type | Grounded |
| Maximum Inaccuracy | ±1% of range |
| Max. Full Scale Calibration Error (Including Offset) | ±0.2% of range maximum |
| Max. Offset Calibration Error | ±0.2% of range maximum |
| Accuracy vs. Temperature | ±50 PPM/°C maximum full scale calibration change (±0.005% of range/°C) |
| Max. Crosstalk at DC, 50/60 Hz | -72 dB, 1 LSB |
| Linearity Error (End to End) | ±4 LSB maximum, (±0.1% of full scale), monotonic with no missing codes |
| Output Stability and Repeatability | ±2% LSB after 10 minute warmup period typical |
| Output Ripple | ±0.1% of full scale |
| Output Settling Time | 0.2 ms maximum, 5 μ s min. (full scale range) |
| All Channel Update Rate | 20ms |
| Max. Continuous Overload | Outputs open circuit protected |
| Type of Output Protection | Electronically limited to 20mA or less |
| Output Signal at Power Up or Power Down | 4mA |

C0-4AD2DA-2 – 4-Channel Analog Voltage Input and 2-Channel Analog Voltage Output Module

4-channel analog voltage input (13-bit resolution) and 2-channel analog voltage output (12-bit resolution) module, range: 0-10V. External 24VDC power required, removable terminal block included.

Wiring Diagram

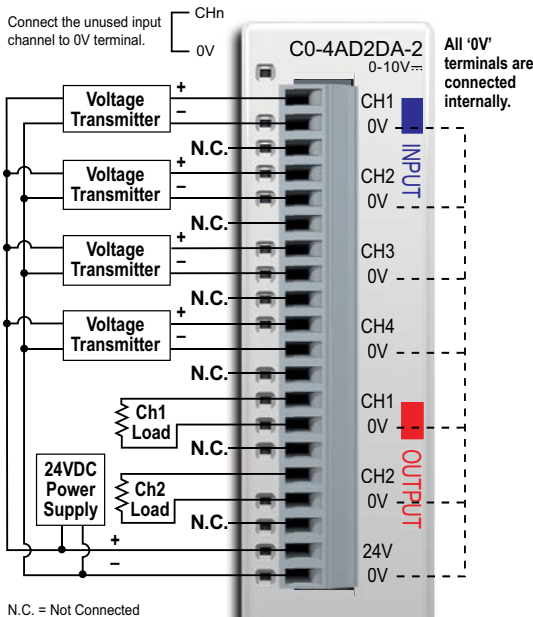

NOTE: When using this module you must also use CLICK programming software and PLC firmware version V1.40 or later.

ZIPLink Pre-Wired PLC Connection Cables and Modules for CLICK PLC

- 20-pin connector cable
- ZL-C0-CBL20 (0.5 m length)
- ZL-C0-CBL20-1 (1.0 m length)
- ZL-C0-CBL20-2 (2.0 m length)



| General Specifications | |
|-------------------------------|------------------------------|
| Field to Logic Side Isolation | 1800VAC for 1 sec. |
| External 24VDC Power Required | 65mA |
| Base Power Required (24VDC) | 20mA |
| Terminal Block Replacement | AutomationDirect p/n C0-16TB |
| Weight | 3.1 oz (86g) |

| Input Specifications | |
|---|---|
| Inputs per Module | 4 |
| Input Range | 0-10 V |
| Resolution | 13-bit, 1.22 mV per count |
| Input Type | Single ended (one common) |
| Maximum Continuous Overload | ±100VDC |
| Input Impedance | >150kΩ |
| Filter Characteristics | Low pass, -3dB at 500Hz |
| Sample Duration Time | 5ms |
| All Channel Update Rate | 20ms |
| Open Circuit Detection Time | Zero reading within 100ms |
| Conversion Method | Successive approximation |
| Accuracy vs. Temperature | ±75 PPM/°C maximum |
| Maximum Inaccuracy | 0.5% of range (including temperature changes) |
| Linearity Error (End to End) | ±3 count maximum, monotonic with no missing codes |
| Input Stability and Repeatability | ±2 count maximum |
| Full Scale Calibration Error (including Offset) | ±8 count maximum |
| Offset Calibration Error | ±8 count maximum |
| Maximum Crosstalk at DC, 50/60 Hz | ±2 count maximum |



ZL-RTB20 20-pin feed-through connector module

C0-4AD2DA-2 – 4-Channel Analog Voltage Input and 2-Channel Analog Voltage Output Module (continued)

| Output Specifications | |
|---|--|
| Outputs per Module | 2 |
| Output Range | 0–10 V |
| Resolution | 12-bit, 2.44 mV per count |
| Output Type | Voltage sourcing at 10mA max. (One common) |
| Output Value in Program Mode | Determined by PLC |
| Output Value in Fault Mode | 0V |
| Output Impedance | 0.2 Ω typical |
| Load Impedance | >1000 Ω |
| Maximum Capacitive Load | 0.01 μ F maximum |
| Allowed Load Type | Grounded |
| Maximum Inaccuracy | 1% of range |
| Max. Full Scale Calibration Error (Not including Offset) | \pm 0.2% of range maximum voltage |
| Max. Offset Calibration Error | \pm 0.2% of range maximum |
| Accuracy vs. Temperature | \pm 75 PPM/ $^{\circ}$ C maximum full scale calibration change (\pm 0.0025% of range/ $^{\circ}$ C) |
| Max. Crosstalk at DC, 50/60 Hz | -72dB, 1 LSB |
| Linearity Error (End to End) | \pm 4 LSB maximum, (\pm 0.1% of full scale); monotonic with no missing codes |
| Output Stability and Repeatability | \pm 2% LSB after 10 minute warmup period typical |
| Output Ripple | 0.5% of full scale |
| Output Settling Time | 0.3 ms maximum, 5 μ s minimum (full scale range) |
| All Channel Update Rate | 20ms |
| Max. Continuous Overload | Outputs current limited to 40mA typical; continuous overloads on multiple outputs can damage module. |
| Type of Output Protection | 0.1 μ F transient suppressor |
| Output Signal at Power Up or Power Down | 0V |

Power Supply Specifications

C0-00AC Power Supply

Limited auxiliary AC power supply allows you to power the CLICK PLC with 100-240 VAC supply power. The 0.5 A DC power supply is capable of controlling the PLC plus a limited configuration based on the power budget of each I/O module. The C0-00AC is a low-cost solution for applications requiring only minimal I/O and power consumption. This power supply will not support a fully-populated CLICK PLC system with all possible I/O module combinations.



C0-00AC Power Supply Specification

| | |
|--------------------------------|---------------------------------|
| Input Voltage Range | 85-264 VAC |
| Input Frequency | 47-63 Hz. |
| Input Current (typical) | 0.3 A @ 100 VAC, 0.2 A @ 200VAC |
| Inrush Current | 30A |
| Output Voltage Range | 23-25 VDC |
| Output Current | 0.5 A |
| Over Current Protection | @ 0.65 A (automatic recovery) |
| Weight | 5.3 oz (150g) |

C0-01AC Power Supply

No-limit auxiliary AC power supply allows you to power the CLICK PLC with 100-240 VAC supply power. The 1.3 A DC power supply is capable of supporting a fully-populated CLICK PLC system with all possible I/O module combinations with no concerns of exceeding the power budget.



C0-01AC Power Supply Specification

| | |
|--------------------------------|--------------------------------|
| Input Voltage Range | 85-264 VAC |
| Input Frequency | 47-63 Hz. |
| Input Current (typical) | 0.9 A @ 100VAC, 0.6 A @ 200VAC |
| Inrush Current | 30A |
| Output Voltage Range | 23-25 VDC |
| Output Current | 1.3 A |
| Over Current Protection | @ 1.6 A (automatic recovery) |
| Weight | 6.0 oz (170g) |

PSP24-DC12-1 DC-DC Converter

With this DC-DC converter you can operate the CLICK PLC with 12VDC input power.



PSP24-DC12-1 DC-DC Converter Specifications

| | |
|---------------------------------|---------------------------------|
| Input Voltage Range | 9.5-18 VDC |
| Input Power (no load) | 1.0 W max. |
| Startup Voltage | 8.4 VDC |
| Undervoltage Shutdown | 7.6 VDC |
| Output Voltage Range | 24-28 VDC (adjustable) |
| Output Current | 1.0 A |
| Short Circuit Protection | Current limited at 110% typical |
| Weight | 7.5 oz (213g) |

Accessories

C0-USER-M – CLICK PLC Hardware Users Manual



Manual covers all CLICK PLC & I/O Module installation & wiring, specifications, error codes & trouble shooting guide. Sold separately from hardware.

The CLICK PLC Hardware User Manual can be downloaded free at the AutomationDirect Web site or purchased from the AutomationDirect online Web store, www.automationdirect.com

C0-PGMSW – CLICK PLC Programming Software USB



CLICK PLC programming software Ladder Logic Editor for Windows PCs, includes the manual as a pdf file. Free download available from AutomationDirect online Web store: www.automationdirect.com. Alternatively the programming software USB may be purchased and shipped from the AutomationDirect online Web store: www.automationdirect.com

EA-MG-PGM-CBL – PC to Panel Programming Cable Assembly for C-more Micro-Graphic Panels and/or PC to CLICK PLCs.



NOTE: If your PC has a USB port but does not have a serial port, you must use programming cable EA-MG-PGM-CBL.

D2-DSCBL – PC Programming Cable for CLICK and *Direct*LOGIC PLCs



12ft (3.66 m) RS232 shielded PC programming cable for CLICK, DL05, DL06, DL105, DL205, D3-350, and D4-450 CPUs. 9-pin D-shell female connector to an RJ12 6P6C connector.

Cat5e – PC Programming Ethernet Cable for CLICK PLCs



3ft–50ft Cat5e STP Ethernet Patch Cable for PC programming of CLICK PLCs; RJ45 connector. Straight or Cross-over cable can be used.

Accessories (cont'd)

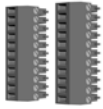

C0-8TB – Spare 8 Point I/O Terminal Block

Replacement terminal block for the 8 point I/O modules. Sold in packs of 2.

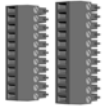

C0-8TB-1 – Spare 8 Point I/O Terminal Block

Replacement terminal block for the 8 point relay I/O modules. Sold in packs of 2.

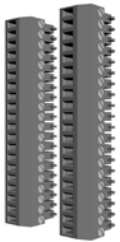

C0-16TB – Spare 16 Point I/O Terminal Block

Replacement terminal block for the 16 point I/O modules & PLC built-in I/O. Sold in packs of 2.



C0-3TB - Spare 3-Pole Terminal Block

Replacement 3-pole terminal block for the 3-wire, RS485 communications port on the CLICK Standard and Analog PLCs. Sold in packs of 2.

C0-4TB – Spare 24VDC Power Terminal Block

Replacement terminal block for the 24VDC supply power to the PLC. Sold in packs of 2.



D2-BAT-1 – Battery

Replacement battery for Standard, Analog, and Ethernet PLC units.

ZIPLink Wiring Systems

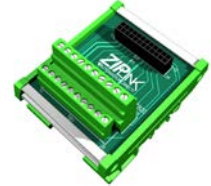

C-more and C-more Micro-Graphic Operator Interfaces



DN-WS – Wire Stripper



TW-SD-MSL-2 – Insulated Slotted Screwdriver 0.4 x 2.5 x 80 mm



DN-EB35MN – DINnectors End Bracket

