

F2-8AD4DA-2 8-CH. IN / 4-CH. OUT CURRENT VOLTAGE COMBINATION



In This Chapter...

Module Specifications	16-2
Connecting the Field Wiring	16-6
Module Operation	16-8
Special V-Memory Locations	16-12
Writing the Control Program.....	16-16

Module Specifications

The F2-8AD4DA-2 Analog Voltage Input/Output module provides several hardware features:

- Analog inputs and outputs are optically isolated from the PLC logic.
- The module has a removable terminal block so the module can be easily removed or changed without disconnecting the wiring.
- All input and output channels are updated in one scan.
- On-board active analog filtering, two CISC microcontrollers and CPLD provide digital signal processing to maintain precision analog measurements in noisy environments.
- Low-power CMOS design requires only 80mA from an external 18–26.4 VDC power supply.
- Input resolution is independently adjustable for each channel. Users may select 12-bit, 14-bit or 16-bit.
- Output resolution is 16-bit.
- Each input can be independently configured to return the present value, or to track and hold the maximum or minimum value.
- No jumper settings.

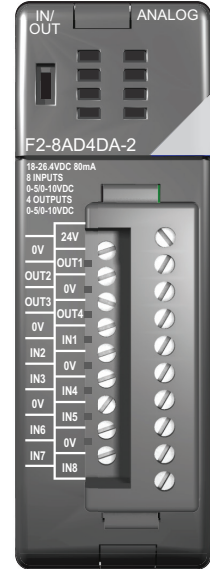

F2-8AD4DA-2

F2-8AD4DA-2 Hardware and Firmware Requirements

The F2-8AD4DA-2 Analog Voltage Input/Output Module requires one of the following components as a CPU or controller.

Hardware and Firmware Requirements		
Base Type	CPU/Controller	Firmware Version
Local	D2-250-1	4.40 or later
	D2-260	2.20 or later
	D2-262	1.0 TBD
Expansion	D2-CM	1.30 or later
Remote I/O	H2-EBC(-F)	2.1.441 or later
	H2-EBC100	4.0.457 or later

The following tables provide the specifications for the F2-8AD4DA-2 Analog Voltage Input/Output Module. Review these specifications to be certain that it will meet the requirements of your application.

Input Specifications	
Number of Input Channels	8, single ended (one common)
Input Range	0–5 V, 0–10 V
Input Resolution / Value of LSB	12, 14, or 16-bit; selectable 12-bit, 0–5 V = 1.22 mV 12-bit, 0–10 V = 2.44 mV 14-bit, 0–5 V = 305µV 14-bit, 0–10 V = 610µV 16-bit, 0–5 V = 76µV 16-bit, 0–10 V = 152µV
Input Impedance	1MΩ, ±5%
Maximum Continuous Overload	±100V
Filter Characteristics	Active low pass; -3 dB @ 80Hz
PLC Input Update Rate	8 channels per scan (max. with pointers; local base)
Sample Duration Time (note)	2ms @ 12-bit; 5.52ms @ 14-bit; 23ms @ 16-bit
Conversion Time (note)	12-bit = 1.5 ms per channel 14-bit = 6ms per channel 16-bit = 25ms per channel
Conversion Method	Over sampling successive approximation
Accuracy vs. temperature	25ppm / °C maximum
Input Stability and Repeatability	±0.03% of range (after 30 minute warm-up)
Input Inaccuracy	0.1% of range maximum
Linearity Error (end to end)	12-bit = ±2 counts max. (±0.06% of range) 14-bit = ±10 counts max. (±0.06% of range) 16-bit = ±40 counts max. (±0.06% of range) Monotonic with no missing codes
Full Scale Calibration Error (not including offset error)	±0.07% of range maximum
Offset Calibration Error	±0.025% of range maximum
Common Mode Rejection	-90dB min. @ DC; -150dB min. @ 50/60Hz
Crosstalk	±0.025% of range max. @ DC, 50/60Hz



NOTE: The values listed for Sample Duration Time and Conversion Time are for a single channel, and do not include PLC scan times.

Output Specifications	
Number of Output Channels	4
Output Range	0–5 V, 0–10 V
Output Resolution	16-bit
Output Type	Voltage sourcing / sinking at 10mA max.
Output Signal at Power-up & Power-down	0V
Output Impedance	0.2 Ω typical
External Load Resistance	>1000 Ω
Maximum Capacitive Load	0.1 μ F
Allowed Load Type	Grounded
Max. Continuous Output Overload	Limited to 15mA typical
Type of Output Protection	15VDC Peak Output Voltage (clamped by transient voltage suppressor)
PLC Output All Channel Update Time	4ms (local base)
Output Settling Time	0.5 ms max.; 5 μ s min. (full scale change)
Output Ripple	0.005% of full scale
Accuracy vs. Temperature	\pm 25 ppm/ $^{\circ}$ C max. full scale calibration change (\pm 0.0025% of range / $^{\circ}$ C)
Output Stability and Repeatability	\pm 1 LSB after 10 minute warm-up typical
Output Inaccuracy	0.1% of range maximum
Linearity Error (end to end)	\pm 33 counts max. (\pm 0.05% of full scale) Monotonic with no missing codes
Full Scale Calibration Error (not including offset error)	\pm 0.07% of range maximum
Offset Calibration Error	\pm 0.03% of range maximum
Crosstalk at DC, 50/60Hz	-70dB or 0.025% of full scale



NOTE: One count in the specifications table is equal to one least significant bit of analog data value (1 in 65536)

General Module Specifications	
Digital Input and Output Points Required	32 point (X) Inputs 32 point (Y) Outputs
Power Budget Requirement	35mA @ 5VDC (supplied by the base)
External Power Supply Requirement	18–26.4 VDC, 80mA maximum
Field Side to Logic Side Isolation	1800VAC applied for 1 second (100% tested)
Insulation Resistance	>10MΩ @ 500VDC
Operating Temperature	0–60°C (32–140°F); IEC60068-2-14
Storage Temperature	–20–70°C (- 4–158°F); IEC60068-2-1, -2-2, -2-14
Relative Humidity	5–95% (non-condensing); IEC60068-2-30
Environmental Air	No corrosive gases permitted; EN61131-2 pollution degree 1
Vibration	MIL STD 810C 514.2; IEC60068-2-6
Shock	MIL STD 810C 516.2; IEC60068-2-27
Noise Immunity	NEMA ICS3-304; IEC61000-4-2, -4-3, -4-4
Emissions	EN61000-6-4 (conducted and radiated RF emissions)
Module Location	Any non-CPU slot in local, expansion, or Ethernet remote base of DL205 system with D2-250-1, D2-260 or D2-262 CPU
Field Wiring	19 point removable terminal block included. Optional remote wiring using ZL-CM20 remote feed-through terminal block module and ZL-2CBL2# cable.
Agency Approvals	UL508; UL6079-15 Zone 2; CE (EN61131-1)

Module Placement and Configuration Requirements

The F2-8AD4DA-2 analog voltage input/output module requires 32 discrete input and 32 discrete output points.

The module can be installed in any non-CPU slot of D2-250-1, D2-260 or D2-262 local bases, D2-CM expansion bases, H2-EBC(100)(-F) Ethernet remote bases, H2-PBC Profibus slave bases, or H2-WPLCx-xx WinPLC bases.



NOTE: The module is NOT supported by D2-230, D2-240, or D2-250 CPUs. It is also not supported by D2-RMSM and D2-RSSS remote I/O master/slave modules.

The available power budget may also be a limiting factor. Check the user manual for the particular module of CPU and I/O base for more information regarding power budget and number of local, local expansion, or Ethernet remote I/O points.

Connecting the Field Wiring

Wiring Guidelines

Your company may have guidelines for wiring and cable installation. If so, check the guidelines before beginning the installation. Here are some general things to consider:

- Use the shortest wiring route whenever possible.
- Use shielded wiring and ground the shield at the transmitter source. Do not ground the shield at both the module and the load or source.
- Do not run the signal wiring next to large motors, high current switches, or transformers. This may cause noise problems.
- Route the wiring through an approved cable housing to minimize the risk of accidental damage. Check local and national codes to choose the correct method for your application.
- Unused inputs should be shorted together and connected to common.

User Power Supply Requirements

The F2-8AD4DA-2 module requires at least one field-side power supply. The same or separate power sources can be used for the module supply and the transmitter supply. The module requires 18-26.4 VDC (at 80mA), from the external power supply.

The DL205 AC bases have a built-in 24VDC power supply that provide up to 300mA of current. This can be used instead of a separate supply. Check the power budget to be safe.

It is desirable in some situations to power the transmitters separately in a location remote from the PLC. This will work as long as the transmitter supply meets the voltage and current requirements, and that the transmitter and the module power supply negative (-) side are connected together.



WARNING: If the 24VDC base power is used, be sure to calculate the power budget. Exceeding the power budget can cause unpredictable system operation that can lead to a risk of personal injury or equipment damage.

The DL205 base has a switching type power supply. As a result of switching noise, ± 3 –5 counts of instability may be noticed in the analog input data if the base power supply is used. If this is unacceptable, try one of the following:

- Use a separate linear power supply.
- Connect the 24VDC common to the frame ground, which is the screw terminal marked “G” on the base.

When using these methods, the input stability is rated at $\pm 0.03\%$ of range.

Wiring Diagram

The F2-8AD4DA-2 module has a removable connector to simplify wiring. Simply squeeze the top and bottom retaining clips and gently pull the connector from the module. Use the following diagram to connect the field wiring.

The diagram shows one power supply for both the module and the I/O signal loops. If a separate module and transmitter supplies are to be used, connect the power supply 0V commons together.

The four wire transmitter connected to input channel 8 is powered by an independent power source. In this case, the transmitter is treated as a 2-wire transmitter.

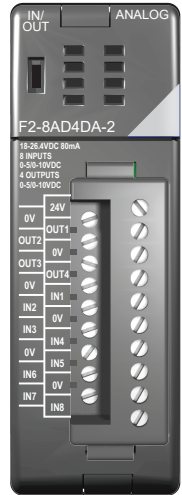
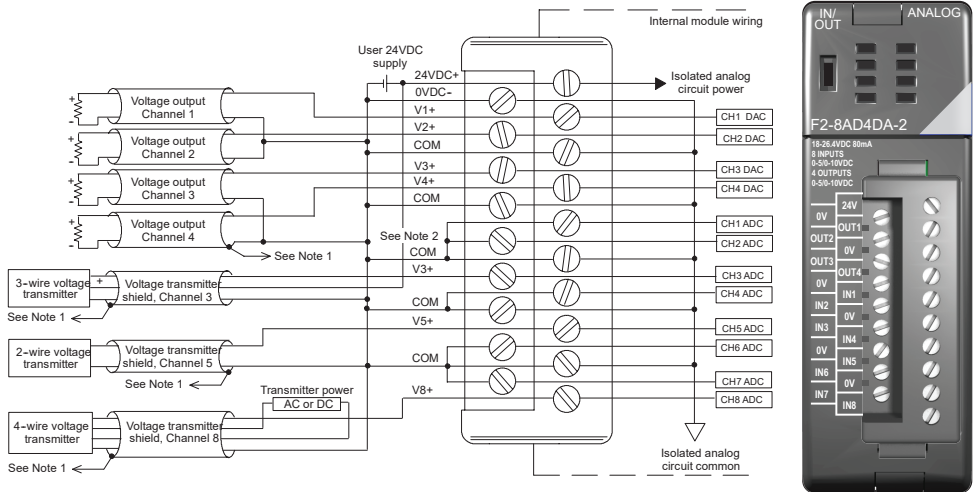

NOTE 1: Connect shields to the 0V of the module; do not connect both ends of the shield.

NOTE 2: Short unused inputs together and connect them to common.

Module Operation

Input Channel Scanning Sequence (Pointer Method)

If the F2-8AD4DA-2 module is installed in a local (CPU) base, the input data for all eight channels can be obtained in one scan. However, only one channel of input data can be obtained if the module is installed in an expansion, remote I/O, or Profibus slave base.

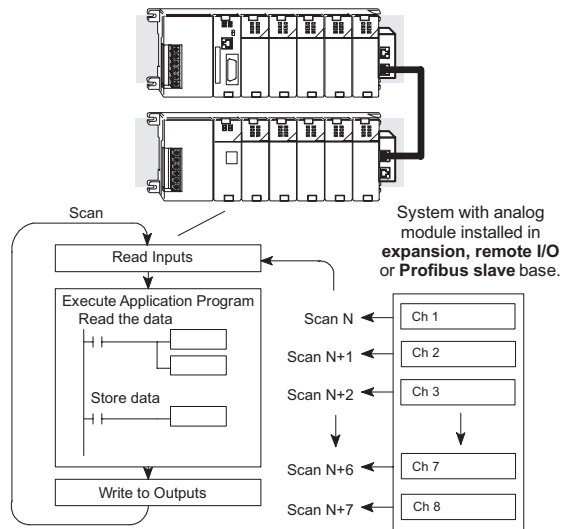
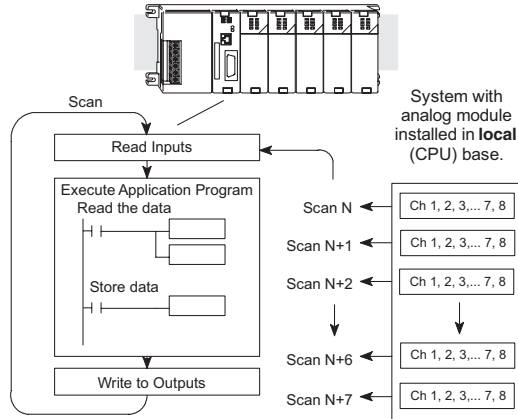

Output Channel Update Sequence (Pointer Method)

If the F2-8AD4DA-2 is installed in a local (CPU) base, all four output channels can be updated on every scan. However, only one channel can be updated per scan if the module is installed in an expansion, remote I/O, or Profibus slave base. The timing is synchronized with the timing of reading the input channels, so each output channel can be updated every eight scans.

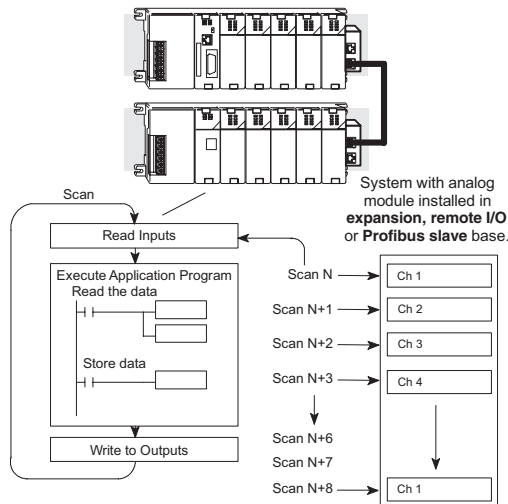
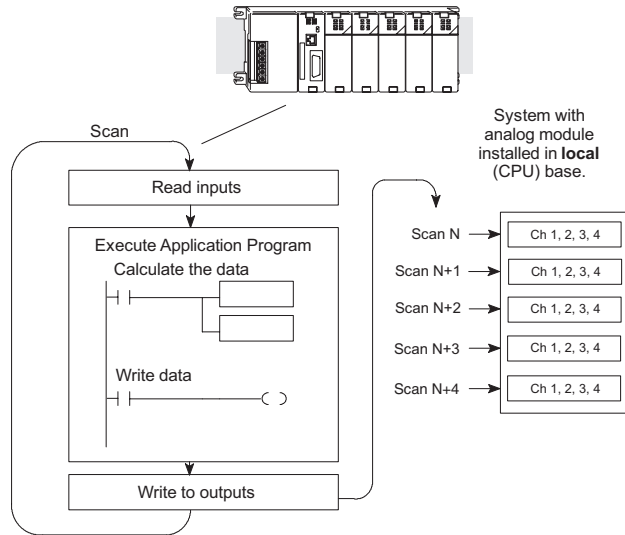

Understanding the I/O Assignments

Remember that the F2-8AD4DA-2 module appears to the CPU as a 32-point discrete input module and a 32-point discrete output module. These points can be used to obtain:

- An indication of which channel is active,
- The digital representation of the analog signal,
- Module diagnostic information,
- Settings for resolution, range, and track and hold.

These bits may never have to be used, but it may be an aid to help understand the data format. Since all I/O points are automatically mapped into V-memory, the location of the data words that will be assigned to the module can simply be determined.

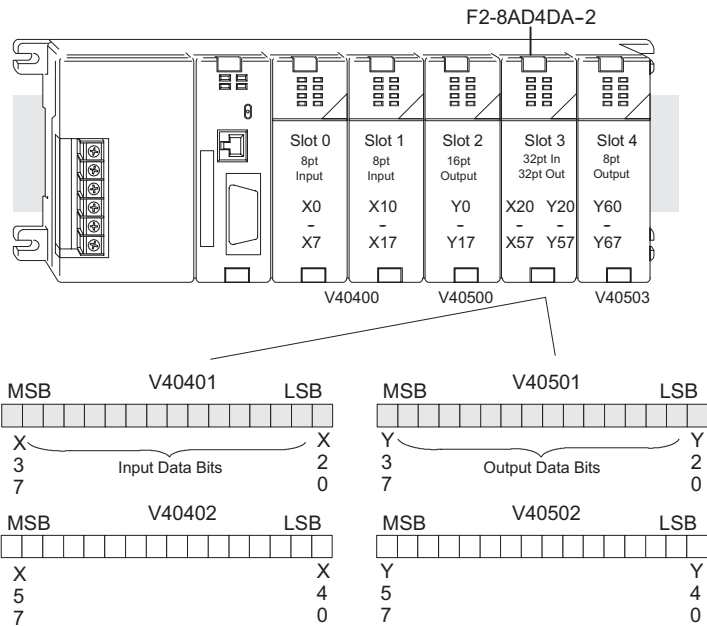

The individual bits in these data word locations represent specific information about the analog signal. (The specific memory locations may vary, depending upon the slot where the F2-8AD4DA-2 module is located.)

Input Data Bits

Depending upon the resolution selected, up to 16-bits of the first input word represent the analog data in binary format.

Bit	Value	Bit	Value
0	1	8	256
1	2	9	512
2	4	10	1024
3	8	11	2048
4	16	12	4096
5	32	13	8192
6	64	14	16384
7	128	15	32768

The input word is not usable by the programmer.

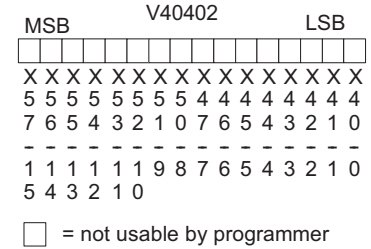
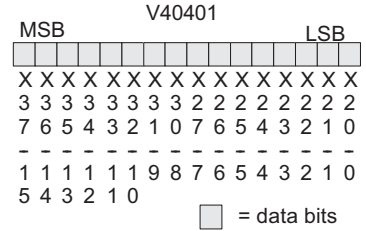

Output Data Bits

All 16-bits of the first output word represent the analog data in binary format.

Bit	Value	Bit	Value
0	1	8	256
1	2	9	512
2	4	10	1024
3	8	11	2048
4	16	12	4096
5	32	13	8192
6	64	14	16384
7	128	15	32768

The second output word is not usable by the programmer.

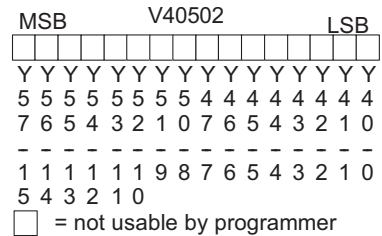
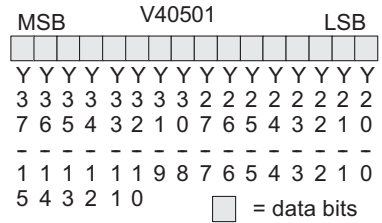

Special V-Memory Locations

The D2-250-1, D2-260 and D2-262 CPUs have special V-memory locations assigned to each base slot that greatly simplifies the programming requirements. These V-memory locations specify:

- The number of input and output channels to scan
- The storage locations for the input and output data
- The resolution for the inputs
- The range selections for the inputs and outputs
- The track and hold selections for the inputs

Module Configuration Registers

The following tables show the special V-memory used by the CPUs for the CPU base and local expansion base I/O slots. Slot 0 is the module slot next to the CPU or D2-CM module. Slot 1 is the module slot two places from the CPU or D2-CM, and so on. The CPU needs to examine the pointer values at these locations only after a mode transition.

CPU Base: Analog In/Out Module Slot-Dependent V-memory Locations								
Slot	0	1	2	3	4	5	6	7
No. of I/O Channels Enabled & Format	V7660	V7661	V7662	V7663	V7664	V7665	V7666	V7667
Input Pointer	V7670	V7671	V7672	V7673	V7674	V7675	V7676	V7677
Output Pointer	V7700	V7701	V7702	V7703	V7704	V7705	V7706	V7707
Input Resolutions	V36400	V36401	V36402	V36403	V36404	V36405	V36406	V36407
I/O Range Selection	V36410	V36411	V36412	V36413	V36414	V36415	V36416	V36417
Input Track & Hold	V36420	V36421	V36422	V36423	V36424	V36425	V36426	V36427

Expansion Base D2-CM #1: Analog In/Out Module Slot-Dependent V-memory Locations								
Slot	0	1	2	3	4	5	6	7
No. of I/O Channels Enabled & Format	V36000	V36001	V36002	V36003	V36004	V36005	V36006	V36007
Input Pointer	V36010	V36011	V36012	V36013	V36014	V36015	V36016	V36017
Output Pointer	V36020	V36021	V36022	V36023	V36024	V36025	V36026	V36027
Input Resolutions	V36030	V36031	V36032	V36033	V36034	V36035	V36036	V36037
I/O Range Selection	V36040	V36041	V36042	V36043	V36044	V36045	V36046	V36047
Input Track & Hold	V36050	V36051	V36052	V36053	V36054	V36055	V36056	V36057

Expansion Base D2-CM #2: Analog In/Out Module Slot-Dependent V-memory Locations								
Slot	0	1	2	3	4	5	6	7
No. of I/O Channels Enabled & Format	V36100	V36101	V36102	V36103	V36104	V36105	V36106	V36107
Input Pointer	V36110	V36111	V36112	V36113	V36114	V36115	V36116	V36117
Output Pointer	V36120	V36121	V36122	V36123	V36124	V36125	V36126	V36127
Input Resolutions	V36130	V36131	V36132	V36133	V36134	V36135	V36136	V36137
I/O Range Selection	V36140	V36141	V36142	V36143	V36144	V36145	V36146	V36147
Input Track & Hold	V36150	V36151	V36152	V36153	V36154	V36155	V36156	V36157

Expansion Base D2-CM #3: Analog In/Out Module Slot-Dependent V-memory Locations								
Slot	0	1	2	3	4	5	6	7
No. of I/O Channels Enabled & Format	V36200	V36201	V36202	V36203	V36204	V36205	V36206	V36207
Input Pointer	V36210	V36211	V36212	V36213	V36214	V36215	V36216	V36217
Output Pointer	V36220	V36221	V36222	V36223	V36224	V36225	V36226	V36227
Input Resolutions	V36230	V36231	V36232	V36233	V36234	V36235	V36236	V36237
I/O Range Selection	V36240	V36241	V36242	V36243	V36244	V36245	V36246	V36247
Input Track & Hold	V36250	V36251	V36252	V36253	V36254	V36255	V36256	V36257

Expansion Base D2-CM #4: Analog In/Out Module Slot-Dependent V-memory Locations								
Slot	0	1	2	3	4	5	6	7
No. of I/O Channels Enabled & Format	V36300	V36301	V36302	V36303	V36304	V36305	V36306	V36307
Input Pointer	V36310	V36311	V36312	V36313	V36314	V36315	V36316	V36317
Output Pointer	V36320	V36321	V36322	V36323	V36324	V36325	V36326	V36327
Input Resolutions	V36330	V36331	V36332	V36333	V36334	V36335	V36336	V36337
I/O Range Selection	V36340	V36341	V36342	V36343	V36344	V36345	V36346	V36347
Input Track & Hold	V36350	V36351	V36352	V36353	V36354	V36355	V36356	V36357

Number of I/O Channels Enabled & Data Format

Load this V-memory location with a constant that specifies the number of enabled I/O channels and their data formats. The upper byte applies to the inputs, and the lower byte applies to the outputs. The most significant nibbles specify the data formats, and the least significant nibbles specify the number of channels enabled.

V-memory Locations for No. of I/O Channels Enabled & Format								
No. of Channels Enabled	1	2	3	4	5	6	7	8
BCD Input	K01xx	K02xx	K03xx	K04xx	K05xx	K06xx	K07xx	K08xx
Binary Input	K81xx	K82xx	K83xx	K84xx	K85xx	K86xx	K87xx	K88xx
BCD Output	Kxx01	Kxx02	Kxx03	Kxx04	n/a	n/a	n/a	n/a
Binary Output	Kxx81	Kxx82	Kxx83	Kxx84	n/a	n/a	n/a	n/a

Input Selection Resolution Bits

Each of the eight input channels can be individually disabled or configured for 12, 14, or 16-bit resolution.

V36403: (specific memory location will vary depending upon the base and slot location).

15	14	13	12	11	10	9	8	7	6	5	4	3	2	1	0
R-8H	R-8L	R-7H	R-7L	R-6H	R-6L	R-5H	R-5L	R-4H	R-4L	R-3H	R-3L	R-2H	R-2L	R-1H	R-1L

RnH = Resolution channel n High bit

RnL = Resolution channel n Low bit

Input Resolution Select	RnH	RnL
12-bit	0	0
14-bit	0	1
16-bit	1	0
Disabled	1	1

Example: Input channels 1–4 are 12-bit, channel 5 is 14-bit, and channel 6 is 16-bit, and channels 7 and 8 are disabled; V36403-F900(hex).

15	14	13	12	11	10	9	8	7	6	5	4	3	2	1	0
R-8H	R-8L	R-7H	R-7L	R-6H	R-6L	R-5H	R-5L	R-4H	R-4L	R-3H	R-3L	R-2H	R-2L	R-1H	R-1L
1	1	1	1	1	0	0	1	0	0	0	0	0	0	0	0
F				9				0				0			

Input and Output Range Selection Bits

The range of the eight input channels can be collectively set for 0–5 V or for 0–10 V. The range of the four output channels can also be collectively set for either of the same two voltage ranges.

V36413: (specific memory location will vary depending upon the base and slot location).

15	14	13	12	11	10	9	8	7	6	5	4	3	2	1	0
-	-	-	-	-	-	-	OR	-	-	-	-	-	-	-	IR

IR = Input Range

OR = Output Range

Input/Output Range	IR	OR
0–5 V	0	0
0–10 V	1	1

Example: Input channel range is 0–5 V, and output channel range is 0–10 V; V36413=100(hex).

15	14	13	12	11	10	9	8	7	6	5	4	3	2	1	0
-	-	-	-	-	-	-	OR	-	-	-	-	-	-	-	IR
0	0	0	0	0	0	0	1	0	0	0	0	0	0	0	0
0				1				0				0			

Input Track and Hold Selection Bits

The track and hold feature for each of the eight inputs can be individually configured for minimum, maximum, no hold, or reset held value. This configuration can be changed “on the fly” while the program is running.

V36423: (specific memory location will vary depending upon the base and slot location).

15	14	13	12	11	10	9	8	7	6	5	4	3	2	1	0
T-8H	T-8L	T-7H	T-7L	T-6H	T-6L	T-5H	T-5L	T-4H	T-4L	T-3H	T-3L	T-2H	T-2L	T-1H	T-1L

TnH = Track and hold channel n High bit

TnL = Track and hold channel n Low bit

Track and Hold Select	TnH	TnL	Result
No Track and Hold	0	0	returns real time input value
Track and Hold Minimum Value	0	1	maintains lowest measured value
Track and Hold Maximum Value	1	0	maintains highest measured value
Reset Track and Hold Value	1	1	resets previously held input value

Example: Input channel track and hold settings: 1-3 = none, ch 4-5 = minimum, ch 6-7 = maximum, ch 8 = reset; V36423=E940(hex).

15	14	13	12	11	10	9	8	7	6	5	4	3	2	1	0
T-8H	T-8L	T-7H	T-7L	T-6H	T-6L	T-5H	T-5L	T-4H	T-4L	T-3H	T-3L	T-2H	T-2L	T-1H	T-1L
1	1	1	0	1	0	0	1	0	1	0	0	0	0	0	0
E				9				4				0			

Writing the Control Program

Configuring the Module to Read/Write I/O (Pointer Method) for D2-250-1, D2-260 and D2-262

The example programs that follow show how to configure the special V-memory locations to read/write data from/to the I/O module. The module configuration rung needs to be read by the CPU only after a mode transition, and does not need to be read every scan. Place the configuration rung anywhere in the ladder program, or in the initial stage if stage programming instructions is being used. This is all that is required to read the input data and write the output data to/from the V-memory locations. Once the input data is in V-memory, math can be used for data calculations, compare the data against preset values, and so forth.

V2000 and V2020 are used as the beginning of the data areas in the example, but any user V-memory locations can be used. Also, these examples assume that the module is installed in slot 3 of the CPU base. The pointer V-memory locations determined by the layout of the application should be used.

Module Configuration Example 1:

Number of Channels = 8 in, 4 out,
 Data Format = binary in, BCD out,
 Input Resolution = 16-bit,
 Input/Output Range = 0–5 V in, 0–5 V out
 Input Track and Hold = none, real time value.

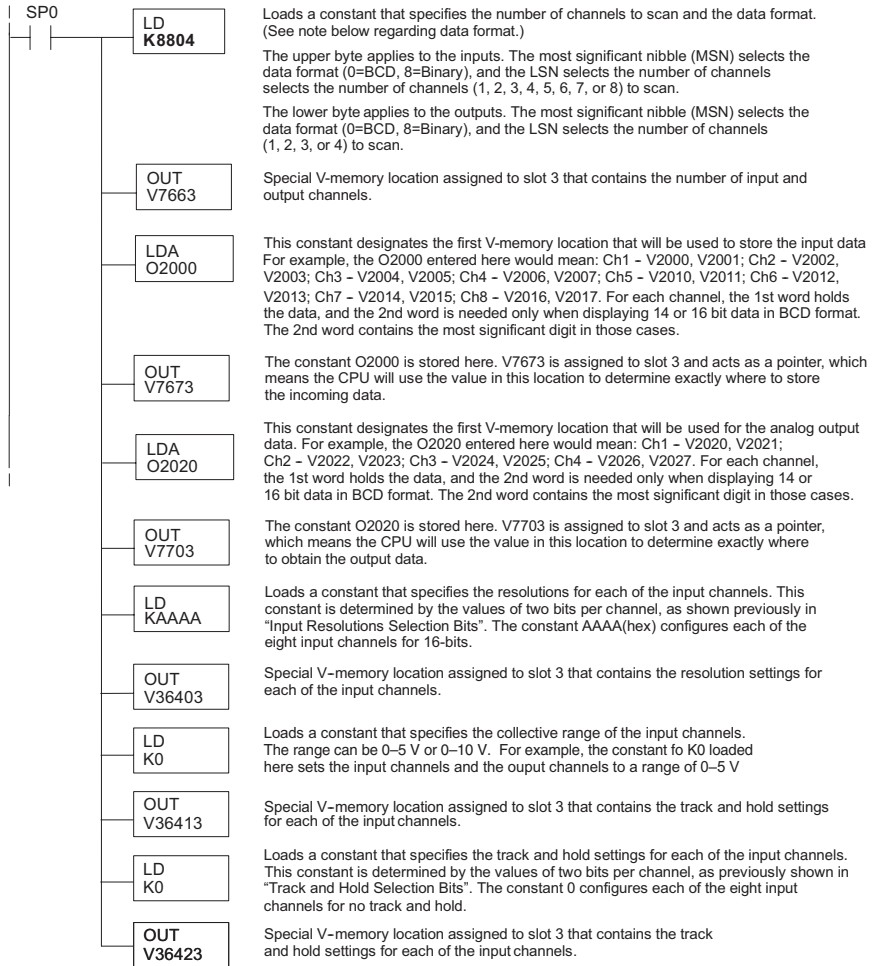

NOTE: Binary data format is recommended for 14 or 16-bit resolution input data, especially if the input data is to be used in any math instructions (DL205 User Manual, ch.5). There is only one V-memory word (16-bits) available for the actual data. Although the 12-bit resolution maximum value of 4095 can be stored in one word using either binary or BCD formats, the 14 and 16-bit resolution maximum values of 16383 and 65535 both exceed the BCD format's maximum single word capacity of 9999. Double word math would be required for 14 or 16-bit data in BCD format. Binary data format is also useful for displaying data on some operator interfaces.



Module Configuration Example 2:

Number of Channels = 4 in, 4 out,
 Data Format = binary in, BCD out,
 Input Resolution = 14-bit,
 Input/Output Range = 0–10 V in, 0–5 V out,
 Input Track and Hold = all inputs maximum value.

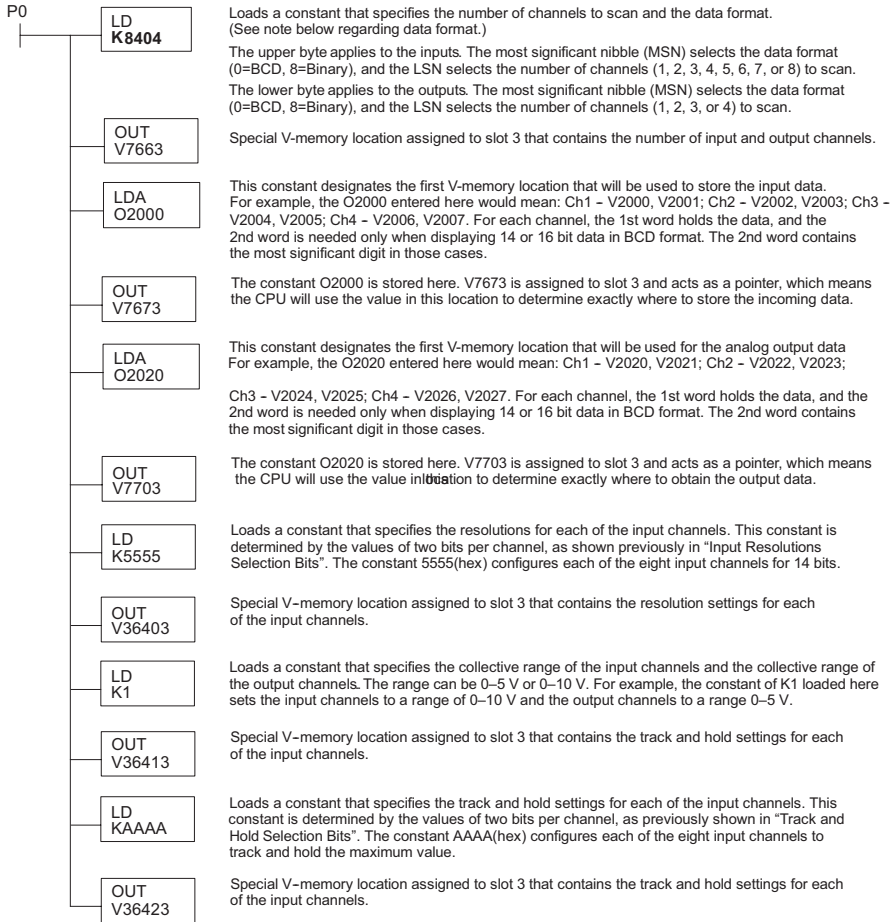

NOTE: Binary data format is recommended for 14 or 16-bit resolution input data, especially if the input data is to be used in any math instructions (DL205 User Manual, ch.5). There is only one V-memory word (16-bits) available for the actual data. Although the 12-bit resolution maximum value of 4095 can be stored in one word using either binary or BCD formats, the 14 and 16-bit resolution maximum values of 16383 and 65535 both exceed the BCD format's maximum single word capacity of 9999. Double word math would be required for 14 or 16-bit data in BCD format. Binary data format is also useful for displaying data on some operator interfaces.



Module Configuration Example 3:

Number of Channels = 4 in, 2 out,
 Data Format = BCD in, BCD out,
 Input Resolution = 12-bit,
 Input/Output Range = 0–10 V in, 0–10 V out,
 Input Track and Hold = all inputs minimum value.

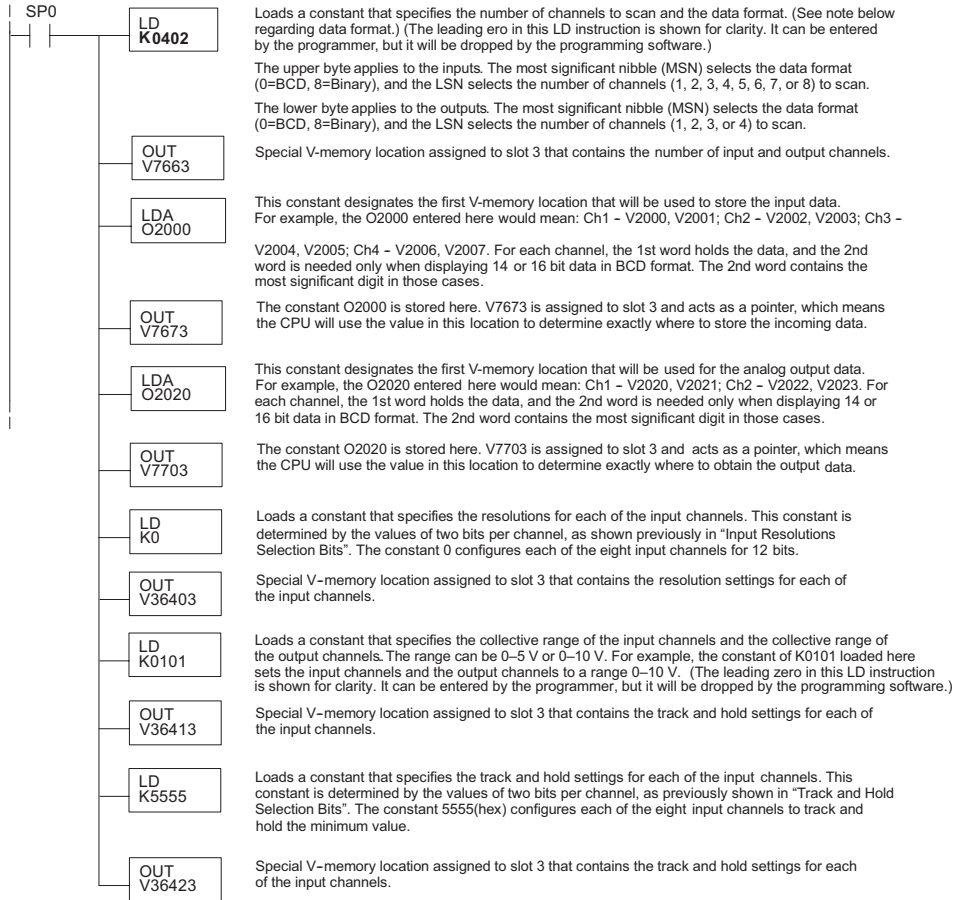

NOTE: Binary data format is recommended for 14 or 16-bit resolution input data, especially if the input data is to be used in any math instructions (DL205 User Manual, ch.5). There is only one V-memory word (16-bits) available for the actual data. Although the 12-bit resolution maximum value of 4095 can be stored in one word using either binary or BCD formats, the 14 and 16-bit resolution maximum values of 16383 and 65535 both exceed the BCD format's maximum single word capacity of 9999. Double word math would be required for 14 or 16-bit data in BCD format. **Binary data format** is also useful for displaying data on some operator interfaces.



Module 12-bit Input Resolution

When the module voltage inputs are configured for 12-bit resolution, the analog signal is converted into 4096 (2^{12}) counts ranging from 0–4095. For example, a 0V signal would be 0, and a full scale 5V or 10V signal would be 4095. This is equivalent to a binary value of 0000 0000 0000 to 1111 1111 1111, or 000 to FFF hexadecimal. The diagram shows how this relates to the signal range.

Each count can also be expressed in terms of the signal level by using the equation shown.

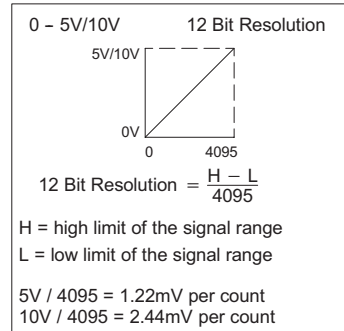

Module 14-bit Input Resolution

When the module voltage inputs are configured for 14-bit resolution, the analog signal is converted into 16384 (2^{14}) counts ranging from 0–16383. For example, a 0V signal would be 0, and a full scale 5V or 10V signal would be 16383. This is equivalent to a binary value of 00 0000 0000 0000 to 11 1111 1111 1111, or 0000 to 3FFF hexadecimal. The diagram shows how this relates to the signal range.

Each count can also be expressed in terms of the signal level by using the equation shown.

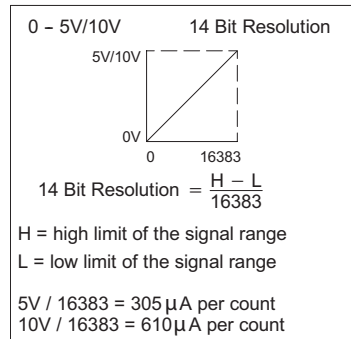

Module 16-bit Input Resolution

When the module voltage inputs are configured for 16-bit resolution, the analog signal is converted into 65536 (2^{16}) counts ranging from 0–65535. For example, a 0V signal would be 0, and a full scale 5V or 10V signal would be 65535. This is equivalent to a binary value of 0000 0000 0000 0000 to 1111 1111 1111 1111, or 0000 to FFFF hexadecimal. The diagram shows how this relates to the signal range.

Each count can also be expressed in terms of the signal level by using the equation shown.

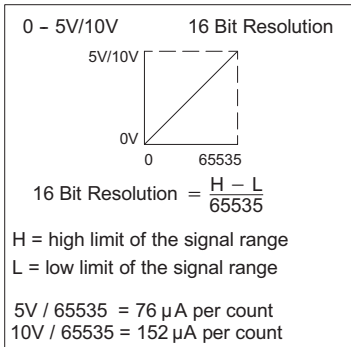

Analog and Digital Input Data Value Conversion

Sometimes it is useful to be able to quickly convert between the signal levels and the digital values. This is especially helpful during machine startup or troubleshooting. The table provides formulas to simplify the conversion.

$$A = (D)(A_{\max}) / (D_{\max})$$

$$D = (A)(D_{\max}) / (A_{\max})$$

A = Analog value from current transmitter

A_{max} = Maximum analog value

D = Digital value of input provided to PLC CPU

D_{max} = Maximum digital value

Analog and Digital Input Data Conversion			
Resolution	Input Range	If the digital value is known	If the analog signal is known
12-bit 0-4095	0-5 V	$A = (D)(5) / 4095$	$D = (A)(4095) / 5$
	0-10 V	$A = (D)(10) / 4095$	$D = (A)(4095) / 10$
14-bit 0-16383	0-5 V	$A = (D)(5) / 16383$	$D = (A)(16383) / 5$
	0-10 V	$A = (D)(10) / 16383$	$D = (A)(16383) / 10$
16-bit 0-65535	0-5 V	$A = (D)(5) / 65535$	$D = (A)(65535) / 5$
	0-10 V	$A = (D)(10) / 65535$	$D = (A)(65535) / 10$

For example, if a 0-10 V range with 16-bit resolution is being used, and the signal measured is 6V, the formula can be easily used to determine the digital value (D) that should be stored in the V-memory location that contains the data.

$$D = (A) \frac{65535}{10}$$

$$D = (6) (6553.5)$$

$$D = 39321$$

Scaling the Input Data

Most applications require measurements in engineering units, which provide more meaningful data. For input ranges with a minimum value of zero, this can be accomplished by using the conversion formulas shown below.

$$EU = (A)(EU_H - EU_L) / (A_{max})$$

$$EU = (D)(EU_H - EU_L) / (D_{max})$$

- A = analog value from current transmitter
- D = digital value of input provided to PLC CPU
- EU = engineering units
- EU_H = engineering units high value
- EU_L = engineering units low value

The following examples show a 16-bit measurement of pressure (PSI) from 0.0–140.0. The analog value needs to be multiplied by 10 in order to imply a decimal place when the value is viewed with the programming software. Notice how the calculations differ when the multiplier is used.

Scaling Example

Analog Value of 6.3 V, 0–10 V transmitter, 16-bit resolution, should yield 88.2 psi.

Example without multiplier

$$EU = (D) \frac{EU_H - EU_L}{D_{max}}$$

$$EU = (41287) \frac{140 - 0}{65535}$$

$$EU = 88$$

Example with multiplier

$$EU = (10)(D) \frac{EU_H - EU_L}{D_{max}}$$

$$EU = (10)(41287) \frac{140 - 0}{65535}$$

$$EU = 882$$



NOTE: Binary data format is recommended for **14 or 16-bit resolution input data**, especially if the input data is to be used in any math instructions (DL205 User Manual, ch.5). There is only one V-memory word (16-bits) available for the actual data. Although the 12-bit resolution maximum value of 4095 can be stored in one word using either binary or BCD formats, the 14 and 16-bit resolution maximum values of 16383 and 65535 both exceed the BCD format's maximum single word capacity of 9999. Double word math would be required for 14 or 16-bit data in BCD format. **Binary data format** is also useful for displaying data on some operator interfaces.

Input Engineering Unit Conversion Example 1:

- Data format = BCD,
- Channel 1 data memory location = V2000,
- Channel 1 resolution = 12-bits,
- Channel 1 engineering units = 0.0–140.0 PSI,
- Channel 1 input device = 0–5 V or 0–10 V transmitter.

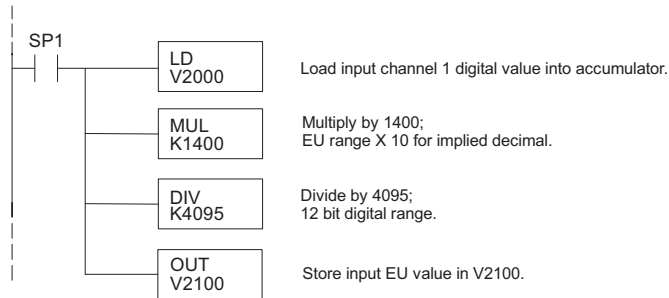

Input Engineering Unit Conversion Example 2:

- Data format = binary,
- Channel 1 data memory location = V2000,
- Channel 1 resolution = 14-bits,
- Channel 1 engineering units = 0.0–140.0 PSI,
- Channel 1 input device = 0–5 V or 0–10 V transmitter.

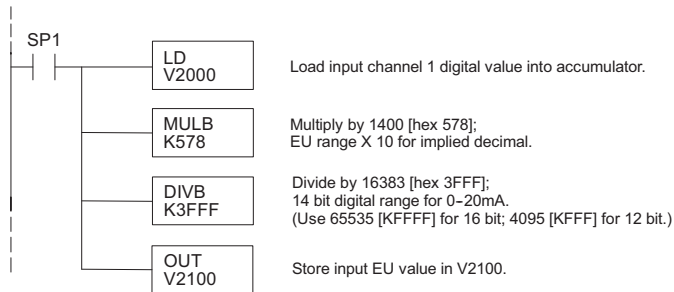

NOTE: The above examples use SP1 (which is always on) as a permissive contact for the engineering unit conversions. X, C, etc., could also be used as a permissive contact.

Input Engineering Unit Conversion Example 3:

Data format = binary,

Channel 1 data memory location = V2000,

Channel 1 resolution = 16-bits,

Channel 1 engineering units = 0.0–140.0 PSI,

Channel 1 input device = 0–5 V or 0–10 V transmitter.

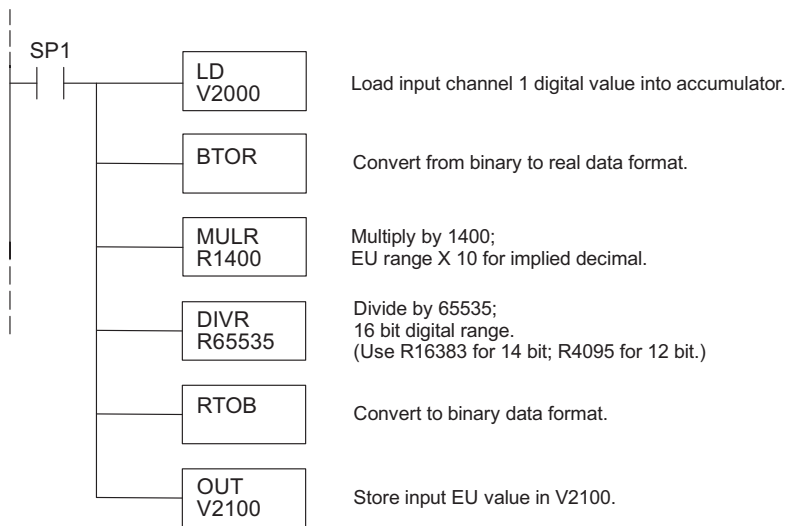

Using the Input Track and Hold Feature

The input Track and Hold feature allows the individual inputs to be separately configured to maintain their maximum or minimum data values. If No Track and Hold is selected, the present real time value of the input will be stored in the input data V-memory location. If Track and Hold minimum value is selected, the first input value less than or equal to full scale will be read and maintained until a lower value is measured, or until Track and Hold is reset. If maximum value is selected, the first input value greater than or equal to zero will be read and maintained until a higher value is measured, or until Track and Hold is reset.

To reset Track and Hold, write a value of one to the Track and Hold selection high and low bits. When Track and Hold is reset, the module will display the real-time input value. When the selection is changed from reset to minimum value or maximum value, the input will start over as described previously.

Track and Hold Example:

Number of Channels = 1 in, 1 out,
 Data Format = binary in, binary out,
 Input resolution = 16-bits,
 Input/Output Range = 0–10 V in, 0–10 V out,
 Input Track and Hold = channel 1 reset.

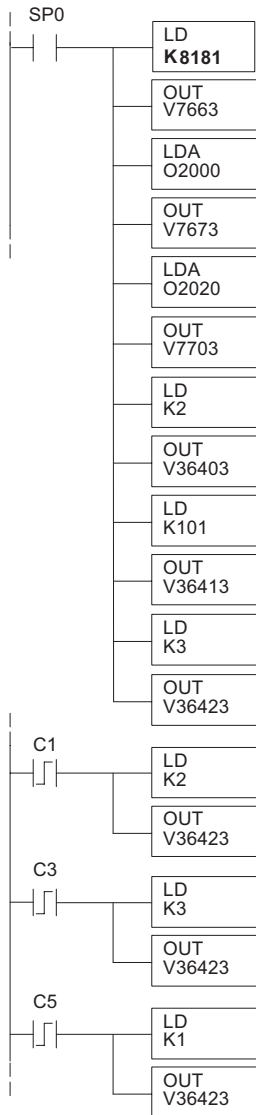

Rung 1, Module Configuration:
 Input: binary data format, 1 channel.
 Output: binary data format, 1 channel.
 Module location: local base, slot 3.
 Input data 1st memory location: V2000.
 Output data 1st memory location: V2020.
 Input resolution: 16 bit channel 1.
 Input/Output range: 0–10V in, 0–10V out.
 Input Track and Hold: reset channel 1.

C1 loads value of 2 (binary 10) into the Track and Hold Selection register. This sets input channel 1 for Track and Hold Maximum Value. As the analog value varies, only a measured value higher than the previously stored value will be written to V2000.

C3 loads a value of 3 (binary 11) into the Track and Hold Selection register. This sets input channel 1 for Track and Hold Reset Value. Real-time measured values will be written to V2000 until another Track and Hold Selection is made.

C5 loads value of 1 (binary 01) into the Track and Hold Selection register. This sets input channel 1 for Track and Hold Minimum Value. As the analog value varies, only a measured value lower than the previously stored value will be written to V2000.

Module 16-bit Output Resolution

Since the voltage output module has 16-bit resolution, the analog signal is converted into 65536 (2^{16}) counts ranging from 0-65535. For example, a 0V signal would be 0, and a full scale 5V or 10V signal would be 65535. This is equivalent to a binary value of 0000 0000 0000 0000 1111 1111 1111 1111, or 0000 to FFFF hexadecimal. The diagram shows how this relates to the signal range.

Each count can also be expressed in terms of the signal level by using the equation shown.

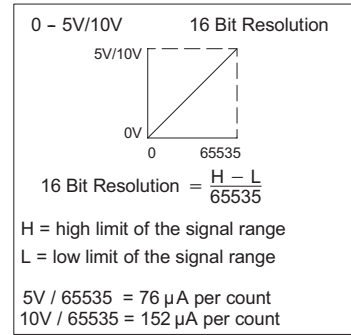

Digital and Analog Output Data Value Conversion

Sometimes it is useful to be able to quickly convert between the signal levels and the digital values. This is especially helpful during machine startup or troubleshooting. For output ranges with a minimum value of zero, the table below provides formulas to make this conversion easier.

$$A = (D)(A_{\max}) / (D_{\max})$$

$$D = (A)(D_{\max}) / (A_{\max})$$

- A = analog current output value
- A_{\max} = maximum analog value
- D = digital value from PLC CPU
- D_{\max} = maximum digital value

Output Value Comparisons:

Resolution	Output Range	If the digital value is known	If the analog signal level is known.
16-bit 0-65535	0-5 V	$A = (D)(5) / 65535$	$D = (A)(65535) / 5$
	0-10 V	$A = (D)(10) / 65535$	$D = (A)(65535) / 10$

For example, if a 6V analog output signal with a 0-10 V output range, the formula could be used to determine the digital value (D) to be stored in the V-memory location that contains the output data.

$$D = (6) \frac{65535}{10}$$

$$D = (6)(6553.5)$$

$$D = 39321$$

Analog, Digital, Engineering Units

The table to the right shows how the output analog, digital, and engineering unit values are related to each other. The example is a measurement of pressure from 0.0-140.0 psi, using a multiplier of 10 for one implied decimal place.

Output Value Comparisons			
Analog Range		Digital 16-bit	E.U.
0-5 V	0-10 V		
5	10	65535	1400
2.5	5	32768	700
0	0	0	0

Calculating the Digital Output Value

The value sent to the 16-bit analog output module must be in digital form. A very good method to do this is to convert the value into engineering units. Use the formula shown on the right to accomplish this.

Adjustments to the formula may be needed depending on the scale chosen for the engineering units.

Consider the following example which controls pressure from 0.0–140.0 psi. By using the formula, the digital value can be determined that can be sent to the module. The example shows the conversion required to yield 52.5 psi. Notice the formula divides by 10, because the BCD representation of 52.5 includes a multiplier of 10 to allow for the implied decimal. The division corrects for the multiplier.

$$D = EU \frac{D_{max}}{(EU_H - EU_L)}$$

D = digital value
 EU = engineering units
 EU_H = engineering unit range high limit
 EU_L = engineering unit range low limit

Calculating Output Data: Engineering Units Conversion

$$D = 10EU \frac{D_{max}}{10(EU_H - EU_L)} \qquad D = 525 \frac{65535}{10(140)} \qquad D = 24576$$

The below example program shows how to write the program to perform the engineering unit conversion to output the 16-bit data format of 0–65535. This example assumes that the engineering units have been calculated or loaded, including a multiplier of 10, in BCD format and stored it in V2120 for output channel 1.

Output Engineering Unit Conversion / Output Data Calculation Example:

- Data format = binary,
- Channel 1 data memory location = V2020,
- Channel 1 engineering units = 0.0–140.0 psi,

