

# F2-02DA-2, F2-02DA-2L\* 2-CHANNEL ANALOG VOLTAGE OUTPUT

---



# CHAPTER 9

## In This Chapter...

Module Specifications .....	9-2
Setting the Module Jumpers .....	9-5
Connecting and Disconnecting the Field Wiring .....	9-8
Module Operation .....	9-10
Writing the Control Program.....	9-15



---

**\*NOTE:** *The F2-02DA-2L module has been discontinued. Please consider F2-02DA-2 as a replacement.*

---

## Module Specifications

The F2-02DA-2 and \*F2-02DA-2L Analog Output modules provide several hardware features:

- Analog outputs are optically isolated from the PLC logic.
- The modules have a removable terminal block so the module can be easily removed or changed without disconnecting the wiring.
- Both channels can be updated in one scan if either a D2-240, a D2-250-1, a D2-260 or a D2-262 CPU is used in the PLC.
- F2-02DA-2: Low-power CMOS design requires less than 60mA from an external 24VDC power supply.
- \*F2-02DA-2L: Low-power CMOS design requires less than 70mA from an external 12VDC power supply.
- Outputs can be independently configured for any of the following ranges:
  1. 0–5 VDC
  2. 0–10 VDC
  3.  $\pm 5$ VDC
  4.  $\pm 10$ VDC

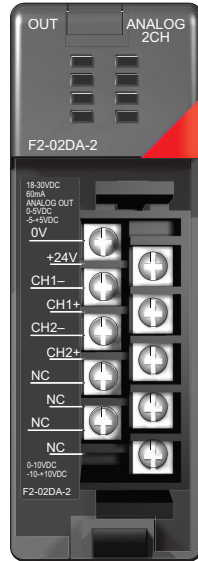

F2-02DA-2

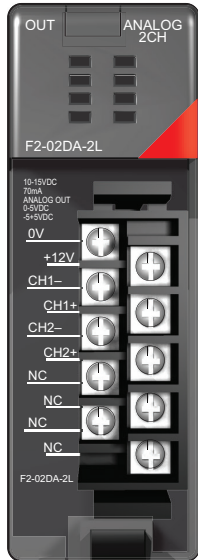

\*F2-02DA-2L



**NOTE:** The F2-02DA-2 and F2-02DA-2L modules look very similar and it is very easy to mistake one module for the other. If the module being used does not work, check the terminal label to see if it is a 12V (L) or a 24V model and that it is being supplied with the proper input voltage.

### Analog Output Configuration Requirements

The F2-02DA-2(L) analog output module requires 16 discrete output points. The module can be installed in any slot of a DL205 PLC, but the available power budget and discrete I/O points are the limiting factors. Check the DL205 PLC User Manual for the particular model of CPU and I/O base being used for information regarding power budget and number of local, local expansion or remote I/O points.



**NOTE:** The F2-02DA-2L module has been discontinued. Please consider F2-02DA-2 as a replacement.

The following tables provide the specifications for the F2-02DA-2 and \*F2-02DA-2L Analog Output Modules.

Output Specifications	
<b>Number of Channels</b>	2
<b>Output Range</b>	0-5V, 0-10V, $\pm 5V$ , $\pm 10V$
<b>Resolution</b>	12 bit (1 in 4096)
<b>Output Type</b>	Single ended, 1 common
<b>Peak Output Voltage</b>	15VDC (clamped by transient voltage suppressor)
<b>Load Impedance</b>	2000 $\Omega$ minimum
<b>Load Capacitance</b>	0.01 $\mu F$ maximum
<b>Linearity Error (end to end)</b>	$\pm 1$ count ( $\pm 0.025\%$ of full scale) maximum
<b>Conversion Settling Time</b>	5 $\mu s$ maximum (full scale change)
<b>Full-scale Calibration Error (offset error included)</b>	$\pm 12$ counts maximum, @ 25°C (77°F) unipolar $\pm 16$ counts maximum, @ 25°C (77°F) bipolar
<b>Offset Calibration Error</b>	$\pm 3$ counts maximum, @ 25°C (77°F) unipolar $\pm 8$ counts maximum, @ 25°C (77°F) bipolar
<b>Maximum Inaccuracy</b>	Unipolar ranges $\pm 0.3\%$ @ 25°C (77°F) $\pm 0.45\%$ 0-60°C (32-140°F) Bipolar ranges $\pm 0.4\%$ @ 25°C (77°F) $\pm 0.55\%$ 0-60°C (32-140°F)
<b>Accuracy vs. Temperature</b>	$\pm 50$ ppm/°C full scale calibration change; (including maximum offset change of 2 counts)

General Specifications	
<b>PLC Update Rate</b>	1 channel per scan maximum (D2-230 CPU) 2 channels per scan maximum (D2-240, D2-250-1, D2-260 and D2-262 CPUs)
<b>Digital Outputs Output Points Required</b>	12 binary data bits, 2 channel ID bits, 1 sign bit 16 point (Y) output module
<b>Power Budget Requirement</b>	40mA @ 5VDC (supplied by the base)
<b>External Power Supply</b>	F2-02DA-2: 24-30 VDC ( $\pm 10\%$ ), 60mA (outputs fully loaded) F2-02DA-2L: 12VDC ( $\pm 10\%$ ), 70mA (outputs fully loaded)
<b>Operating Temperature</b>	0-60°C (32-140°F)
<b>Storage Temperature</b>	-20°C to 70°C (-4°F to 158°F)
<b>Relative Humidity</b>	5-95% (non-condensing)
<b>Environmental Air</b>	No corrosive gases permitted
<b>Vibration</b>	MIL STD 810C 514.2
<b>Shock</b>	MIL STD 810C 516.2
<b>Noise Immunity</b>	NEMA ICS3-304

**\*NOTE:** The F2-02DA-2L module has been discontinued. Please consider F2-02DA-2 as a replacement.



### Special Placement Requirements (D2-230 and Remote I/O Bases)

It is important to examine the configuration if a D2-230 CPU is being used. As can be seen in the section on **Writing the Control Program**, V-memory locations are used to hold the analog data that will be written to the output. If the module is placed in a slot such that the output points do not start on a V-memory boundary, the program instructions aren't able to access the data. This also applies when placing this module in a remote base using a D2-RSSS in the CPU slot.

**Correct!**

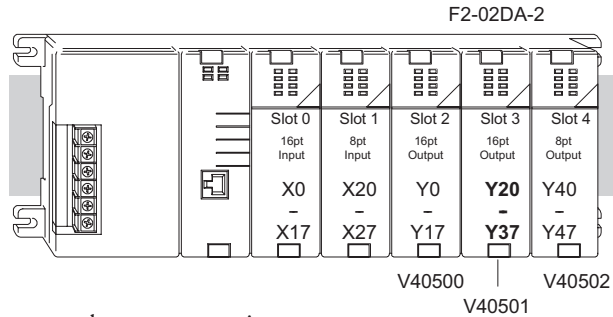

Data is correctly entered, so output points start on a V-memory boundary.

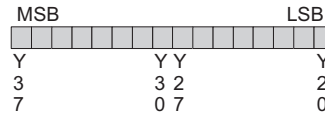

**Incorrect**

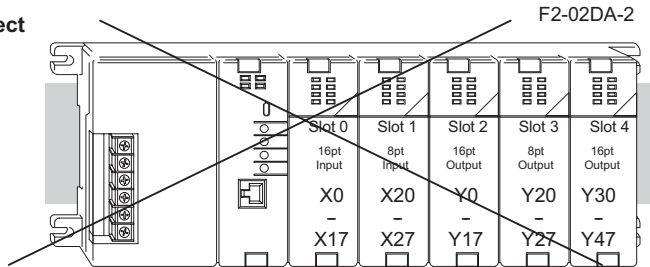

Data is split over three locations, so instructions cannot access data from a D2-230.

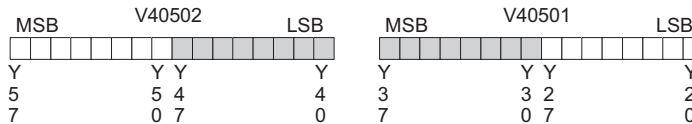

To use the V-memory references required for a D2-230 CPU, the first output address assigned to the module must be one of the following Y locations. The table also shows the V-memory addresses corresponding to these Y locations.

<b>X</b>	Y0	Y20	Y40	Y60	Y100	Y120	Y140	Y160
<b>V</b>	V40500	V40501	V40502	V40503	V40504	V40505	V40506	V40507

## Setting the Module Jumpers

The F2-02DA-2 (L) Analog Output module uses jumpers for selecting the voltage ranges for each channel. The range of each channel can be independently set. Available operating ranges are 0–5 V, 0–10 V,  $\pm 5$ V, and  $\pm 10$ V.

There are three jumpers for each channel. Two sets are on the top board, and the third set is along the edge of the bottom board with the black D-shell backplane connector. Install or remove these jumpers to select the desired range. Unused jumpers can be stored on a single pin so they do not get lost.

- Two of the top board jumpers are labeled “UNI /  $\pm 5$ ” and there is one for each channel.
- The two bottom board jumpers are labeled “UNI” and there is one for each channel. These jumpers determine the format of the channel output data, and the effect of their settings is independent from that of the other jumpers on the module. With a UNI jumper removed, the corresponding channel requires data values in the range of  $\pm 2047$ . With a UNI jumper installed, the channel requires data values in the range of 0–4095.
- The other two top board jumpers are labeled “BI-P0-5” and there is one for each channel. These jumpers each have three possible settings (including jumper removed) since there are three pins.



**NOTE:** It is important to set the module jumpers correctly. The module will not operate correctly if the jumpers are not properly set for the desired voltage range.

This figure shows the jumper locations. See the table on the following page to determine the proper settings for your application.

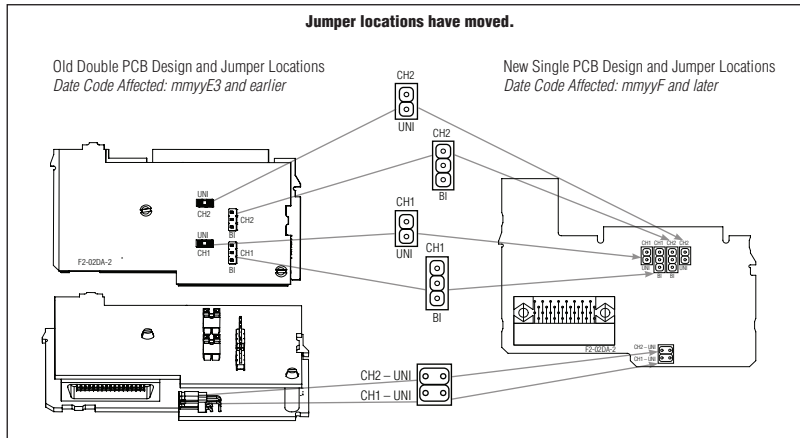

### Voltage Range and Output Combinations

The table lists the eight possible combinations of voltage ranges and data formats, along with the corresponding jumper settings. For most applications, use one of the four standard selections (indicated by an asterisk) in the table below. Standard unipolar voltage ranges accept a data format of 0–4095. Standard bipolar ranges accept a data format of -2047 to +2047.

Voltage Range and Output Combinations					
Voltage Range	Output Data Format	UNI / $\pm 5V$ Jumper Settings (top board)	UNI Output Format Jumper Settings (bottom board)	BI-P 0–5 V Jumper Settings (top board)	
				BI-P (Bipolar) Position	0–5 V Position
0–5 V *	0–4095 *	Install	Install		Install here
0–10 V *	0–4095 *	Install	Install	Completely remove	
0–5 V	$\pm 2047$	Install	Remove		Install here
0–10 V	$\pm 2047$	Install	Remove	Completely remove	
$\pm 5V$ *	$\pm 2047$ *	Install	Remove	Install here	
$\pm 10V$ *	$\pm 2047$ *	Remove	Remove	Install here	
$\pm 5V$	0–4095	Install	Install	Install here	
$\pm 10V$	0–4095	Remove	Install	Install here	

Standard selections are shown with an \*.

For example, to select settings of “ $\pm 5V$ ” voltage range with a “ $\pm 2047$ ” output data format for channel 1, refer to the table above and the figure on the previous page and arrange the jumpers as follows:

- Install the “CH1 UNI /  $\pm 5V$ ” jumper.
- Remove the “CH1-UNI” jumper. Store the jumper so it does not get lost by placing it on one pin.
- Install the “CH1” “BI-P0-5” jumper in the BI-P (bipolar) position on the left pin and center pin.

The non-standard selections in the table provide the opposite data format for both unipolar and bipolar voltage ranges. If you are using unipolar output (0-5 V or 0-10 V) on one channel and bipolar output ( $\pm 5V$ ,  $\pm 10V$ ) on the other channel, then one of the outputs will use a non-standard data format.

The following graphs show the voltage range to output data format relationship for each of the eight selections.

**Unipolar Ranges**

]

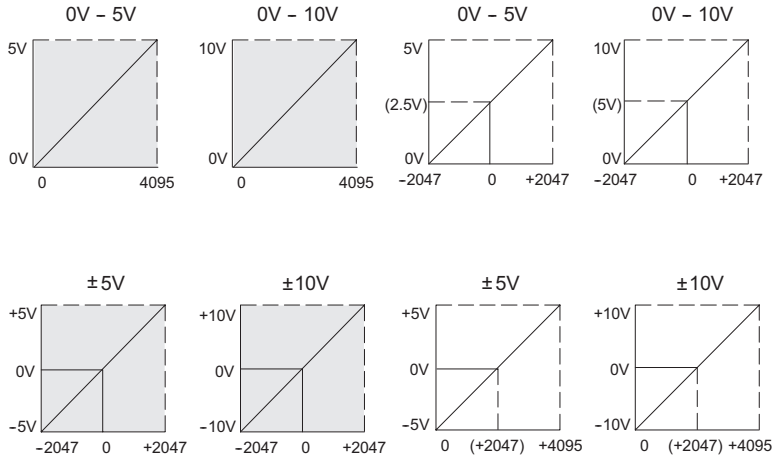

## Connecting and Disconnecting the Field Wiring

### Wiring Guidelines

Your company may have guidelines for wiring and cable installation. If so, check the guidelines before beginning the installation. Here are some general things to consider:

- Use the shortest wiring route whenever possible.
- Use shielded wiring and ground the shield at the transmitter source. Do not ground the shield at both the module and the source.
- Do not run the signal wiring next to large motors, high current switches, or transformers. This may cause noise problems.
- Route the wiring through an approved cable housing to minimize the risk of accidental damage. Check local and national codes to choose the correct method for your application.

### User Power Supply Requirements

The F2-02DA-2 (L) module requires at least one field-side power supply. The same or separate power sources can be used for the module supply and the voltage transmitter supply. The F2-02DA-2 module requires 18–30 VDC, at 60mA and the \*F2-02DA-2L module requires 10–15 VDC, at 70mA, from the external power supply.

The DL205 AC bases have a built-in 24VDC power supply that provide up to 300mA of current. This can be used instead of a separate supply. Check the power budget to be safe.

It is desirable in some situations to power the transmitters separately in a location remote from the PLC. This will work as long as the transmitter supply meets the voltage and current requirements, and the transmitter negative (-) side and the module supply negative (-) side are connected together..



---

**WARNING:** If the internal 24VDC base power is used, be sure to calculate the power budget. Exceeding the power budget can cause unpredictable system operation that can lead to a risk of personal injury or equipment damage.

---



---

**\*NOTE:** The F2-02DA-2L module has been discontinued. Please consider F2-02DA-2 as a replacement.

---



## Wiring Diagram

The F2-02DA-2(L) module has a removable connector which helps to simplify wiring. Just squeeze the top and bottom retaining clips and gently pull the connector from the module. Use the following diagram to connect the field wiring.

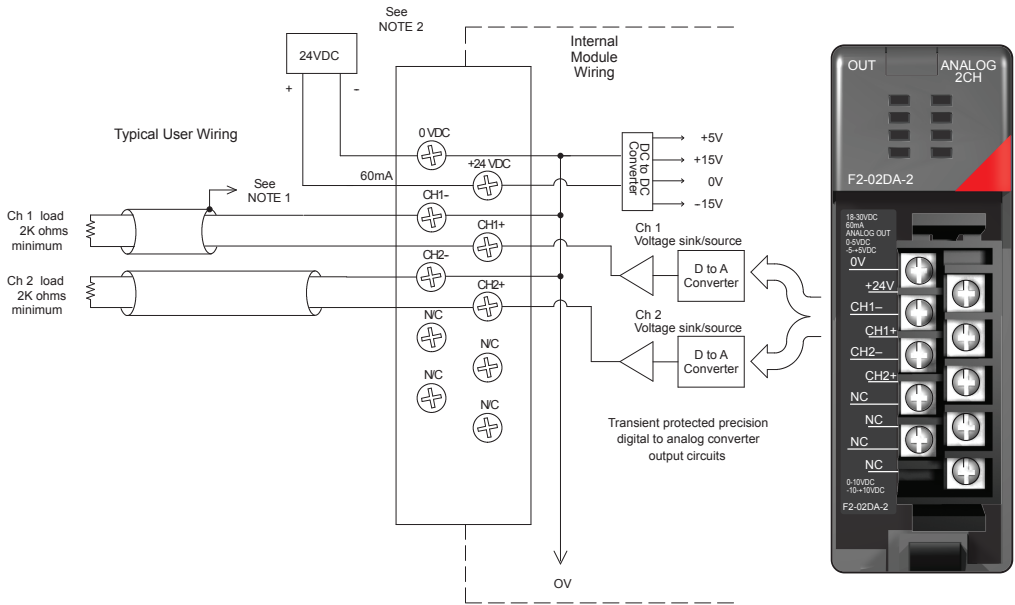

**NOTE 1:** Shields should be connected to the 0V terminal of the module or 0V of the power supply.

**NOTE 2:** The F2-02DA-2L module must use a 12VDC, at 70mA, external power supply.

**NOTE 3:** Unused voltage outputs should remain open (no connections) for minimum power consumption.

## Module Operation

Before beginning to write the control program, it is important to take a few minutes to understand how the module processes the analog signals.

### Channel Scanning Sequence (Multiplexing) for a D2-230 CPU

The D2-230 can send one channel of data per CPU scan. The module refreshes two field devices on each scan, but new data can only be obtained from the CPU at the rate of one channel per scan. Since there are two channels, it can take two scans to update both channels. However, if only one channel is being used, then that channel will be updated on every scan. The multiplexing method can also be used for the D2-240, D2-250-1, D2-260 and D2-262 CPUs.

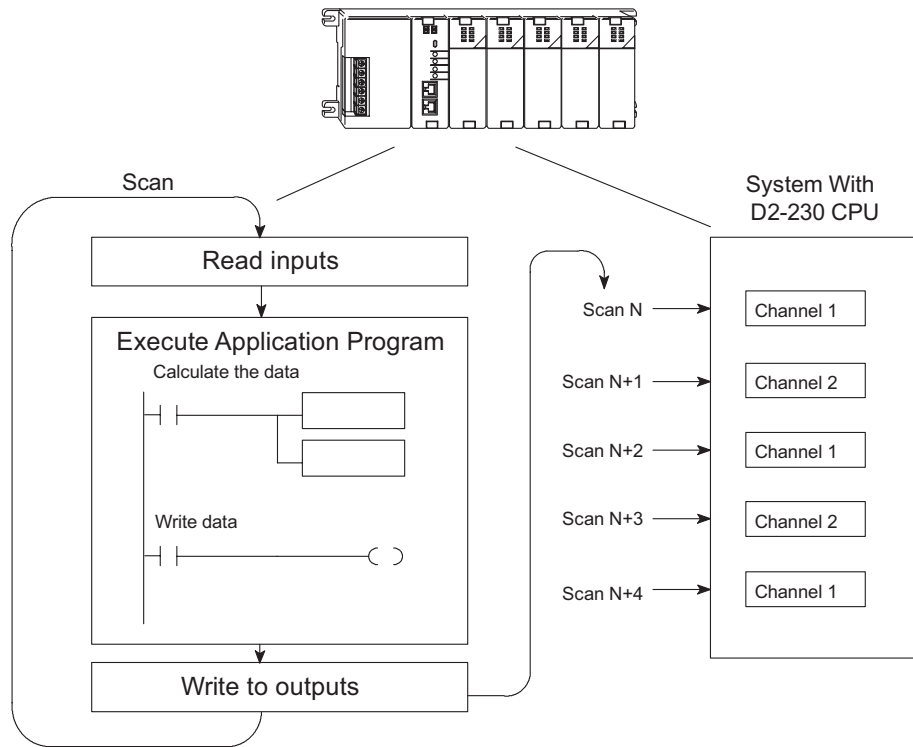

### Channel Scanning Sequence (Pointer Method) for D2-240, D2-250-1, D2-260 and D2-262 CPUs

If either a D2-240, D2-250-1, D2-260 or D2-262 CPU is used, both channels can be updated on every scan. These CPUs support special V-memory locations that are used to manage the data transfer. This is discussed in more detail in the section **Writing the Control Program** later in this chapter.

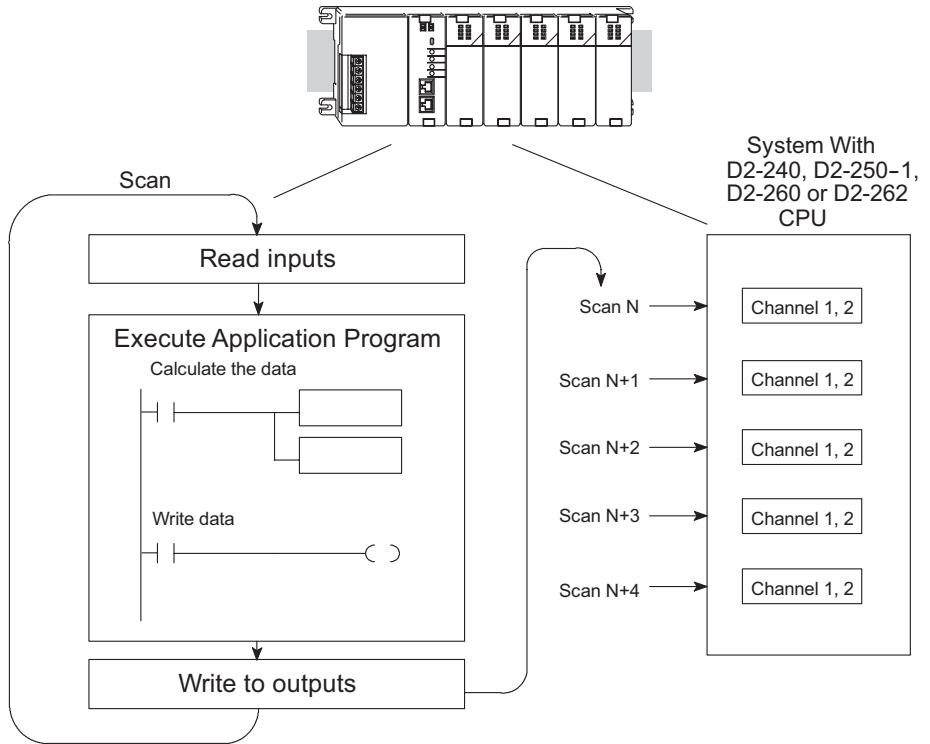

### Understanding the Output Assignments

Remember that the F2-02DA-2 (L) module appears to the CPU as a 16-point discrete output module. These points provide the data value and an indication of which channel to update. Note, if either a D2-240, DL250-1, D2-260 or D2-262 CPU is being used, these bits may never have to be used, but it may be an aid to help understand the data format.

Since all output points are automatically mapped into V-memory, the location of the data word that will be assigned to the module can be simply determined.

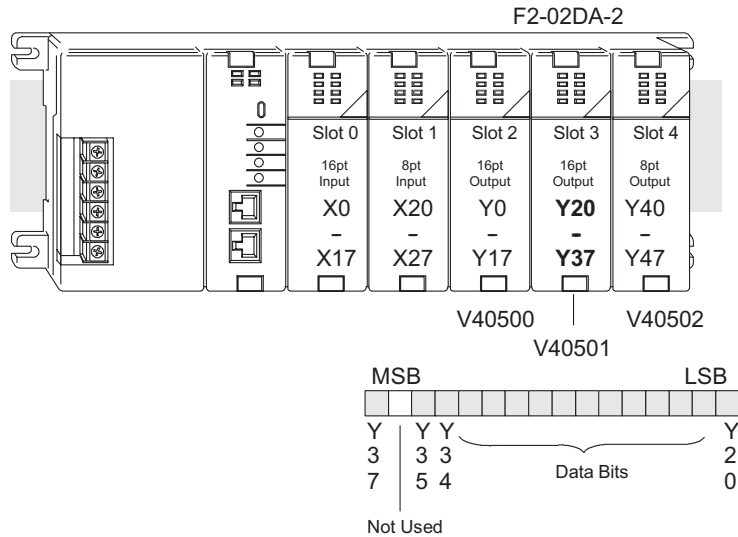

The individual bits in this data word location, represents specific information about the analog signal.

### Channel Select Outputs

Two of the outputs select the active channel. Remember, the V-memory bits are mapped directly to discrete outputs. Turning a bit OFF selects its channel. By controlling these outputs, the channel(s) to be updated can be selected.

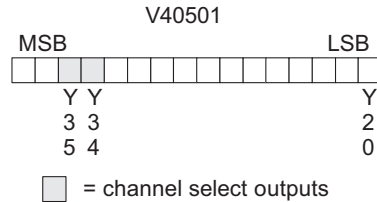

Y35	Y34	Channel
On	Off	1
Off	On	2
Off	Off	1 & 2 (same data to both channels)
On	On	None (both channels hold current values)

### Analog Data Bits

The first twelve bits represent the analog data in binary format.

Bit	Value	Bit	Value
0	1	6	64
1	2	7	128
2	4	8	256
3	8	9	512
4	16	10	1024
5	32	11	2048

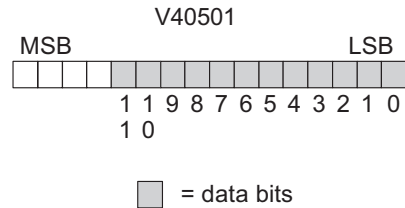

### Signal Sign Output

The last output can be used to select the signal sign (+ or -) for bipolar ranges. By controlling this output, positive and negative data values can be easily selected.

Programming examples in the next section, **Writing the Control Program**, will show how to make sign selection part of the program.

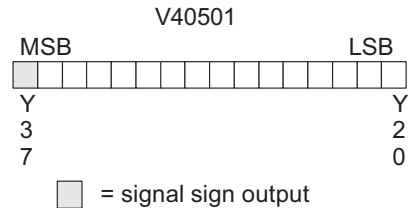

### Bipolar Output Data

If an output channel is configured for an output format of 0–2047, the maximum valid value for the lower 12 bits is 2047. This means that bit 11 (bit position 12) must always be 0 (zero).

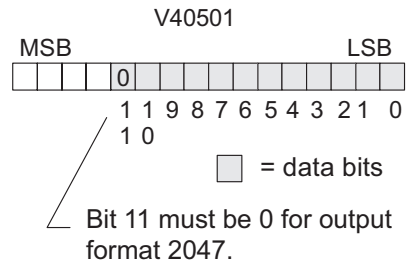

**WARNING:** If the data value exceeds 2047, bit 11 becomes a "1", and the other eleven bits start over at "00000000000". At this point the module's channel output voltage also goes back to the bottom of its range and begins to increase again. The RLL program will be expecting a maximum output, but it will be minimum instead. This can have serious consequences in some applications, and may result in personal injury or damage to equipment. Therefore, in standard bipolar ranges (or whenever the output format is  $\pm 2047$  in general), be sure that the RLL program does not create numbers with absolute values greater than 2047.

### Module Resolution

Since the module has 12-bit resolution, the analog signal is converted into 4096 counts ranging from 0–4095 ( $2^{12}$ ). For example, with a 0–10 V range, send a 0 to get a 0V signal, and send 4095 to get a 10V signal. This is equivalent to a binary value of 0000 0000 0000 to 1111 1111 1111, or 000 to FFF hexadecimal.

Each count can also be expressed in terms of the signal level by using the following equation.

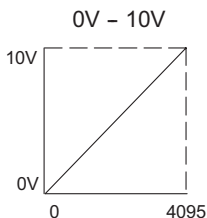

$$\text{Resolution} = \frac{H - L}{4095}$$

H = High limit of the signal range

L = Low limit of the signal range

Voltage Range	Signal Span	Divide By	Smallest Output Change
<b>0–5 V</b>	5V	4095	1.22 mV
<b>0–10 V</b>	10V	4095	2.44 mV
<b>± 5V</b>	10V	4095	2.44 mV
<b>± 10V</b>	20V	4095	4.88 mV

The following table shows the smallest change in signal level due to a digital value change of 1 LSB count.

## Writing the Control Program

### Calculating the Digital Value

The control program must calculate the digital value that is sent to the analog output. Several methods can be used to do this, but the best method is to convert the values to engineering units. This is accomplished by using the formula shown.

Adjustments may have to be made to the formula depending on the scale of the engineering units.

$$A = U \frac{4095}{H - L} \quad \text{for 0-4095 output format}$$

$$A = U \frac{2047}{H - L} \quad \text{for 0-2047 output format}$$

A = Analog Value (0 – 4095)

U = Engineering Units

H = High limit of the engineering unit range

L = Low limit of the engineering unit range

Consider the following example which controls pressure from 0.0–99.9 psi. Using the formula will calculate the digital value to be sent to the analog output. The example shows the conversion required to yield 49.4 psi. The multiplier of 10 is because the decimal portion of 49.4 cannot be loaded in the program, so it is shifted right one decimal place to make a usable value of 494.

Refer to the example on the next page to write the conversion program.

$$A = 10U \frac{4095}{10(H - L)} \quad A = 494 \frac{4095}{1000 - 0} \quad A = 2023$$

### The Conversion Program

This example program shows how to write the program to perform the engineering unit conversion to output data formats 0–4095. This example assumes that a BCD value has been stored in V2300 and V2301 for channels 1 and 2 respectively.



**NOTE:** The DL205 has many instructions available so that math operations can simply be performed using BCD format. Do the math in BCD, then convert to binary before writing to the module output.

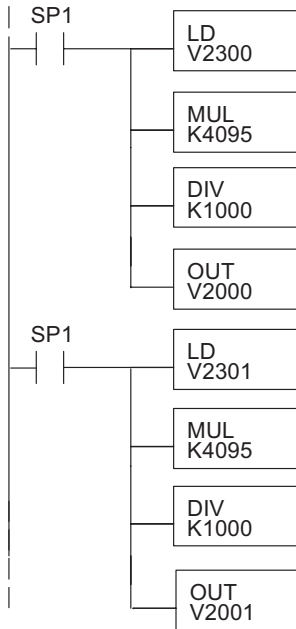

The LD instruction loads the engineering units used with channel 1 into the accumulator. This example assumes the numbers are BCD. Since SP1 is used, this rung automatically executes on every scan. You could also use an X, C, etc. permissive contact.

Multiply the accumulator by 4095 (to start the conversion).

Divide the accumulator by 1000 (because we used a multiplier of 10, we have to use 1000 instead of 100).

Store the BCD result in V2000 (the actual steps required to send the data are shown later).

The LD instruction loads the engineering units used with channel 2 into the accumulator. This example assumes the numbers are BCD. Since SP1 is used, this rung automatically executes on every scan. You could also use an X, C, etc. permissive contact.

Multiply the accumulator by 4095 (to start the conversion).

Divide the accumulator by 1000 (because we used a multiplier of 10, we have to use 1000 instead of 100).

Store the BCD result in V2001 (the actual steps required to send the data are shown later).



## Negative Values with Bipolar Range

If the bipolar ranges ( $\pm 5V$ ,  $\pm 10V$ ) are used or an output data format of  $\pm 2047$ , the data value needs to be specified whether it is positive or negative. There are two ways to show that the value is negative:

- Turn on the sign output (Y37 in the examples, D2-230 only).
- Embed the sign output in the data value (required for the D2-240, D2-250-1, D2-260 and D2-262 using the pointer method, an optional method for the D2-230).

To embed the sign output in the data values, OR 8000 to the value. This has the same effect as turning on Y37. Remember, the V-memory location is mapped directly to the outputs.

If bipolar ranges are used, logic needs to be added to indicate either positive or negative values. The logic would be similar for both values, but some type of permissive contact needs to be used to select the appropriate section of logic. Following is an example that re-scales a variable from a 0–1000 range to a 0–2047 range. It includes a step that combines 8000 with the value to make it negative.



**NOTE:** Do not exceed a value of 2047 for  $\pm 2047$  output formats.

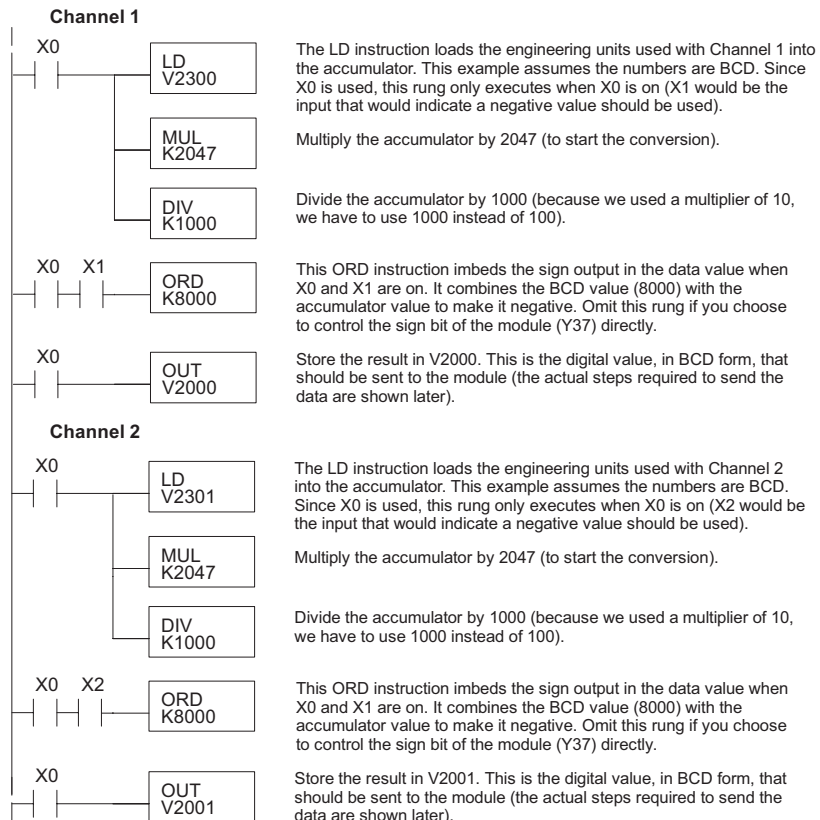

### Writing Values: Pointer Method and Multiplexing

There are two methods which can be used to write values from the CPU to the module:

- The pointer method
- Multiplexing

The multiplexing method must be used when using a D2-230 CPU. The multiplexing method must also be used with remote I/O modules (the pointer method will not work). Either method can be used with the D2-240, D2-250-1, D2-260 and D2-262 CPUs, however, the pointer method will simplify programming the PLC.

### Writing Values (Pointer Method) for D2-240, D2-250-1, D2-260 and D2-262 CPUs

The D2-240, D2-250-1, D2-260 and D2-262 CPUs have special V-memory locations assigned to each base slot that will greatly simplify the programming requirements.

These V-memory locations allow you to:

- Specify the data format
- Specify the number of channels to scan
- Specify the location of the data that will be written to the module



**NOTE:** D2-240 CPUs with firmware release version 1.5 or later and D2-250-1 CPUs with firmware release version 1.06 or later support this method.

The following example program shows how to setup these locations. Place this rung anywhere in the ladder program, or in the initial stage if stage programming instructions are being used. V2000 is used in the example but any user V-memory location can be used. In this example the module is installed in slot 3. Be sure to use the V-memory locations for the module placement. The pointer method automatically converts values to BCD.

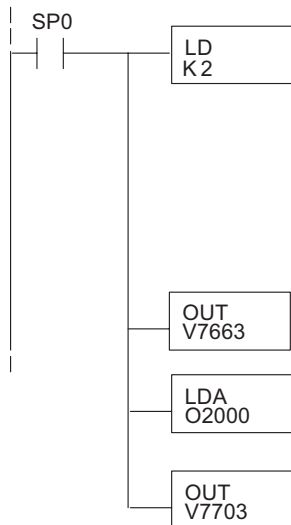

- or -

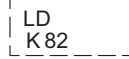

Loads a constant that specifies the number of channels to scan and the data format. The lower byte, most significant nibble (MSN) selects the data format (i.e. 0=BCD, 8=Binary), the LSN selects the number of channels (1 or 2).

The binary format is used for displaying data on some operator interfaces. The D2-230 and D2-240 CPUs do not support binary math functions, whereas the D2-250-1, D2-260, and D2-262 do.

Special V-memory location assigned to slot 3 that contains the number of channels to scan.

This loads an octal value for the first V-memory location that will be used to store the output data. For example, the O2000 entered here would designate the following addresses.

Ch1 - V2000, Ch2 - V2001

The octal address (O2000) is stored here. V7703 is assigned to slot 3 and acts as a pointer, which means the CPU will use the octal value in this location to determine exactly where to store the output data.

The following tables show the special V-memory locations used by the D2-240, D2-250-1, D2-260 and D2-262 for the CPU base and local expansion base I/O slots. Slot 0 (zero) is the module next to the CPU or D2-CM module. Slot 1 is the module two places from the CPU or D2-CM, and so on. Remember, the CPU only examines the pointer values at these locations after a mode transition. Also, if the D2-230 (multiplexing) method is used, verify that these addresses in the CPU are 0 (zero).

The table below applies to the D2-240, D2-250-1, D2-260 and D2-262 CPU base.

CPU Base: Analog Output Module Slot-Dependent V-memory Locations								
Slot	0	1	2	3	4	5	6	7
No. of Channels	V7660	V7661	V7662	V7663	V7664	V7665	V7666	V7667
Storage Pointer	V7700	V7701	V7702	V7703	V7704	V7705	V7706	V7707

The table below applies to the D2-250-1, D2-260 and D2-262 CPU base 1.

Expansion Base D2-CM #1: Analog Output Module Slot-Dependent V-memory Locations								
Slot	0	1	2	3	4	5	6	7
No. of Channels	V36000	V36001	V36002	V36003	V36004	V36005	V36006	V36007
Storage Pointer	V36020	V36021	V36022	V36023	V36024	V36025	V36026	V36027

The table below applies to the D2-250-1, D2-260 and D2-262 CPU base 2.

Expansion Base D2-CM #2: Analog Output Module Slot-Dependent V-memory Locations								
Slot	0	1	2	3	4	5	6	7
No. of Channels	V36100	V36101	V36102	V36103	V36104	V36105	V36106	V36107
Storage Pointer	V36120	V36121	V36122	V36123	V36124	V36125	V36126	V36127

The table below applies to the D2-260 and D2-262 CPU base 3.

Expansion Base D2-CM #3: Analog Output Module Slot-Dependent V-memory Locations								
Slot	0	1	2	3	4	5	6	7
No. of Channels	V36200	V36201	V36202	V36203	V36204	V36205	V36206	V36207
Storage Pointer	V36220	V36221	V36222	V36223	V36224	V36225	V36226	V36227

The table below applies to the D2-260 and D2-262 CPU base 4.

Expansion Base D2-CM #4: Analog Output Module Slot-Dependent V-memory Locations								
Slot	0	1	2	3	4	5	6	7
No. of Channels	V36300	V36301	V36302	V36303	V36304	V36305	V36306	V36307
Storage Pointer	V36320	V36321	V36322	V36323	V36324	V36325	V36326	V36327

## Writing Data (Multiplexing)

The D2-230 CPU does not have the special V-memory locations that allows for automatic management of data transfer. Since all channels are multiplexed into a single data word, the control program must be written in such a way to determine which channel to write the data to. Since the module appears as Y output points to the CPU, it is very easy to use the channel selection outputs to determine which channel to update.

The following example is for a module installed as shown in previous examples. The addresses used would be different if the module were located in a different slot. These rungs can be placed anywhere in the user program or, if using stage programming, placed in an active stage.

This example is a two-channel multiplexer that updates each channel on alternate scans. Relay SP7 is a special relay that is on for one scan, then off for one scan. A permissive contact on the last rung handles an embedded sign bit.



**NOTE:** Use binary data to write to the module outputs. Do not use a BIN instruction if the data is already in binary format.

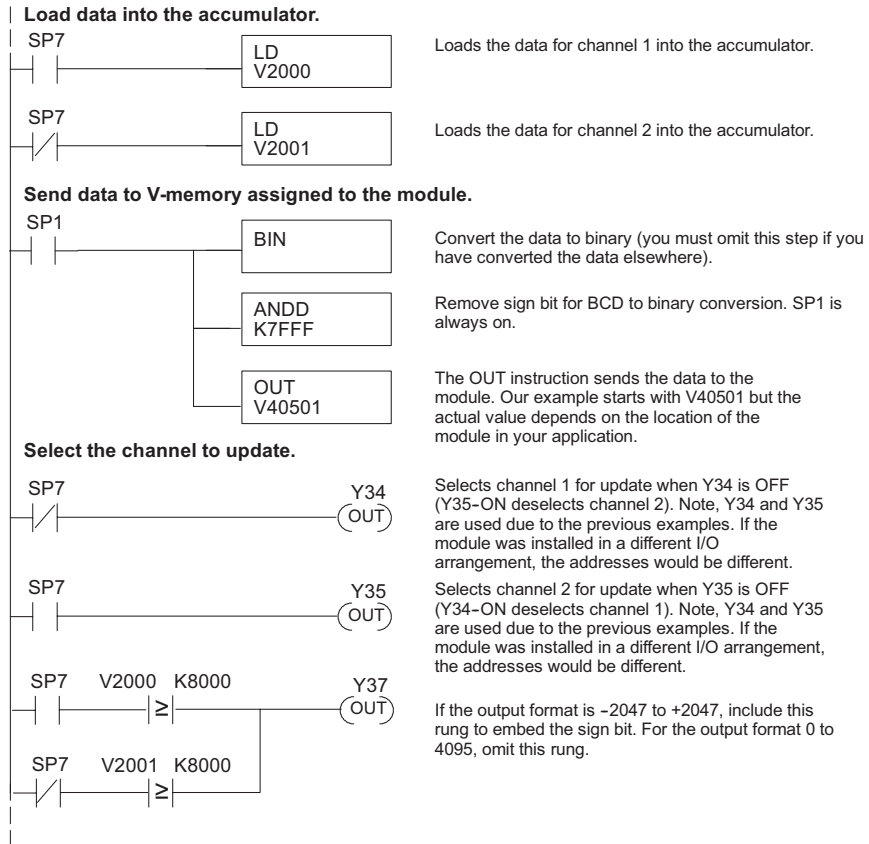

If the output range format of  $\pm 2047$  is used (also most commonly used with bipolar voltage ranges), the data values must be specified as either positive or negative. The previous example could be used with an addition to activate the sign output bit, or use the following example which uses individual contacts to determine the sign bit status for each channel.



**WARNING: DO NOT USE THIS METHOD** if the sign information is embedded into the data value by adding 8000 to it. Use the previous example.

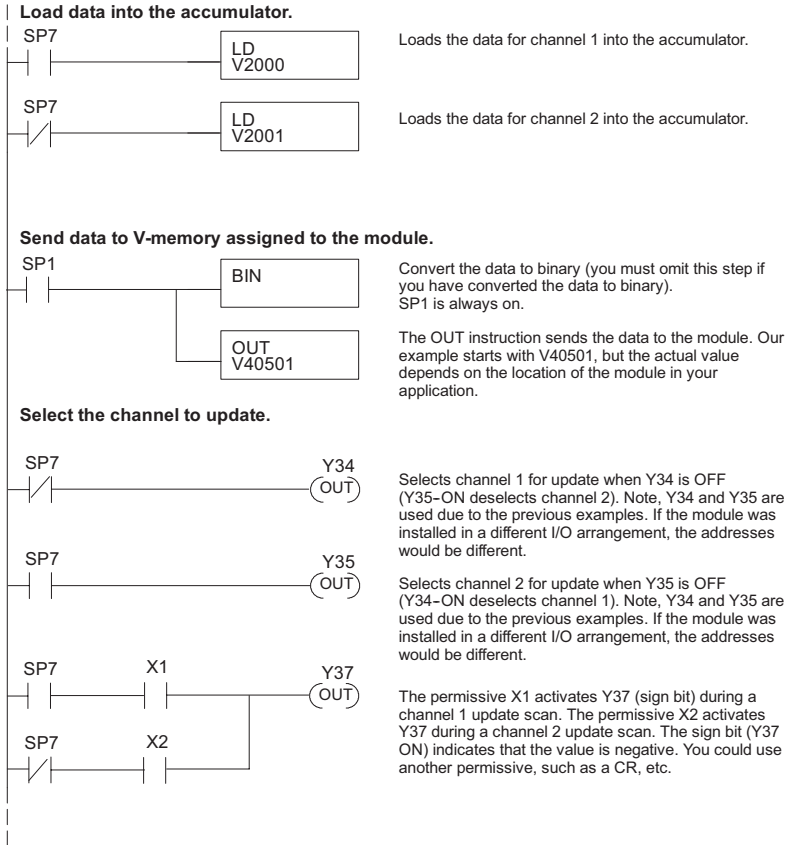

**NOTE:** Do not exceed a value of 2047 for  $\pm 2047$  output data formats.

## Write Data to One Channel

The following example can be used if only one channel is to be written to, or if the outputs are to be controlled individually. Don't forget to either embed the sign information or use the sign output bit for bipolar ranges. In this example below, data is written to output channel 1.

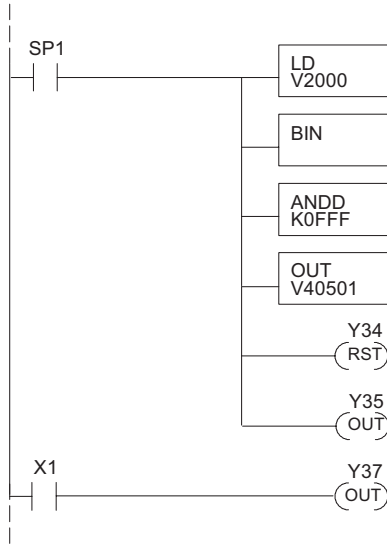

The LD instruction loads the data into the accumulator. Since SP1 is used, this rung automatically executes on every scan. You could also use an X, C, etc. permissive contact.

The BIN instruction converts the accumulator data to binary (you must omit this step if you have already converted the data elsewhere).

The ANDD instruction masks off the channel select bits to prevent an accidental channel selection.

The OUT instruction sends the data to the module. Our example starts with V40501, but the actual value depends on the location of the module in your application.

Y34-OFF selects channel 1 for updating.

Y35-ON deselects channel 2 (do not update).

The permissive X1 activates Y37, which is the sign bit. The sign bit indicates that the value is negative. You could use another permissive, such as a CR, etc. Omit this rung if you are using the 0 to +4095 output format.

## Write Data to Both Channels

In the example below, if both selection channels are off, they will be updated with the same data. Remember to either embed the sign information or use the sign output bit.

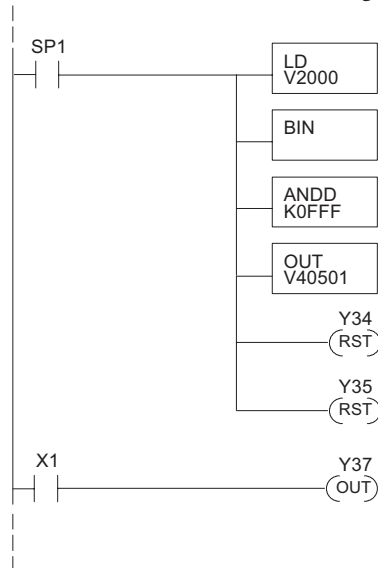

The LD instruction loads the data into the accumulator. Since SP1 is used, this rung automatically executes on every scan. You could also use an X, C, etc. permissive contact.

The BIN instruction converts the accumulator data to binary (you must omit this step if you have already converted the data elsewhere).

The ANDD instruction masks off the channel select bits to prevent an accidental channel selection.

The OUT instruction sends the data to the module. Our example starts with V40501, but the actual value depends on the location of the module in your application.

Y34-OFF selects channel 1 for updating.

Y35-OFF selects channel 2 for updating.

The permissive X1 activates Y37, which is the sign bit. The sign bit indicates that the value is negative. You could use another permissive, such as a CR, etc. Omit this rung if you are using the 0 to +4095 output format.

### Analog and Digital Value Conversions

It is sometimes useful to do quick conversions between the signal levels and the digital values. This can be helpful during startup or troubleshooting. The following table shows some formulas to help with the conversions.

Range	The digital value is known	The analog signal level is known
0–10V	$A = \frac{10D}{4095}$	$D = \frac{4095}{10} (A)$
±10V (output format ±2047)	$A = \frac{10D}{2047}$	$D = \frac{2047}{10} (A)$
0–5V	$A = \frac{5D}{4095}$	$D = \frac{4095}{5} (A)$
± 5V (output format ±2047)	$A = \frac{5D}{2047}$	$D = \frac{2047}{5} (A)$

For example, if a ±10V range with an output format of ±2047 is used, and a 6V signal level is needed, use the formula to the right to determine the digital value “D” to be stored in the V-memory location which contains the data.

$$D = \frac{2047}{10} (A)$$

$$D = \frac{2047}{10} (6V)$$

$$D = (204.7) (6)$$

$$D = 1228$$