Appendix A

RLL Communications

Programs

Why do you need a communications program?

The Master Initiates Requests

Since **DirectNET** is a master / slave network, the master station must initiate requests for network data transfers. If you're using a PLC as the master station, you use simple RLL instructions to initiate the requests.

Why Ladder Logic?

Since the DCM network interface does not contain a program, you have to use the PLC to issue the commands to tell the DCM where to read or write data. The DCM gets information from the PLC and then converts the information into the appropriate **DirectNET** commands. The RLL instructions identify the following items.

1. Slot location of the DCM master and the slave station address. (LD instruction)
2. Amount of data (in bytes) you want to transfer. (LD instruction)
3. Area of memory to be used by the master. (LDA instruction)
4. Area of memory to be used by the slave, and whether it is a read or write operation. (RX or WX instruction)
5. Interlocks for communication timing and multiple RX and WX routines.

This example reads 3 bytes of data from Slave Address #1, (starting at Y0), into the Master PLC starting at V40600 (Control Relays).

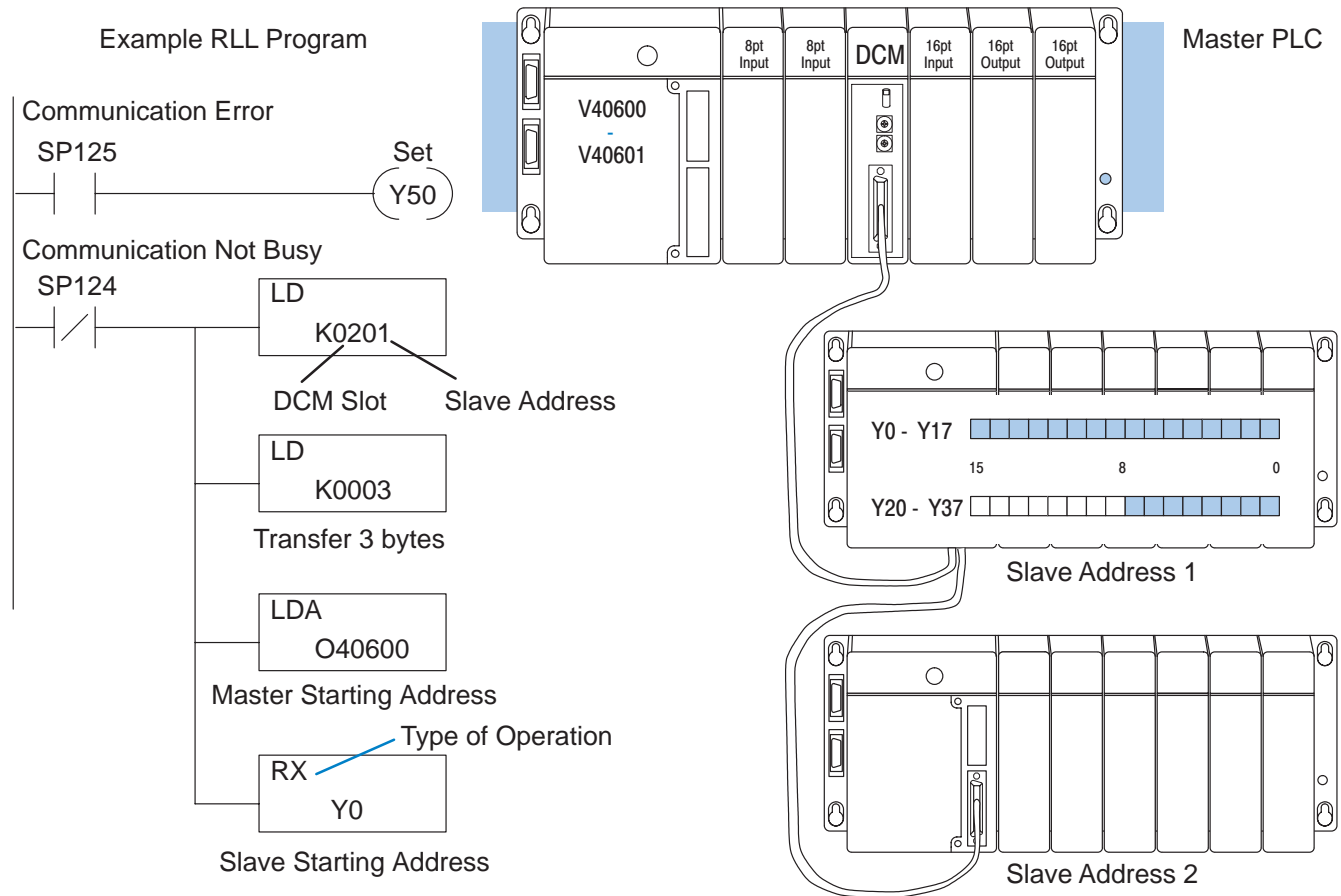

This example writes 3 bytes of data from the Master Station (starting at V40600) to Y0 – Y27 in Slave Station #1.

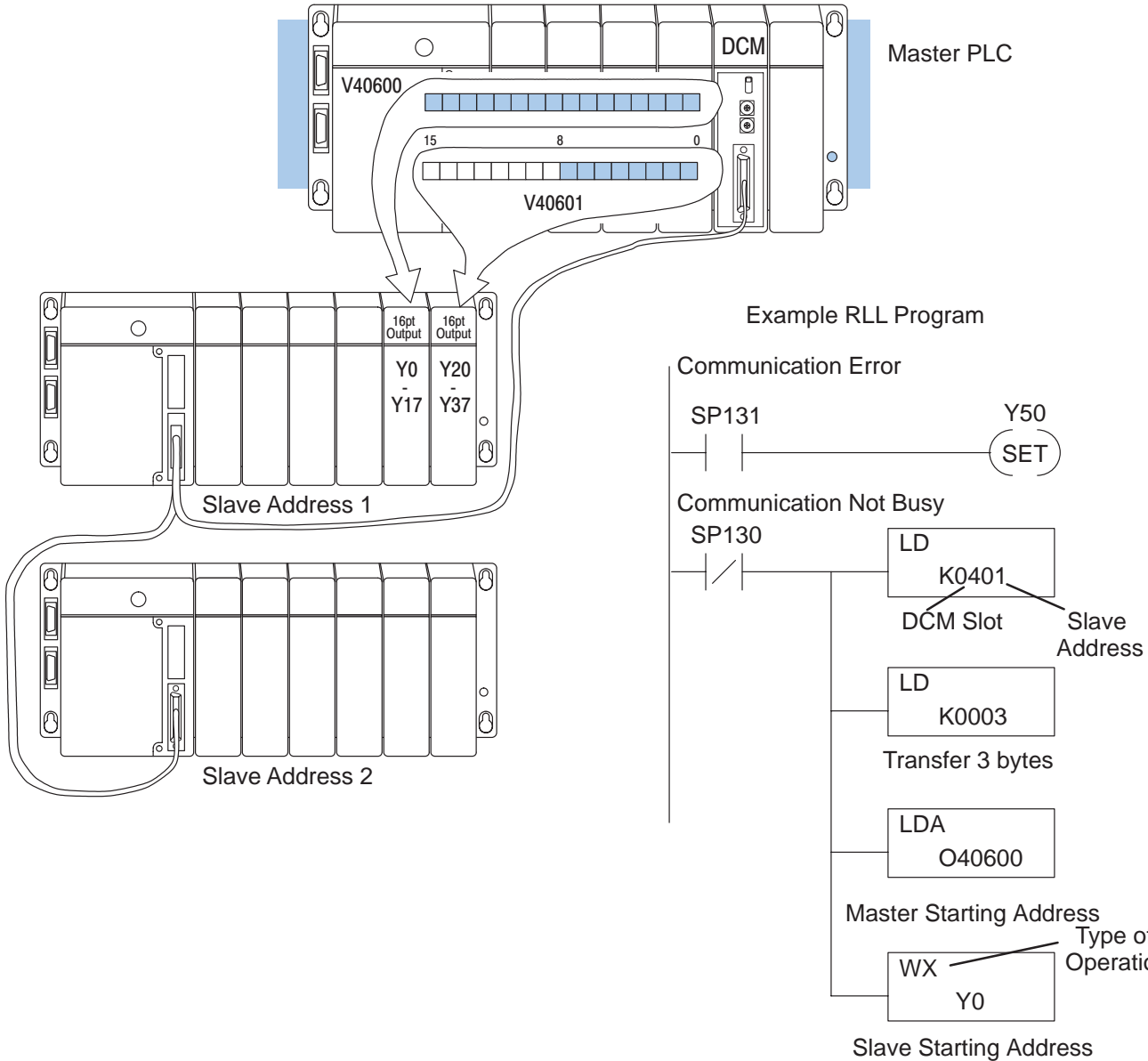

The following paragraphs explain each operation and provide some helpful hints to make your programs simple and easy to follow.

Identifying the master and slave

Location of Master and Slave

The first Load (LD) instruction identifies the slot location of the DCM master and the address of the slave station. (Remember, the slot numbers start at 0.)

The constant (K) portion of the instruction actually contains two pieces (bytes) of information. The first two digits specify the DCM master location and the second two digits specify the slave station address.

It is necessary to specify both the master slot location and slave address because you can have more than one DCM master in the base and you can have up to 90 slave stations for each master.

NOTE: The LD instruction K value is entered in decimal, but the DCM master and slave addresses are in HEX. You have to convert the HEX addresses to their decimal equivalent for this instruction. It's easy to convert from HEX to decimal.

Valid Slot Range: 0-7

Valid Slave Address: 1-90

Example:

Master Slot: 2 HEX, 2 decimal

Slave Address: 1 HEX, 1 decimal

HEX Format

0	1	2	3	4	5	6	7	8	9	A	B	C	D	E	F
										10	11	12	13	14	15

HEX 3C

$$3 \times 16 = 48 + C = 12 = 60 \text{ decimal}$$

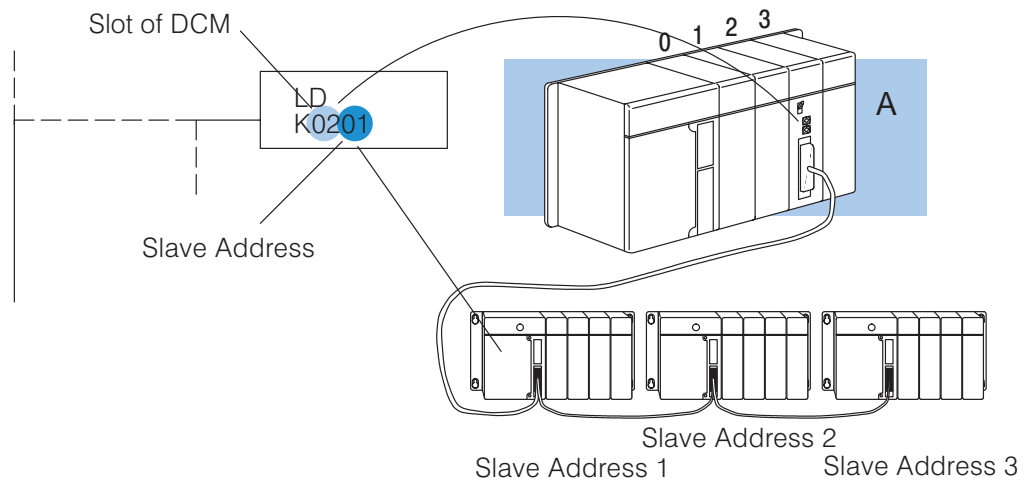

Specifying the amount of data

Number of Bytes to Transfer

The second LD instruction indicates the amount of data (in bytes) that needs to be transferred. You have to specify the amount of data in complete bytes. For example, Y0 – Y27 would be three bytes of data.

The different PLC families do not always use the same types of memory or the same byte boundaries. For example, the DL305 does not use a separate data type for input and output points.

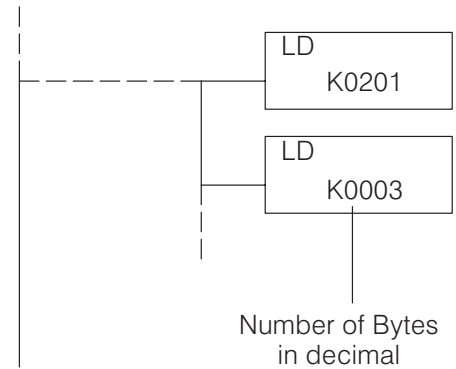

Example:
3 bytes of data to be transferred

The number of bytes specified also depends on the type of data you want to obtain. For example, the DL405 Input points can be accessed by V-memory locations or as X input locations. However, if you only want X0 – X27, you'll have to use the X input data type because the V-memory locations can only be accessed in 2-byte increments. The following table shows the byte ranges for the various types of *DirectLOGIC™* products.

DL 205 / 405 Memory	Bits per unit	Bytes
V memory	16	2
T / C current value	16	2
Inputs (X, GX, SP)	8	1
Outputs (Y, C, Stage, T/C bits)	8	1
Scratch Pad Memory	8	1
Diagnostic Status	8	1

DL305 Memory	Bits per unit	Number of bytes
Data registers	8	1
T / C accumulator	16	2
I/O, internal relays, shift register bits, T/C bits, stage bits	1	1
Scratch Pad Memory	8	2
Diagnostic Status (5 word R/W)	16	10

Designating the master station memory area

Memory Area of Master

The Load Address (LDA) instruction specifies the V memory area of the master that will be used. This is the starting address. Additional sequential locations may be used, depending on the number of bytes that are being transferred. Since all DL405 data is mapped into V memory, you can easily access the data you need.

If you are reading information from the slave station, this is the destination area, or, the area where the master will store the information.

If you are writing information to the slave station, this is the source area, or, the area where the master will obtain the information that will be transferred to the slave.

NOTE: Since V memory words are always 16 bits, you may not always use the whole word. For example, if you only specify 3 bytes and you are reading Y outputs from the slave, you will only get 24 bits of data. In this case, only the 8 least significant bits of the last word location will be modified. The remaining 8 bits are not affected.

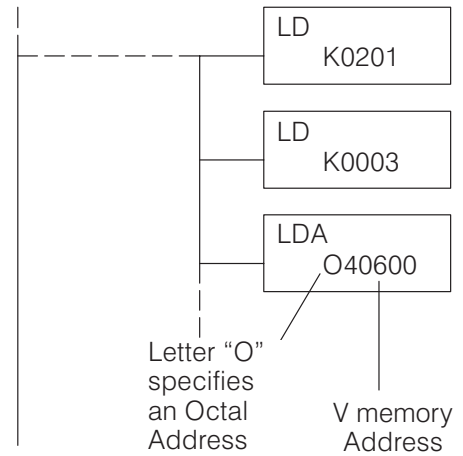

Example:

V memory location 40600 will be the starting point of the data transfer area for the master. The following locations will be used to store the data.

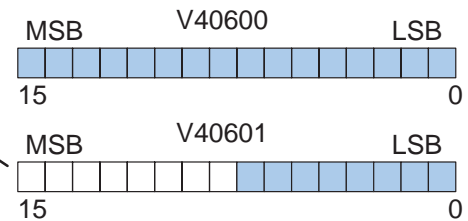

Identifying the slave station memory area

Memory Area of Slave to Read or Write

The Read Network (RX) or Write Network (WX) is the last instruction in the routine. Use the RX if you want to read data from the slave, or use the WX instruction if you want to write data to the slave.

You have to specify the data type and the starting address (in octal) for the slave. (Remember, you have to specify a data type that will work correctly with the number of bytes specified.)

If you use the RX instruction, the data will be read from the slave starting at the address specified. If you use the WX instruction, the data will be written to the slave starting at the address specified.

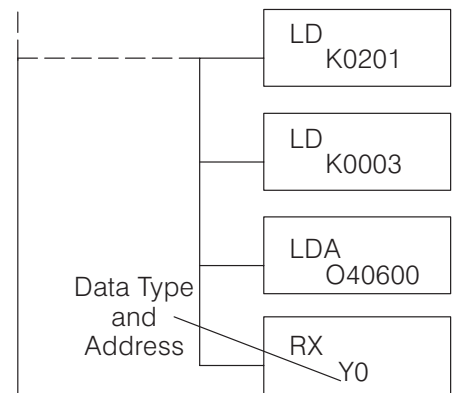

Example:
Read from slave starting at Y0.

NOTE: If you are using an RLL communications program to transfer data to or from a DL305 slave station, the data type is slightly different. For example, the DL305 I/O points are accessed with the GY data type. The *DirectNET* manual provides a listing of memory types and cross references for the DL305 family.

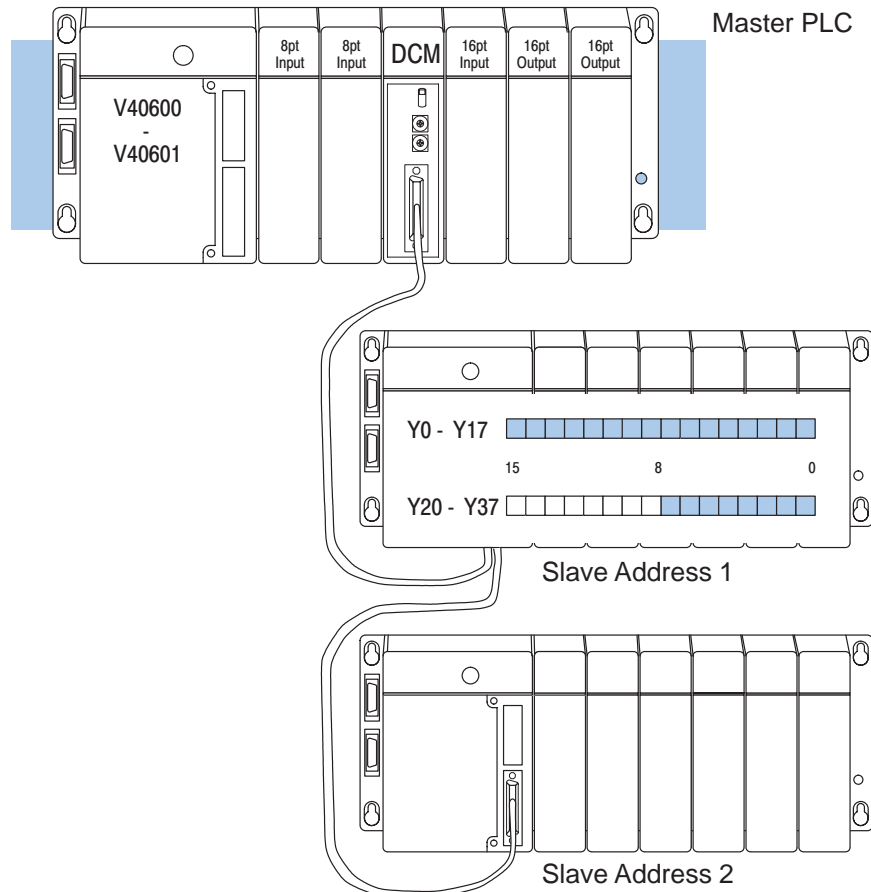

Controlling the communications

Communications Special Relays

When you execute communication with a DCM, chances are good the communication may take longer than the actual PLC scan. If the DCM is busy, you should not initiate another request until it is finished. Fortunately, there's an easy solution for this.

There are two SPs for each slot in the CPU base which are used only with the DCM. For example, slot 0 has SP120 and SP121. SP120 is the DCM Busy relay and, when turned on, indicates the DCM is busy. SP121 indicates there is a communication error for slot 0.

You should always use the DCM Busy SP in your RLL programs to ensure the DCM is ready.

The communication error SP is optional, but it's a good way to monitor the communication status in the RLL program. If you use the communication error SP, make sure you place it at the beginning of your communication routines. This is because the communication error relay is always reset (turned off) whenever an RX or WX instruction is executed.

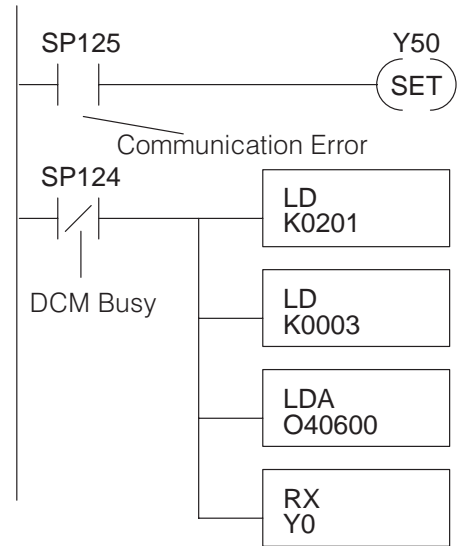

Special Purpose Communication Relays								
Communication Busy	SP120	SP122	SP124	SP126	SP130	SP132	SP134	SP136
Communication Error	SP121	SP123	SP125	SP127	SP131	SP133	SP135	SP137
I/O Slot Location	0	1	2	3	4	5	6	7

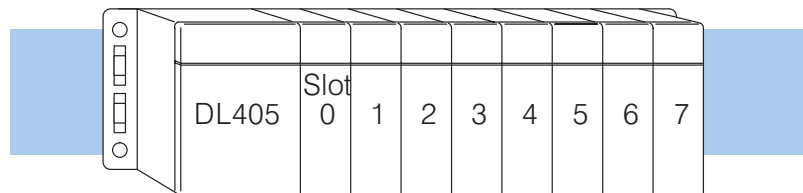

Multiple Read and Write Interlocks

If you're using multiple reads and writes in the RLL program, you have to interlock the routines to make sure all the routines are executed. If you don't use the interlocks, then the CPU will only execute the first routine. This is because the DCM can only handle one routine at a time.

In the example, once the RX instruction is executed, C0 is set. When the DCM has finished the communication task, the second routine is executed and C0 is reset.

If you're using RLL^{PLUS}, you can just put each routine in a separate program stage to ensure proper execution. In most all cases, RLL^{PLUS} is a much more efficient way to create automation program.

The **DirectNET** manual provides a master / slave example with both RLL and RLL^{PLUS} program descriptions.

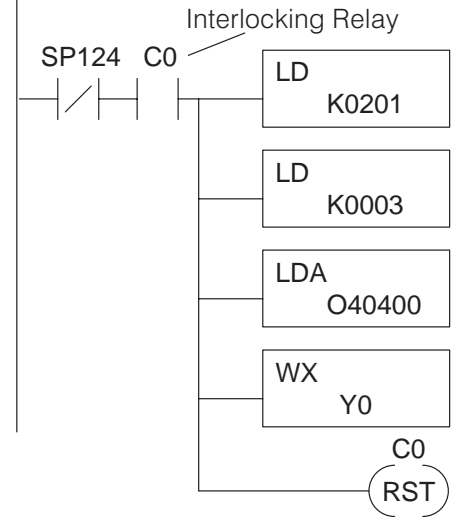
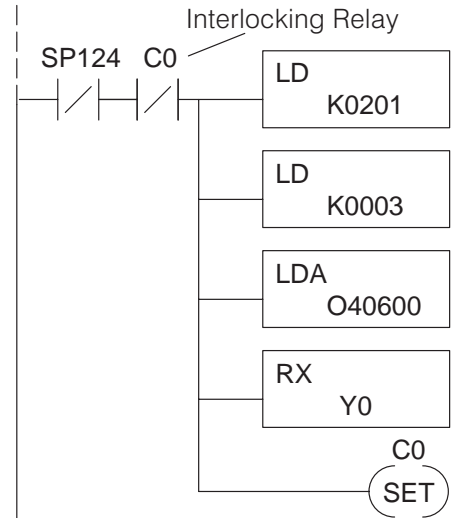

DL305 / 405 Cross Reference

If you are using a DL405 Master, you will have to make some slight changes in the way you request certain types of data. For example, the DL405 uses V-memory references instead of Register references. This section shows the cross references.

NOTE: Not all DL305 devices offer the same memory ranges. Check your DL305 User Manual to determine the ranges for your particular model.

Data Type 31: Register Access

To get to ... TMR / CTR Accumulator in a DL305	Use Reference ... in a DL405	To get to ... Register Data in a DL305	Use Reference ... in a DL405
R600	V000	R401, 400*	V100
R601	V001	R403, 402	V101
— — — —	— — — —	— — — —	— — — —
R624	V024	R777, 776	V237
R677	V077		

Two bytes of DL305 register data are returned with one DL405 V memory location.

Data Type 33: I/O Point Access

Non RLL ^{PLUS} CPUs			
To get to ... I/O Points, CRs, & Shift Registers in a DL305	Use Reference ... in a DL405	To get to ... TMR / CNT Status Bit in a DL305	Use Reference ... in a DL405
IO 000	GY000	600	GY600
IO 001	GY001	601	GY601
— — — —	— — — —	— — — —	— — — —
IO 157	GY157	677	GY677
CR160	GY160		
— — — —	— — — —		
CR 377	GY377		
IO 700	GY700		
IO 701	GY701		
— — — —	— — — —		
IO 1067	GY1067		
SR 400	GY400		
SR 401	GY401		
— — — —	— — — —		
SR 577	GY577		

RLL ^{PLUS} CPUs					
To get to ... I/O Points, CRs, & Shift Registers in a DL305	Use Ref. ... in a DL405	To get to ... Stage Status Bit in a DL305	Use Ref. ... in a DL405	To get to ... TMR / CNT Status Bit in a DL305	Use Ref. ... in a DL405
IO 000	GY000	000	GY200	600	GY600
IO 001	GY001	001	GY201	601	GY601
— — — —	— — — —	— — — —	— — — —	— — — —	— — — —
CR160	GY160	177	GY377	677	GY677
— — — —	— — — —				
CR 277	GY277				
IO 700	GY700				
IO 701	GY701				
IO 1067	GY1067				
SR 200	GY400				
SR 201	GY 401				
— — — —	— — — —				
SR 277	GY477				