

KEYPAD OPERATION AND QUICK-START

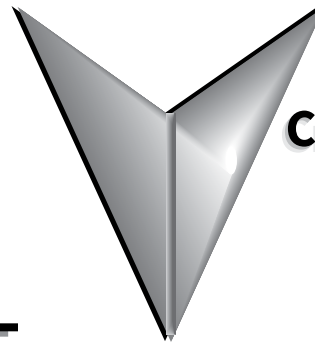

CHAPTER

3

CONTENTS OF THIS CHAPTER

<i>The DURApulse GS3 Digital Keypad</i>	<i>.3-2</i>
<i>LCD Display.</i>	<i>3-2</i>
<i>LED Indicators</i>	<i>3-2</i>
<i>Function Keys</i>	<i>3-3</i>
<i>Adjust Frequency Setpoint</i>	<i>3-3</i>
<i>Adjust PID Setpoint</i>	<i>3-3</i>
<i>Displaying the Status of the DURApulse GS3 AC Drive.</i>	<i>3-4</i>
<i>Programming the DURApulse GS3 AC Drive</i>	<i>.3-5</i>
<i>DURApulse GS3 Quickstart</i>	<i>.3-6</i>
<i>Example 1: Constant Torque (e.g. conveyors, compressors, etc.)</i>	<i>3-6</i>
<i>Example 2: Variable Torque (e.g. fans, centrifugal pumps, etc.)</i>	<i>.3-10</i>
<i>Auto-Tune Procedure</i>	<i>3-14</i>
<i>Auto-Tune Instructions</i>	<i>3-15</i>
<i>Copy Keypad Function</i>	<i>3-16</i>
<i>Enable Copy Keypad Function</i>	<i>.3-16</i>
<i>Write Parameter Settings to Keypad</i>	<i>.3-17</i>
<i>Write Parameter Settings to Drive</i>	<i>.3-18</i>

THE DURAPULSE GS3 DIGITAL KEYPAD

The digital keypad includes a 2-line x 16-character LCD display, 5 status LED Indicators, and 9 function keys. The diagram below shows all of the features of the digital keypad and an overview of their functions.

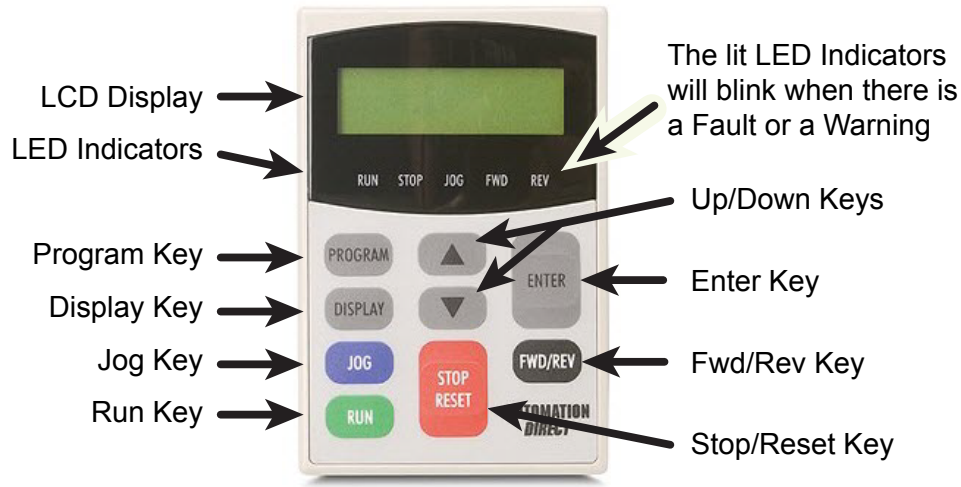

LCD DISPLAY

The LCD Display shows the operation values and parameter settings of the AC drive.

LED INDICATORS

The combination of solid RUN and flashing STOP LEDs indicates that the drive has an active RUN command, but has a zero speed reference.

RUN	The RUN LED indicates the AC drive is in Run Mode.
STOP	The STOP LED indicates the AC drive is <u>not</u> in Run Mode.
FWD	The FWD LED indicates the AC drive is running the motor in the forward direction.
REV	The REV LED indicates the AC drive is running the motor in the reverse direction.
JOG	The JOG LED indicates the AC drive is in the Jog Mode.



If the STOP key on the keypad is active and the keypad is removed, the drive will stop.

FUNCTION KEYS

PROGRAM KEY

Pressing the PROGRAM key will display the parameter groups. Use the UP/DOWN or PROGRAM keys to cycle through the parameter groups. The LCD display will show which parameter group is currently selected.

DISPLAY KEY

Pressing the DISPLAY key on the keypad repeatedly will cycle through the status messages on the AC drive.

FWD/REV KEY

Pressing the FWD/REV key changes the direction in which the motor operates.

RUN

Pressing the RUN key starts the AC drive operation. This key has no function if the AC drive is controlled by the external control terminals.

UP/DOWN KEYS

The UP/DOWN keys are used to scroll through the parameter groups, the various parameters in each group and also change the parameter settings in single-unit increments. To quickly run through the range of settings, press and hold the UP or DOWN key.

ENTER KEY

Press the ENTER key to view parameters and store parameter settings.

STOP/RESET KEY

Used to stop AC drive operation. If the AC drive has stopped due to a fault, clear the fault first, then press this key to reset the AC drive.

JOG KEY

Pressing the JOG key controls the jog function.



After a one (1) minute key inactivity, the keypad LCD display will automatically revert to the display mode and display the user defined display function selected in parameter P8.00.

ADJUST FREQUENCY SETPOINT

If the UP and DOWN keys are pressed when the LCD is in DISPLAY mode and the AC drive frequency is being controlled by the keypad (P4.00=1), then the keypad will display the frequency setpoint and have the ability to adjust the frequency setpoint with the UP/DOWN keys accordingly. The frequency setpoint will be stored even if the drive is powered off.

ADJUST PID SETPOINT

The ability to adjust the PID setpoint with the UP and DOWN keys will be true if parameter P7.00 is set to a value of 01, 02, 03, or 04, parameter P7.02 = 00 and the LCD display shows the PID setpoint.

DISPLAYING THE STATUS OF THE DURAPULSE GS3 AC DRIVE

Press the DISPLAY key on the keypad repeatedly to cycle through the status messages on the AC drive. The diagram below shows the order of the status messages as you cycle through them and shows the definition of the status messages. The status of the AC drive can be shown in RUN or STOP mode.

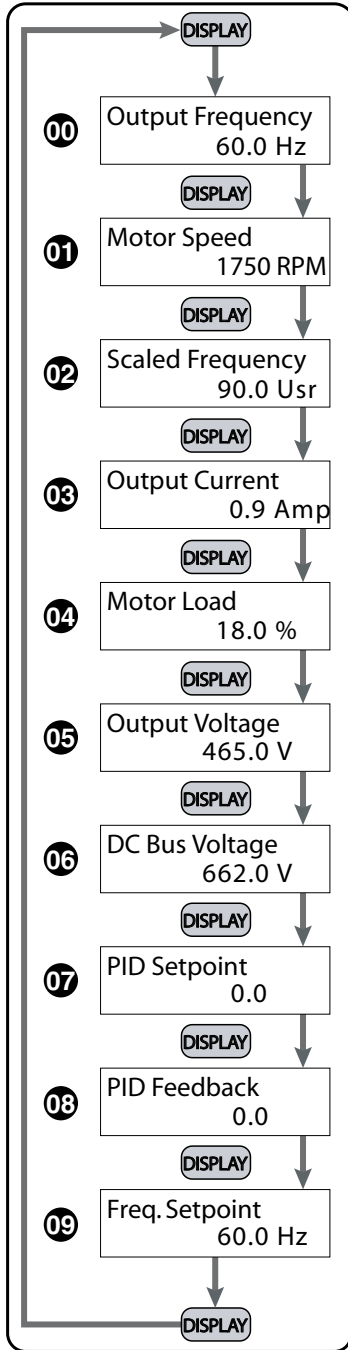

- 00 Actual Operating Frequency**
Displays the actual operating frequency present at the T1, T2, and T3 terminals. *Example: 60.0Hz*
- 01 RPM**
Displays the present estimated speed of the motor.
Example: 1750 RPM
- 02 Scaled Frequency**
Displays the result of output frequency x parameter P8.01.
Example: 60Hz x 1.5 = 90.0
- 03 Amps**
Displays the output current present at the T1, T2, and T3 terminals. *Example: 0.9A*
- 04 % Motor Load**
Displays the amount of load on the AC drive.
Example: (Output Current v Drive Rated Current) x 100
- 05 Output Voltage**
Displays the output voltage present at the T1, T2, and T3 terminals. *Example: 465V*
- 06 DC Bus Voltage**
Displays the DC Bus Voltage. *Example: 662 VDC*
- 07 PID Setpoint**
Displays the PID setpoint. *Note: It is possible to change the PID setpoint with the ▲ and ▼ keys when the PID setpoint value is displayed on the keypad. The PID function (P7.00) must be enabled, and the PID Setpoint source (P7.02) must be set to keypad (00).*
- 08 PID Feedback Signal (PV)**
Displays the PID feed-back signal.
- 09 Frequency Setpoint**
Displays the frequency setting of the AC drive. *Example: 60.0Hz*

PROGRAMMING THE DURAPULSE GS3 AC DRIVE

The *DURAPULSE* GS3 AC Drive parameters are organized into eleven (11) different groups according to their functions, plus a special “Copy Keypad” function for storing up to four (4) different sets of program parameters into the keypad. The illustration below shows you how to navigate through the parameter groups and parameter settings. For a complete list of parameters, see Chapter 4.

- 1) Press the PROGRAM key and then use the UP/DOWN or PROGRAM keys to cycle through the parameter groups. The LCD display will show the parameter group that is currently selected.
- 2) Press the ENTER key to display the various parameters for the selected group and use the UP/DOWN keys to view each one.
- 3) (same as #2)
- 4) When the desired parameter is shown, press the ENTER key to select.
- 5) Use the UP/DOWN keys to cycle through the available settings.
- 6) Press the ENTER key to select the setting. The phrase “Value Accepted” will be displayed for a moment to show that the parameter value has been changed.
- 7) After the parameter value has been set, the LCD display will cycle to the next parameter in the selected group.

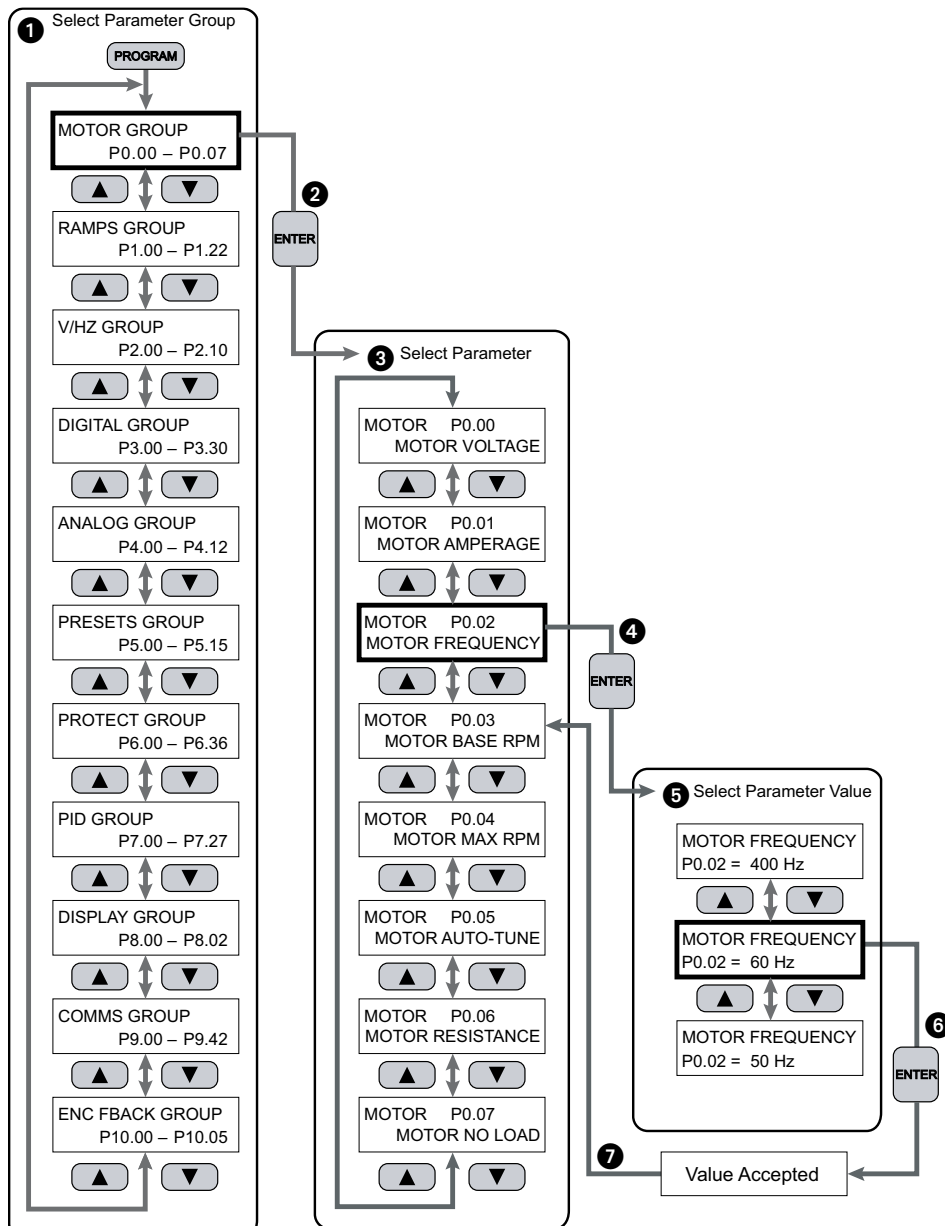

DURAPULSE GS3 QUICKSTART

The following examples will help you quickly set up your DURApulse AC Drive for two common applications. The first example applies to an application that requires constant torque, and the second example requires variable torque in its application.



For a complete list and description of the parameters for the DURApulse AC drives, see Chapter 4.

EXAMPLE 1: CONSTANT TORQUE (E.G. CONVEYORS, COMPRESSORS, ETC.)

In this example, the AC drive needs to operate a motor that is connected to a conveyor. In order to decide which parameters need modifications, we will make a list of the needs for the application.

APPLICATION NEEDS

- The AC drive must control a 460V, 1hp inverter duty motor. We will use a model GS3-41P0 AC drive for this application. An example of the motor nameplate is shown below.

INVERTER DUTY MOTOR							
HP	1	VOLTS	460	PHASE	3	TYPE	P
RPM	1725	AMPS	2.6	HZ	60	SF	1.15
DESIGN B		AMB	40°C		INSUL CLASS		F
DUTY	CONT	ENCL	TEFC		CODE		K

- The maximum speed for the motor is 2000 rpm.
- The motor should accelerate to maximum speed in 5 seconds.
- The motor should decelerate from maximum speed in 5 seconds. (Applications with high starting torque requirements and/or high inertia loads may require optional braking resistors.)
- The motor will require a high torque when starting.
- The operation of the motor (start, stop, etc.) will be controlled by remote control terminals. All keys on the DURAPULSE GS3 keypad should be disabled.
- The frequency of the AC drive will be determined by remote potentiometer that has a 0 to +10V signal.
- The display of the AC drive should default to the motor speed (rpm) when running.

PARAMETER SETUP

In order to meet the needs of this application, the parameters should be set as follows:

P0.00 Motor Nameplate Voltage **Setting: 460**
Settings: 230V series: 200/208/220/230/240 Default Setting: 240
 460V series: 380/400/415/440/460/480 Default Setting: 480

This parameter setting is determined by the motor nameplate.

P0.01 Motor Nameplate AMPS **Setting: 2.6**
Range: Drive Rated Amps x 0.4 to Drive Rated Amps x 1.0 Default Setting: Drive Rating (A)

This parameter setting is determined by the motor nameplate.

P0.02 Motor Base Frequency **Setting: 60**
Range: 50/60/400 Default Setting: Drive Rating 60

This parameter setting is determined by the motor nameplate.

P0.03 Motor Base RPM **Setting: 1725**
Range: 375 to 24,000 RPM Default Setting: 1750

This parameter setting is determined by the motor nameplate.

P0.04 Motor Maximum RPM **Setting: 2000**
Range: P0.03 to 24,000 RPM Default Setting: P0.03

This parameter setting is determined by the needs of the application.



WARNING: THE MOTOR MAXIMUM RPM PARAMETER (P0.04) SHOULD NEVER EXCEED THE MAXIMUM RPM RATING FOR THE MOTOR THAT YOU ARE USING. IF THIS INFORMATION IS NOT READILY AVAILABLE, CONSULT YOUR MOTOR MANUFACTURER.

P1.00 Stop Methods **Setting: 00**
Settings: 00 Ramp to Stop Default Setting: 00
 01 Coast to stop

The application requires that this parameter be set to Ramp to Stop because the motor needs to stop under power. (If the AC drive is set for Coast to Stop, the AC drive will ignore the Deceleration Time setting.)



WARNING: IF THE STOP METHOD FOR THE DURAPULSE GS3 AC DRIVE IS SET FOR COAST TO STOP, THE AC DRIVE WILL IGNORE THE (P1.02) SETTING FOR DECELERATION TIME.

P1.01 Acceleration Time **Setting: 5.0**
Range: 0.1 to 600 sec *Default Setting:* 10

The motor should accelerate from 0 RPM to Maximum Motor RPM (P0.04) in 5 seconds.

P1.02 Deceleration Time **Setting: 5.0**
Range: 0.1 to 600 sec *Default Setting:* 30

The motor should decelerate from 2000 rpm; Maximum Motor RPM (P0.04) to 0 RPM in 5 seconds.

P2.00 Volts/Hertz Settings **Setting: 01**
Settings: 00 - General Purpose *Default Setting:* 00
 01 - High Starting Torque
 02 - Fans and Pumps
 03 - Custom

The DURAPULSE GS3 AC drive has some predefined torque settings that meet the needs of most applications. A custom setting is available if needed. In this particular example, the application requires a high starting torque.

P3.00 Source of Operation Command **Setting: 02**
Settings: *Default Setting:* 00

- 00 - Operation Determined by Digital Keypad.
- 01 - Operation determined by external control terminals. Keypad STOP is enabled.
- 02 - Operation determined by external control terminals. Keypad STOP is disabled.
- 03 - Operation determined by RS-485 interface. Keypad STOP is enabled.
- 04 - Operation determined by RS-485 interface. Keypad STOP is disabled.

The AC drive operation will be determined by external control terminals, and the keypad stop will be disabled.



If parameter P3.00 = 00, 01, or 03, enabling the keypad STOP key, the drive will stop if the keypad is removed from the drive.

P4.00 Source of Frequency Command

Setting: 02

- Settings: 01 - Frequency determined by digital keypad up/down
 02* - Frequency determined by 0 to +10V input on AI1 terminal
 03 - Frequency determined by 4 to 20 mA input on AI2 terminal
 04 - Frequency determined by 0 to 20 mA input on AI2 terminal
 05 - Frequency determined by RS-485 communication interface
 06 - Frequency determined by -10V~+10V input on AI3 terminal

Default Setting: 01

* In order to set P4.00 = 02, you must first change the value of P4.13 to some value other than two (02) in order to avoid the "Error: Duplicate Function" error message. (P4.13 default value is 02)



When configured for "Frequency determined by digital keypad Up/Down, the drive will reset the commanded frequency to zero hertz on a power cycle. This happens only if the drive faults when it powers down (if its running when it loses power). If the drive is stopped when it loses power (and doesn't trigger a Low Voltage Fault), the drive will retain the last set speed when powered back up.

P6.00 Electronic Thermal Overload Relay

Setting: 00

- Settings: 00 - Constant Torque (inverter/vector duty motor)
 01 - Variable Torque (fan-cooled standard motor)
 02 - Inactive

Default Setting: 00

This function setting 00 is the standard overload protection curve used to protect inverter/vector duty motors.

P8.00 User Defined Display Function

Setting: 01

- Settings: 00 - Output Frequency (Hz)
 01 - Motor Speed (RPM)
 02 - Scaled Frequency
 03 - Output Current (A)
 04 - Motor Load (%)
 05 - Output Voltage(V)
 06 - DC Bus Voltage (V)
 07 - PID Setpoint
 08 - PID Feedback (PV)
 09 - Frequency Setpoint

Default Setting: 00

The AC drive display will default to motor speed (rpm) when running.

EXAMPLE 2: VARIABLE TORQUE (E.G. FANS, CENTRIFUGAL PUMPS, ETC.)

In this example, the AC drive needs to operate a motor that is connected to a centrifugal pump. As in Example 1, we will make a list of the needs for the application in order to decide which parameters need modifications.

APPLICATION NEEDS

- The AC drive must control a 208V, 3hp fan-cooled standard duty motor. The AC drive model we will be using for this application is a GS3-23P0. An example of the motor nameplate is shown below.

STANDARD DUTY MOTOR							
HP	3	VOLTS	208	PHASE	3	TYPE	P
RPM	3525	AMPS	9.2	HZ	60	SF	1.15
DESIGN B		AMB	40°C		INSUL CLASS		F
DUTY	CONT	ENCL	TEFC	CODE		K	

- The maximum speed for the motor is 3600 rpm.
- The motor should accelerate to maximum speed in 20 seconds.
- The motor should coast to stop when operation is terminated.
- The motor will be turning a centrifugal pump.
- The operation of the motor (start, stop, etc.) will be controlled by the DURAPULSE GS3 digital keypad.
- The frequency of the AC drive will be determined by the DURAPULSE GS3 keypad potentiometer.
- The display of the AC drive should default to output current (A) when running.

PARAMETER SETUP

In order to meet the needs of this application, the parameters should be set as follows:

P0.00	Motor Nameplate Voltage	Setting: 208
	<i>Settings:</i> 230V series: 200/208/220/230/240	<i>Default Setting:</i> 240
	460V series: 380/400/415/440/460/480	<i>Default Setting:</i> 480

This parameter setting is determined by the motor nameplate.

P0.01	Motor Nameplate AMPS	Setting: 9.2
	<i>Range:</i> Drive Rated Amps x 0.4 to Drive Rated Amps x 1.0	<i>Default Setting:</i> Drive Rating (A)

This parameter setting is determined by the motor nameplate.

P0.02 Motor Base Frequency **Setting: 60**
Range: 50/60/400 *Default Setting:* Drive Rating 60

This parameter setting is determined by the motor nameplate.

P0.03 Motor Base RPM **Setting: 3525**
Range: 375 to 24,000 RPM *Default Setting:* 1750

This parameter setting is determined by the motor nameplate.

P0.04 Motor Maximum RPM **Setting: 3600**
Range: P0.03 to 24,000 RPM *Default Setting:* P0.03

This parameter setting is determined by the needs of the application.



WARNING: THE MOTOR MAXIMUM RPM PARAMETER (P0.04) SHOULD NEVER EXCEED THE MAXIMUM RPM RATING FOR THE MOTOR THAT YOU ARE USING. IF THIS INFORMATION IS NOT READILY AVAILABLE, CONSULT YOUR MOTOR MANUFACTURER.

P1.00 Stop Methods **Setting: 01**
Settings: 00 Ramp to Stop *Default Setting:* 00
 01 Coast to stop

The application requires that this parameter be set to Coast to Stop.



WARNING: IF THE STOP METHOD FOR THE DURAPULSE GS3 AC DRIVE IS SET FOR COAST TO STOP, THE AC DRIVE WILL IGNORE THE (P1.02) SETTING FOR DECELERATION TIME.

P1.01 Acceleration Time **Setting: 20.0**
Range: 0.1 to 600 sec *Default Setting:* 10

The motor should accelerate from 0 RPM to Maximum Motor RPM (P0.04) in 20 seconds.

P2.00 Volts/Hertz Settings**Setting: 02**

Settings: 00 - General Purpose
01 - High Starting Torque
02 - Fans and Pumps
03 - Custom

Default Setting: 00

The DURAPULSE GS3 AC drive has some predefined torque settings that meet the needs of most applications. A custom setting is available if needed. In this example, the motor will be running a pump.



In some applications it is perfectly acceptable to leave this parameter set for "00" - General Purpose.

P3.00 Source of Operation Command**Setting: 00**

Settings:
00 - Operation Determined by Digital Keypad.
01 - Operation determined by external control terminals. Keypad STOP is enabled.
02 - Operation determined by external control terminals. Keypad STOP is disabled.
03 - Operation determined by RS-485 interface. Keypad STOP is enabled.
04 - Operation determined by RS-485 interface. Keypad STOP is disabled.

Default Setting: 00

The AC drive operation will be determined by the Digital Keypad.



If parameter P3.00 = 00, 01, or 03, enabling the keypad STOP key, the drive will stop if the keypad is removed from the drive.

P4.00 Source of Frequency Command

Setting: 00

- Settings: 01 - Frequency determined by digital keypad up/down
 02* - Frequency determined by 0 to +10V input on AI1 terminal
 03 - Frequency determined by 4 to 20 mA input on AI2 terminal
 04 - Frequency determined by 0 to 20 mA input on AI2 terminal
 05 - Frequency determined by RS-485 communication interface
 06 - Frequency determined by -10V~+10V input on AI3 terminal

Default Setting: 01

* In order to set P4.00 = 02, you must first change the value of P4.13 to some value other than two (02) in order to avoid the "Error: Duplicate Function" error message. (P4.13 default value is 02)



When configured for "Frequency determined by digital keypad Up/Down, the drive will reset the commanded frequency to zero hertz on a power cycle. This happens only if the drive faults when it powers down (if its running when it loses power). If the drive is stopped when it loses power (and doesn't trigger a Low Voltage Fault), the drive will retain the last set speed when powered back up.

P6.00 Electronic Thermal Overload Relay

Setting: 01

- Settings: 00 - Constant Torque (inverter/vector duty motor)
 01 - Variable Torque (fan-cooled standard motor)
 02 - Inactive

Default Setting: 00

This function setting 01 is used to derate the AC drive output current overload protection to protect a fan-cooled standard motor running at low speeds.

P8.00 User Defined Display Function

Setting: 03

- Settings: 00 - Output Frequency (Hz)
 01 - Motor Speed (RPM)
 02 - Scaled Frequency
 03 - Output Current (A)
 04 - Motor Load (%)
 05 - Output Voltage(V)
 06 - DC Bus Voltage (V)
 07 - PID Setpoint
 08 - PID Feedback (PV)
 09 - Frequency Setpoint

Default Setting: 00

The AC drive display will default to indicate Output Current (A) when running.



For a complete list and description of the parameters for the DURAPULSE GS3 AC drives, see Chapter 4.

AUTO-TUNE PROCEDURE

Auto-tuning is required only for Sensorless Vector Control Modes (P2.10 = 02, 03, 05).



WARNING: THE MOTOR WILL ROTATE WHEN EXECUTING THE AUTO-TUNING PROCEDURE. IT IS ALSO VERY IMPORTANT THAT NO LOAD BE CONNECTED TO THE MOTOR OUTPUT SHAFT AT THE TIME THE AUTO-TUNE PROCEDURE IS PERFORMED.

The DURAPULSE GS3 AC drive is capable of performing an auto-tune procedure when a motor is connected to the AC drive. It is also very important for safety and functional reasons that *no load* be physically connected to the motor output shaft *during auto-tuning*. The auto-tune will begin when the RUN key is pressed on the AC drive keypad. To enable the Auto-Tune procedure, do the following:

- 8) Press the PROGRAM key repeatedly until the MOTOR GROUP, P0.00–P0.07, is displayed on the keypad LCD display.
- 9) Press the ENTER key to display the various parameters for this group.
- 10) Use the UP/DOWN keys to display parameter P0.05, MOTOR AUTO-TUNE.
- 11) Press the ENTER key to display the current value for this parameter.
- 12) Use the UP/DOWN keys to change the value in this parameter to either a “1” to have the drive determine only the motor line to line resistance R1 (P0.06) or “2” to determine R1 (P0.06) and motor no-load current (P0.07).
- 13) Press the ENTER key to accept this value and enable the AUTO-TUNE function. The LCD display will indicate with “MOTOR AUTO-TUNE, <STOP> TO CANCEL” message for 3 seconds.
- 14) Proceed to the next page for steps to initiate the auto-tune procedure.

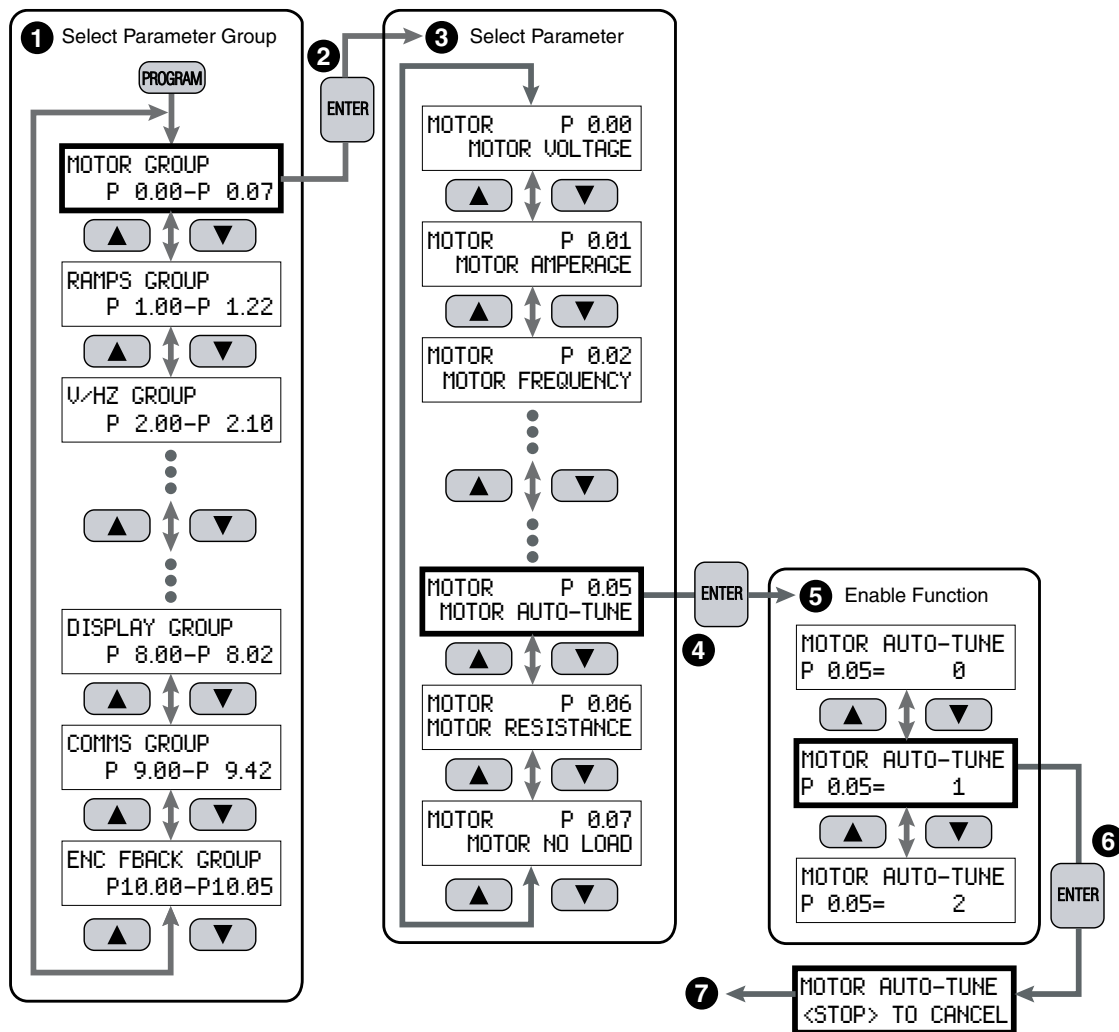

The "MOTOR AUTO-TUNE" display text flashes during this step.



It is not necessary to set up the encoder and control mode before performing the auto-tuning function. (Auto-tuning is required only for the sensorless vector control modes.)



*Do NOT set auto-tuning without a motor connected to the drive.
Do NOT set auto-tuning with any mechanical load connected to the motor output shaft.*



P3.00 must be set to zero (0) before auto-tuning; failure to do so will result in an ---ERR--- indication.

AUTO-TUNE INSTRUCTIONS

If the drive is set to auto-tune with no motor connected, the drive will go into an infinite auto-tune loop without access to the parameter groups. To correct this situation, simply power down the unit, connect the motor, complete auto-tuning (even if incorrect), reset factory default (9.08 = 99), and then start over.

- 1) Make sure all wiring is correctly connected to the AC drive and motor.
- 2) Make sure there is no load connected to the motor's output shaft, including any belts or gear boxes.
- 3) Program parameters P0.00, P0.01, P0.02, P0.03 and P0.04 with the correct values for the motor being used.
- 4) After enabling the Auto-Tune parameter P0.05 as shown on the previous page for either a "1" to have the AC drive determine only the motor line to line resistance R1 (P0.06), or a "2" to determine R1 (P0.06) and the motor's no-load current (P0.07), the message MOTOR AUTO-TUNE (flashing), <STOP> TO CANCEL will appear on the keypad LCD display for a 3 second period. If the STOP key is pressed during this time, the Auto-Tune procedure will terminate, the value in parameter P0.05 will reset to "0" and the LCD display will return to the display mode.
- 5) After the confirmation message is shown, (the AC drive is ready to perform an Auto-Tune), the keypad LCD will display the message PRESS <RUN>, TO CONTINUE for 60 seconds. Once the RUN key is pressed, the display will show DETECTING MOTOR (flashing), <STOP> TO CANCEL. If the STOP key is pressed, the Auto-Tune procedure will terminate, the keypad LCD display will show either a "R1 Detect Error" or "No Load Error" warning message, and the value in parameter P0.05 will reset to "0." Use the STOP/RESET key to clear the warning message and return the drive to the display mode. Then repeat the procedure.
- 6) The Auto-Tune procedure will take approximately 15 seconds to execute, plus the acceleration and deceleration times in parameters P1.01 and P1.02. (The greater the horsepower of the AC drive and motor, the more acceleration and deceleration time will be required.)
- 7) Upon completion of the Auto-Tune procedure, the display will show the message TUNING COMPLETE, PRESS <ENTER>. At this time, the determined values for parameters P0.06 and P0.07 will be filled in automatically. Please check these parameters to make sure a value was determined. If no value was determined, then repeat the procedure.
- 8) If the STOP/RESET key on the keypad is pressed during auto-tuning, or if the RUN key is not pressed within 60 seconds once the message PRESS <RUN>, TO CONTINUE is displayed, the Auto-Tune procedure will terminate and the value in parameter P0.05 will reset to "0." The DURAPULSE GS3 AC drive will return to the normal display mode.

COPY KEYPAD FUNCTION

The COPY KEYPAD function has the ability to permanently store up to four (4) different program parameter settings within the keypad device. The stored parameter settings can be for any of the DURApulse AC Drives. This allows the parameter settings to be backed-up and readily available for either duplicating the same multiple AC drives or for maintenance use if a drive needs to be replaced.



It is recommended that once the application has been programmed, the parameter settings be backed-up in the keypad for future use and maintenance.

ENABLE COPY KEYPAD FUNCTION

- 1) Press the PROGRAM key repeatedly until the COMMS GROUP, P9.00 – P9.42, is displayed on the keypad LCD display.
- 2) Press the ENTER key to display the various parameters for this group.
- 3) Use the UP/DOWN keys to display parameter P9.40, the COPY KEYPAD function.
- 4) Press the ENTER key to display the current value for this parameter.
- 5) Use the UP/DOWN keys to change the value in this parameter to a “1.” A value of “1” is used to enable the COPY KEYPAD function.
- 6) Press the ENTER key to accept this value and enable the COPY KEYPAD function. The LCD display will indicate “Value Accepted” for a moment.
- 7) The LCD display will automatically increment to the next parameter in the group.

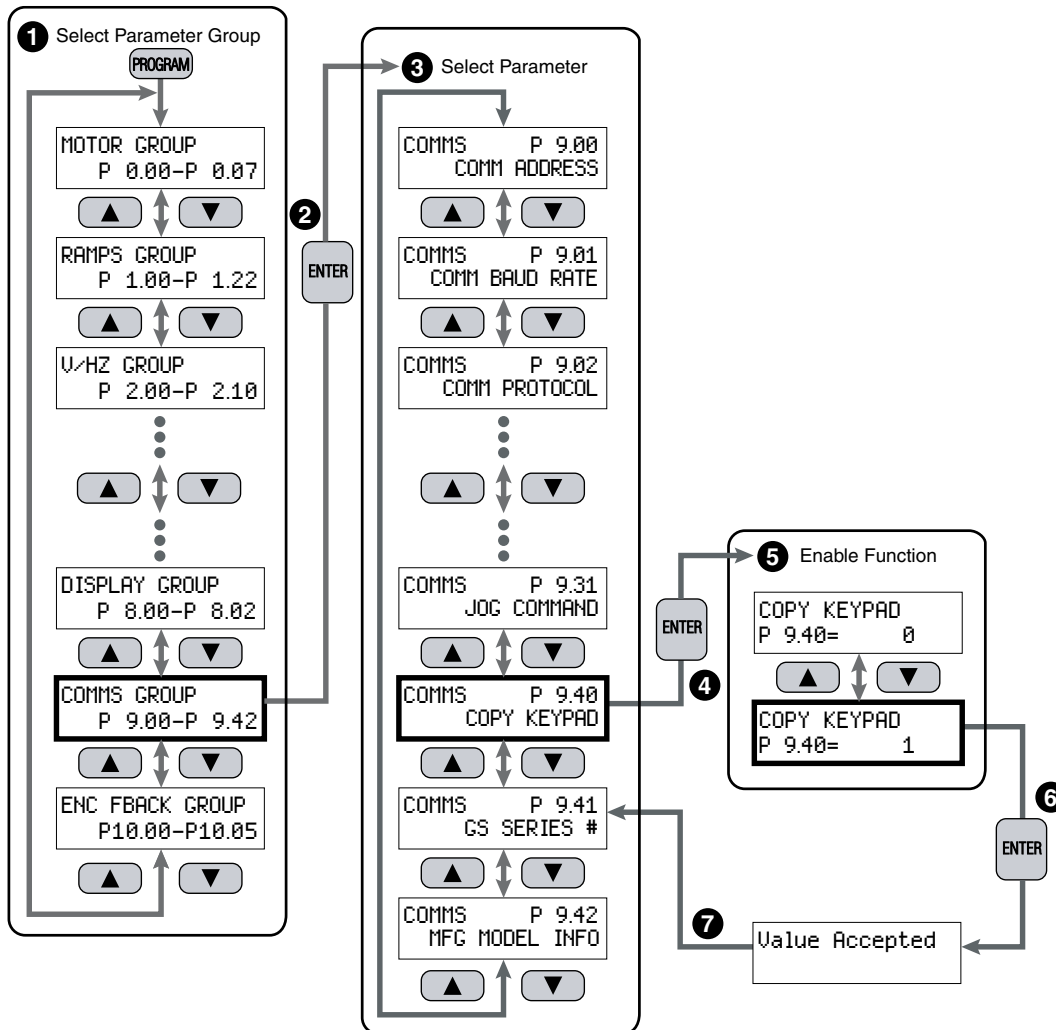

WRITE PARAMETER SETTINGS TO KEYPAD



WARNING: DO NOT REMOVE THE KEYPAD DURING TRANSFER OF PROGRAM PARAMETER SETTINGS TO OR FROM THE AC DRIVE.

- 1) After P9.40 COPY KEYPAD is enabled, the LCD display will show an additional group called COPY KEYPD GROUP. Press the PROGRAM key and then the UP/DOWN or PROGRAM keys until this new group is displayed.
- 2) Press the ENTER key to display the copy mode selections.
- 3) Select the WRITE TO KEYPAD mode using the UP/DOWN keys.
- 4) Press the ENTER key to display the four (4) available program numbers to write from the AC drive to the keypad. The program name will automatically be named the part number of the AC drive, for example: GS3-22P0.
- 5) Use the UP/DOWN keys to select the desired program number; PGM1 thru PGM4 and press the ENTER key.
- 6) (same as #5)
- 7) Use the UP/DOWN keys to select “Yes” to confirm and press the ENTER key.
- 8) (same as #7)
- 9) The LCD display will show the message “Drive => Keypad, Loading...” while the parameters are being copied and return to the program selection when finished.
(Does not restore P9.40 back to Disable Copy Keypad Function.)

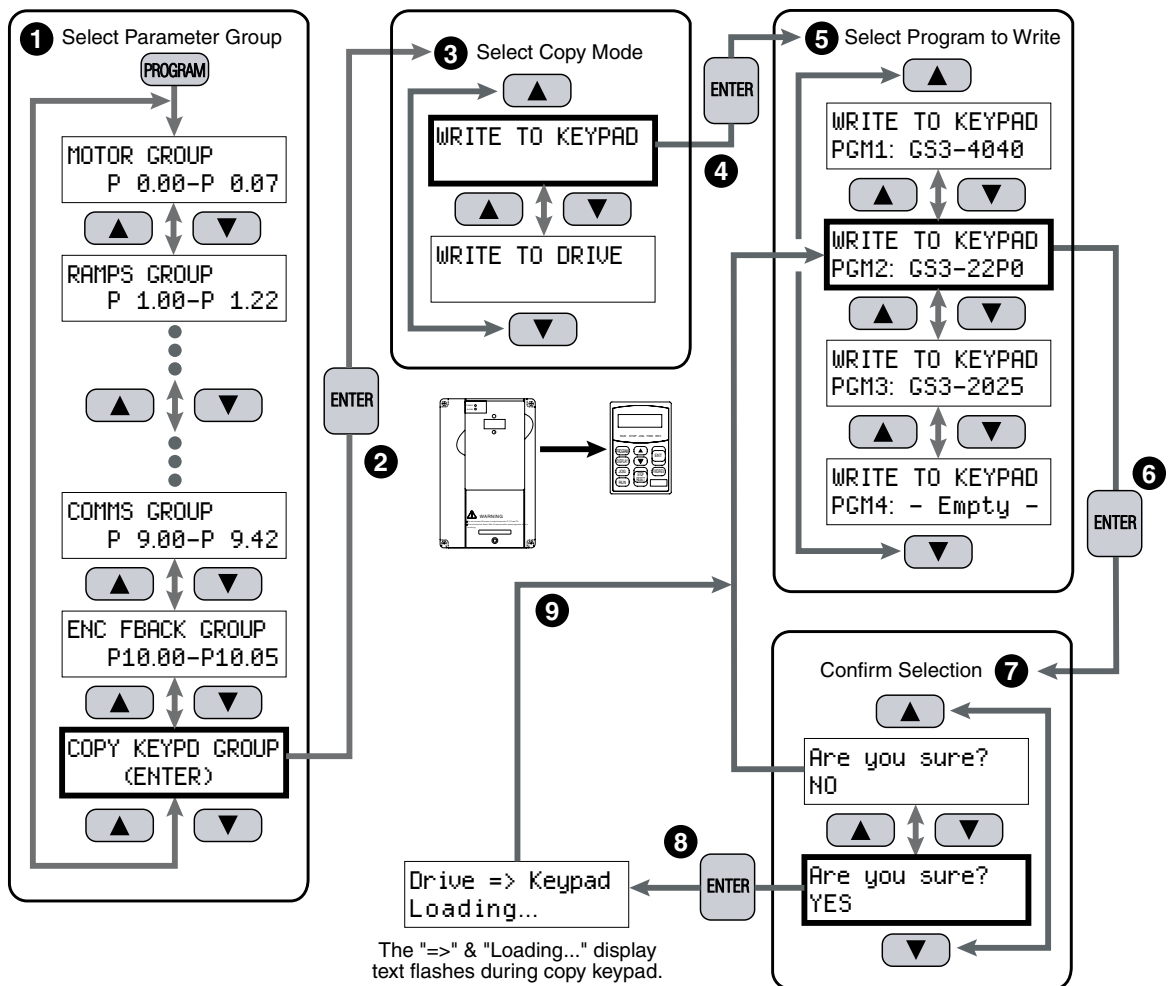

WRITE PARAMETER SETTINGS TO DRIVE



WARNING: DO NOT REMOVE THE KEYPAD DURING TRANSFER OF PROGRAM PARAMETER SETTINGS TO OR FROM THE AC DRIVE.

- 1) After the COPY KEYPAD parameter is enabled, the LCD display will show an additional group called COPY KEYPD GROUP. Press the PROGRAM key and then the UP/DOWN or PROGRAM keys until this new group is displayed.
- 2) Press the ENTER key to display the copy mode selections.
- 3) Select the WRITE TO DRIVE mode using the UP/DOWN keys.
- 4) Press the ENTER key to display the four (4) available program numbers to write from the keypad to the AC drive. The program name must match the part number of the AC drive being programmed; for example: GS3-2025.
- 5) Use the UP/DOWN keys to select the desired program number; PGM1 thru PGM4 and press the ENTER key.
- 6) (same as #5)
- 7) Use the UP/DOWN keys to select “Yes” to confirm and press the ENTER key.
- 8) (same as #7)
- 9) The LCD display will show the message “Keypad => Drive, Loading...” while the parameters are being copied and return to the program selection when finished.

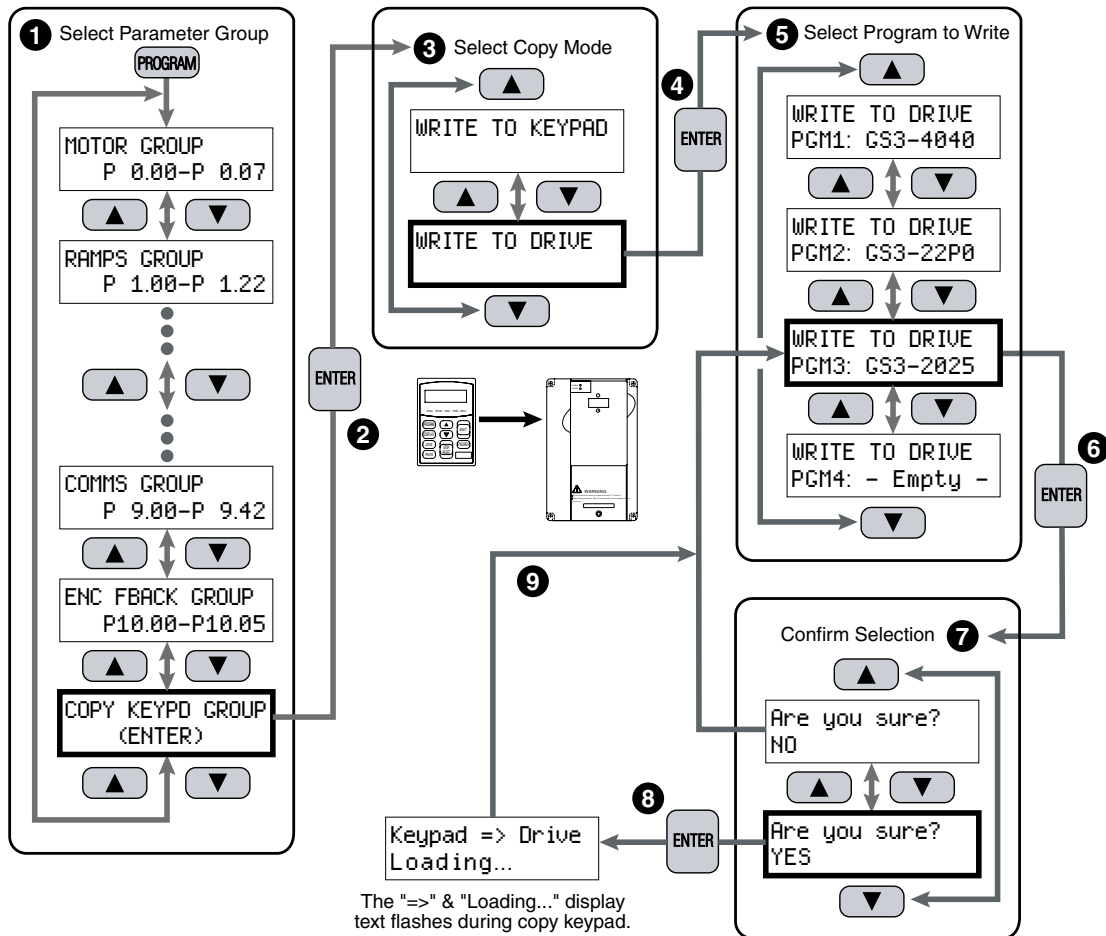

Use the PROGRAM key to back out of the various menu selections without saving changes.



The warning message RATING MISMATCH will be displayed on the LCD display if trying to do a WRITE TO DRIVE copy mode and selecting an existing program that does not match the drive being used.