

**P/N: GSOPK20**

## GENESIS SWING OUT PANEL KIT

### Installation Instructions:

The kit consists of the following components:

- Item A) Custom Piano Hinge – QTY (1)
- Item B) Pan Head Thread Cutting Screws, #10-16 X 1/2" – QTY (4)
- Item C) Spacer, 3/8" O.D. X 0.219 I.D. X 10.219 long – QTY (4)
- Item D) Panel Pad Kit – QTY (1)
- Item E) Thumb Screw, 1/4-20 X 1/2" Long – QTY (2)
- Item F) Nylon Retain Washer – QTY (2)

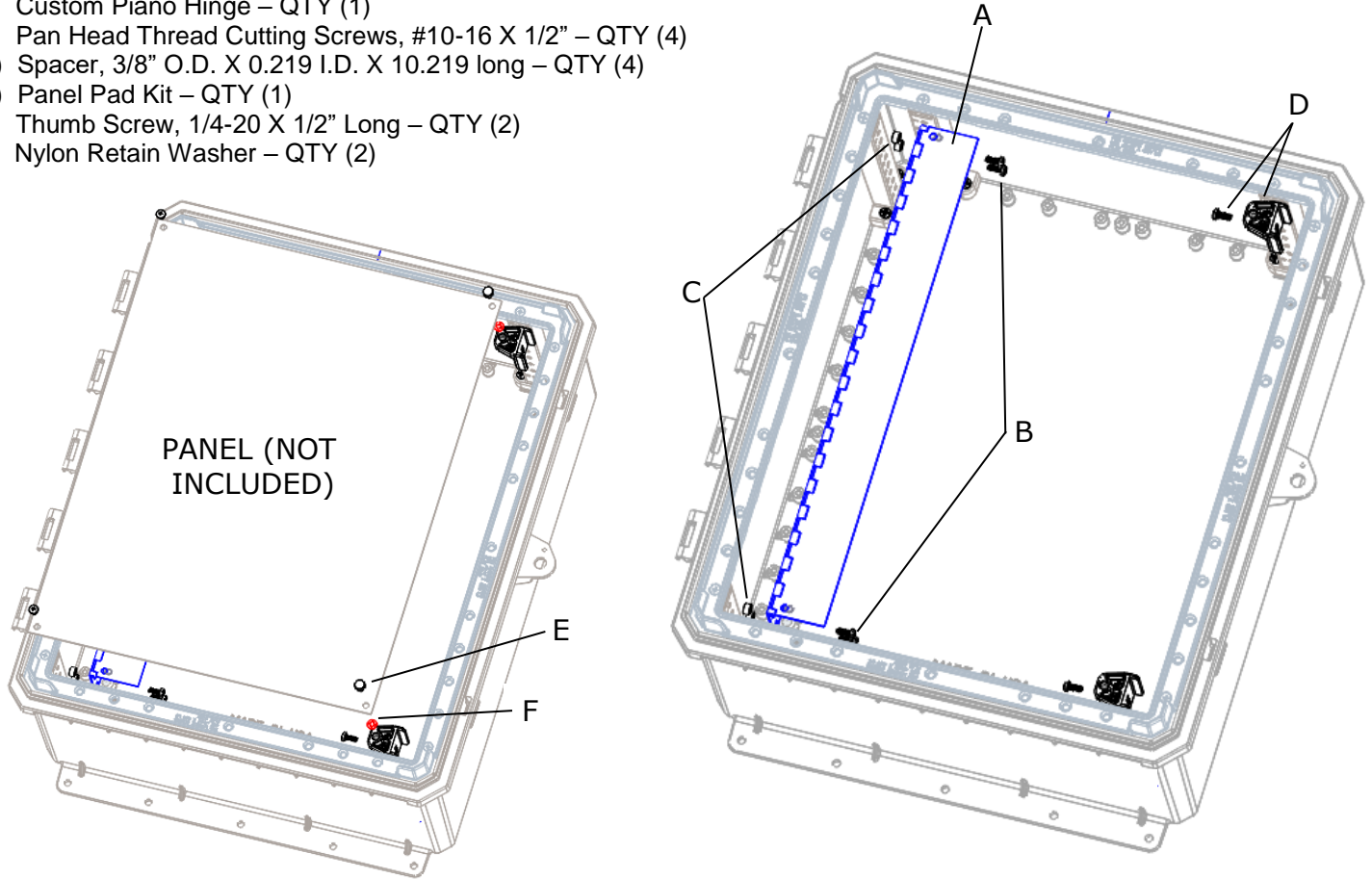

- 1) Install Piano Hinge (A) to Multi-Max rail on hinge side of enclosure. Secure with #10 Pan Head Thread Cutting Screws (B) and 3/8" Spacer (C) as shown (x4), with Philips head #2 screwdriver, hand tight. Location of Piano Hinge dependent on finished Panel height per the customer. The tallest Piano Hinge position is using the first upper hole position on the rail with the bottom set of holes on Hinge.
- 2) Position and Install Panel Pad Kit (D) to Multi-Max rail (x2) on latch side, parallel to enclosure hinge, location in outer corners. Secure with #10 Pan Head Thread Cutting Screws (x2), using Philips head #2 screwdriver, hand tight. Location of Panel Pad dependent on finished Panel height per the customer.
- 3) Place Swing Panel on Piano Hinge and secure with #10-32 x 5/16" lg Pan Head Screw (x2). Start screw thread into Piano Hinge insert and thread in 75% of screw, keep loose.
- 4) Insert Thumb Screw (E) (x2) into hole in Swing Panel and secure from opposite side with Retain Washer (F) (x2). Thread Thumb Screw (E) (x2) into insert in Panel Pad and tighten, hand tight.
- 5) Torque #10-32 Pan Head Screw (x2) at the Piano Hinge end to 20 in-lbs.
- 6) Swing out panel to test.