



# Non-Contact RFID Coded Safety Switches

## SPF and LPF Operating Instructions



**SPF**



**LPF**

**READ AND UNDERSTAND THESE INSTRUCTIONS BEFORE INSTALLING, OPERATING, OR MAINTAINING THIS EQUIPMENT.**

The product is designed to be a component of a customized safety oriented control system. It is the responsibility of each manufacturer to ensure the correct overall functionality of its systems and machines. IDEM, its subsidiaries and affiliates, are not in a position to guarantee all of the characteristics of a given system or product not designed by IDEM.

**APPLICATION:**

RFID Coded Non-Contact Safety Switches are designed to interlock hinged, sliding or removable guard doors. They are specifically advantageous when:

- a) poor guard alignment exists
- b) high level anti-tamper is required
- c) high hygiene requirements exist e.g. food industry hose down
- d) long mechanical life is required (no moving or touching parts)

When used in combination with a Dual Channel Safety Relay or Control Device, Non-Contact Safety Switches can be used to provide protection up to Category 4 and PLe to ISO13849-1.

**OPERATION:**

All RFID Coded Non-Contact Safety Switches are designed to conform to EN60947-5-3 and be used as directed by ISO14119 and EN ISO12100.

They have coded RFID and magnetic sensing which provides a wide (>10mm) sensing distance and provides a high tolerance to misalignment after sensing. They can operate in extreme environments of temperature and moisture. The switches are provided factory coded either uniquely (U types) or by a Master code (M types).

For U types the individual code numbers are shown on the reverse of the switch / actuator. For Master coded types any actuator will operate any switch.

If a Master type (M) actuator is to be changed then a re-teach process is needed. Power down – place new actuator to switch – Power up.

**IMPORTANT:**

Record any RFID codes as required by factory rules or with reference to any risk assessment for the particular application.

The Risk Assessment for the particular application should include the risk of spare actuators. Spare actuators should not be readily available and must be securely controlled.

The safety functions and mechanics must be tested regularly. For applications where infrequent guard access is foreseeable, the system must have a manual function test to detect a possible accumulation of faults. At least once per month for PLe Cat3/4 or once per year for PLd Cat3 (ISO13849-1). Where possible it is recommended that the control system of the machine demands and monitors these tests, and stops or prevents the machine from starting if the test is not done. (See ISO14119).

**INSTALLATION:**

Installation of all RFID Coded Non-Contact Safety Switches must be in accordance with a risk assessment for the individual application.

The use of a Safety Relay or Control Device is required for monitoring RFID Coded switches. These devices monitor 2 redundant circuits as per ISO13849-1 for up to PLe / Category 4 protection.

M4 mounting bolts must be used to fix the switches. Tightening torque for mounting bolts to ensure reliable fixing is 1.0 Nm. Always mount on Non Ferrous materials.

The recommended setting gap is 5mm. The Safety Switch must not be used as a mechanical stop or be adjusted by striking with a hammer.

The actuator must not be allowed to strike the switch. Do not mount adjacent switches or actuators closer than 30mm.

Typical misalignment tolerance after setting is 5mm.

After installation always check each switch function by opening and closing each guard individually in turn and ensuring that the Green LED on the switch and the LEDs on the Safety Relay or Control Device are illuminated when the switch is closed and are extinguished when the switch is open. Check that the machine stops and cannot be re-started when each switch is open.

**Actuator Operating Directions:**

Align actuator and switch using the target lines

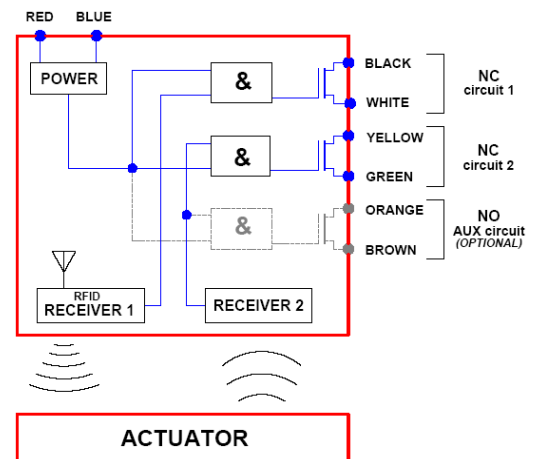
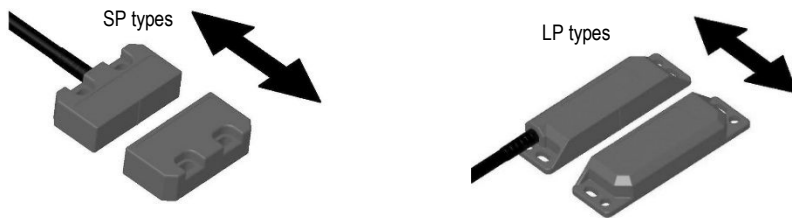

**Diagnostics:** LED Green 'on' = NC1 and NC2 closed.

**MAINTENANCE:**

Monthly: Check alignment of actuator and look for signs of mechanical damage to the switch casing. Check wiring for signs of damage.

Check each switch function by opening and closing each guard individually in turn and ensuring that the Green LED on the switch and the appropriate LED's on the Control Device are illuminated when the switch is closed and are extinguished when the switch is open. Check that the machine stops and cannot be re-started when each switch is open.



**WARNING: DO NOT DEFEAT, TAMPER, OR BYPASS THE SAFETY FUNCTION. FAILURE TO DO SO CAN RESULT IN DEATH OR SERIOUS INJURY.**

**AVERTISSEMENT: NE PAS DESACTIVER, MODIFIER, RETIRER, OU CONTOURNER CETI INTERVERROUILLAGE IL PEUT EN RESULTER DES BLESSURES GRAVES DU PERSONNEL UTILISATEUR.**

**Original Instructions.**

To request this data sheet in other languages please contact [info@idemsafety.com](mailto:info@idemsafety.com)  
 Um dieses Datenblatt in Deutscher Sprache wenden Sie sich bitte anfordern [info@idemsafety.com](mailto:info@idemsafety.com)  
 Pour obtenir cette fiche en Français, veuillez contacter [info@idemsafety.com](mailto:info@idemsafety.com)  
 Para solicitar esta hoja de datos en Español, por favor contacto con [info@idemsafety.com](mailto:info@idemsafety.com)

## Switch Dimensions (mm)

# Non-Contact RFID Coded Safety Switches

### SP Housing and Actuator

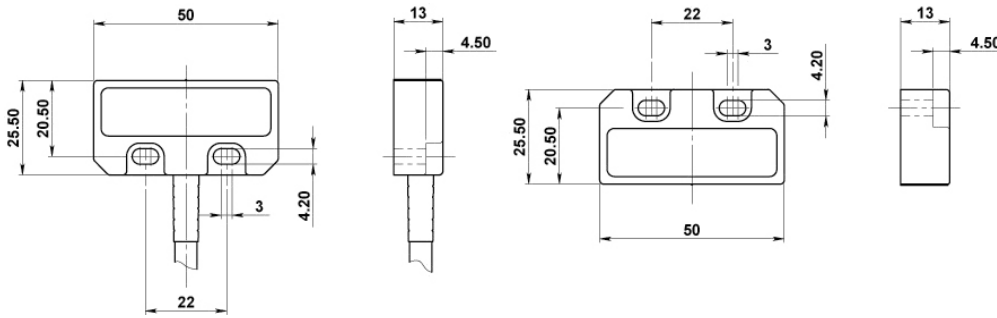

### LP Housing and Actuator

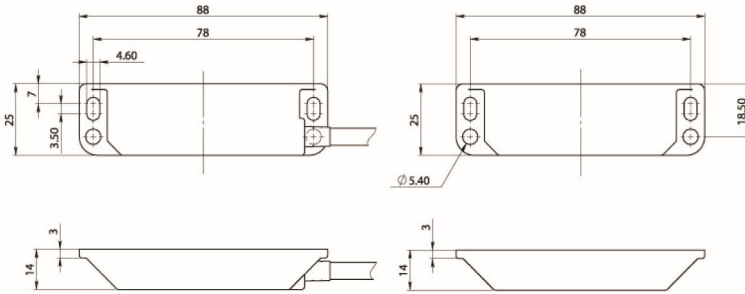

### Alternative Quick Connect Flying Lead (QC) – M12 4-Way Male

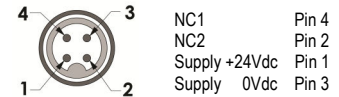

Pin view from Switch

### Single switch to SCR-2 or SCR-3 Safety Relay

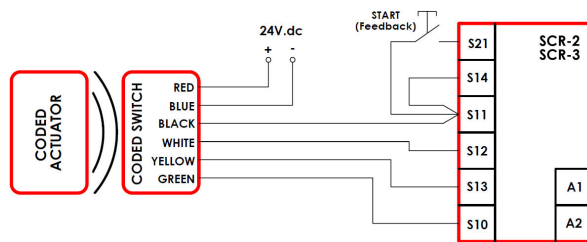

### Single switch to SCR-21-i or SCR-31-i Safety Relay (Viper series)

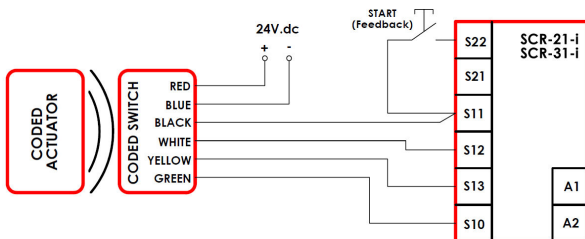

### Series connection to SCR relays

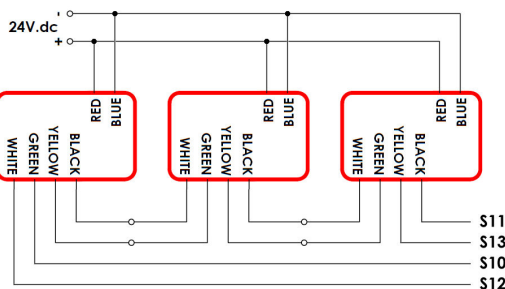

Standard Quick Connect (QC)	Flying Lead Colours	Circuit (Actuator present)	Output Types Solid State	
M12 8 way Male Plug (on Flying Lead 250mm) (Pin view from switch)				
	8	Orange	Auxiliary (NO)	
	5	Brown	Auxiliary (NO)	
	4	Yellow	NC 2	
	6	Green	NC 2	
	7	Black	NC 1	
	1	White	NC 1	
	2	Red	Supply +24Vdc	+/- 10%
	3	Blue	Supply 0Vdc	USE SELV / PELV

For all switches the NC circuits are closed when the guard is closed and the actuator is present.

### Standards:

ISO14119 EN 60947-5-3 EN 60204-1 ISO 13849-1 EN 62061 UL508

### Technical Data:

Dielectric Withstand:	250V.ac
Insulation Resistance:	100 Mohms
Recommended setting gap:	5mm
Switching Distance:	Sao 10mm Close Sar 20mm Open
Tolerance to Misalignment:	5mm in any direction from 5mm setting gap
Switching frequency:	1.0 Hz maximum
Approach speed:	200mm/m to 1000mm/s
Body material:	Polyester
Temperature Range:	-25/80C 105C for CIP/SIP cleaning (temporary)
Enclosure Protection:	IP67 and IP69K (QC versions IP67 for connector)
Cable Type:	PVC 8 core 6mm O.D.
Mounting Bolts:	2 x M4 Tightening torque 1.0 Nm
Mounting Position:	Any

### Characteristic Data according to IEC62061 (used as a sub system)

Safety Integrity Level	SIL3	
PFH (1/h)	4.77E-10	Corresponds to 4.8% of SIL3
PFD	4.18E-05	Corresponds to 4.2% of SIL3
Proof Test Interval T <sub>1</sub>	20a	

### Characteristic Data according to EN ISO13849-1

Performance Level	e	If both channels are used in combination with a SIL3/PLe control device
Category	Cat4	
MTTF <sub>d</sub>	1100a	
Diagnostic Coverage DC	99% (high)	

Number of operating days per year: d<sub>op</sub> = 365d

Number of operating hours per day: h<sub>op</sub> = 24h

B10<sub>a</sub>

no mechanical parts implemented

When the product is used deviant from these assumptions (different load, operating frequency, etc.) the values have to be adjusted accordingly.

### Information with regard to UL 508:

Type 1 Enclosures.

Maximum temperature 50°C. Maximum output 24V.dc 100mA.

Powered by Class 2 or equivalent.