

SOLO Basic

Temperature Controller

User Manual

Manual Number: SLB-USER-M



SOLO BASIC TEMPERATURE CONTROLLER USER MANUAL



Please include the Manual Number and the Manual Issue, both shown below, when communicating with Technical Support regarding this publication.

Manual Number: SLB-USER-M

Issue: 1st Edition

Issue Date: 02/19

| Publication History | | |
|---------------------|-------|------------------------|
| Issue | Date | Description of Changes |
| 1st Edition | 02/19 | Original Issue |

⚡ WARNING ⚡

Thank you for purchasing automation equipment from AutomationDirect.com™, doing business as AutomationDirect. We want your new automation equipment to operate safely. Anyone who installs or uses this equipment should read this publication (and any other relevant publications) before installing or operating the equipment.

To minimize the risk of potential safety problems, you should follow all applicable local and national codes that regulate the installation and operation of your equipment. These codes vary from area to area and usually change with time. It is your responsibility to determine which codes should be followed, and to verify that the equipment, installation, and operation is in compliance with the latest revision of these codes.

At a minimum, you should follow all applicable sections of the National Fire Code, National Electrical Code, and the codes of the National Electrical Manufacturer's Association (NEMA). There may be local regulatory or government offices that can also help determine which codes and standards are necessary for safe installation and operation.

Equipment damage or serious injury to personnel can result from the failure to follow all applicable codes and standards. We do not guarantee the products described in this publication are suitable for your particular application, nor do we assume any responsibility for your product design, installation, or operation.

Our products are not fault-tolerant and are not designed, manufactured or intended for use or resale as on-line control equipment in hazardous environments requiring fail-safe performance, such as in the operation of nuclear facilities, aircraft navigation or communication systems, air traffic control, direct life support machines, or weapons systems, in which the failure of the product could lead directly to death, personal injury, or severe physical or environmental damage ("High Risk Activities"). AutomationDirect specifically disclaims any expressed or implied warranty of fitness for High Risk Activities.

For additional warranty and safety information, see the Terms and Conditions section of our catalog. If you have any questions concerning the installation or operation of this equipment, or if you need additional information, please call us at 770-844-4200.

This publication is based on information that was available at the time it was printed. At AutomationDirect we constantly strive to improve our products and services, so we reserve the right to make changes to the products and/or publications at any time without notice and without any obligation. This publication may also discuss features that may not be available in certain revisions of the product.

Trademarks

This publication may contain references to products produced and/or offered by other companies. The product and company names may be trademarked and are the sole property of their respective owners. AutomationDirect disclaims any proprietary interest in the marks and names of others.

**Copyright 2018-2019, AutomationDirect.com™ Incorporated
All Rights Reserved**

No part of this manual shall be copied, reproduced, or transmitted in any way without the prior, written consent of AutomationDirect.com™ Incorporated. AutomationDirect retains the exclusive rights to all information included in this document.

⚡ AVERTISSEMENT ⚡

Nous vous remercions d'avoir acheté l'équipement d'automatisation de AutomationDirect.com™, en faisant des affaires comme AutomationDirect. Nous tenons à ce que votre nouvel équipement d'automatisation fonctionne en toute sécurité. Toute personne qui installe ou utilise cet équipement doit lire la présente publication (et toutes les autres publications pertinentes) avant de l'installer ou de l'utiliser.

Afin de réduire au minimum le risque d'éventuels problèmes de sécurité, vous devez respecter tous les codes locaux et nationaux applicables régissant l'installation et le fonctionnement de votre équipement. Ces codes diffèrent d'une région à l'autre et, habituellement, évoluent au fil du temps. Il vous incombe de déterminer les codes à respecter et de vous assurer que l'équipement, l'installation et le fonctionnement sont conformes aux exigences de la version la plus récente de ces codes.

Vous devez, à tout le moins, respecter toutes les sections applicables du Code national de prévention des incendies, du Code national de l'électricité et des codes de la National Electrical Manufacturer's Association (NEMA). Des organismes de réglementation ou des services gouvernementaux locaux peuvent également vous aider à déterminer les codes ainsi que les normes à respecter pour assurer une installation et un fonctionnement sûrs.

L'omission de respecter la totalité des codes et des normes applicables peut entraîner des dommages à l'équipement ou causer de graves blessures au personnel. Nous ne garantissons pas que les produits décrits dans cette publication conviennent à votre application particulière et nous n'assumons aucune responsabilité à l'égard de la conception, de l'installation ou du fonctionnement de votre produit.

Nos produits ne sont pas insensibles aux défaillances et ne sont ni conçus ni fabriqués pour l'utilisation ou la revente en tant qu'équipement de commande en ligne dans des environnements dangereux nécessitant une sécurité absolue, par exemple, l'exploitation d'installations nucléaires, les systèmes de navigation aérienne ou de communication, le contrôle de la circulation aérienne, les équipements de survie ou les systèmes d'armes, pour lesquels la défaillance du produit peut provoquer la mort, des blessures corporelles ou de graves dommages matériels ou environnementaux («activités à risque élevé»). La société AutomationDirect nie toute garantie expresse ou implicite d'aptitude à l'emploi en ce qui a trait aux activités à risque élevé.

Pour des renseignements additionnels touchant la garantie et la sécurité, veuillez consulter la section Modalités et conditions de notre documentation. Si vous avez des questions au sujet de l'installation ou du fonctionnement de cet équipement, ou encore si vous avez besoin de renseignements supplémentaires, n'hésitez pas à nous téléphoner au 770-844-4200.

Cette publication s'appuie sur l'information qui était disponible au moment de l'impression. À la société AutomationDirect, nous nous efforçons constamment d'améliorer nos produits et services. C'est pourquoi nous nous réservons le droit d'apporter des modifications aux produits ou aux publications en tout temps, sans préavis ni quelque obligation que ce soit. La présente publication peut aussi porter sur des caractéristiques susceptibles de ne pas être offertes dans certaines versions révisées du produit.

Marques de commerce

La présente publication peut contenir des références à des produits fabriqués ou offerts par d'autres entreprises. Les désignations des produits et des entreprises peuvent être des marques de commerce et appartiennent exclusivement à leurs propriétaires respectifs. AutomationDirect nie tout intérêt dans les autres marques et désignations.

**Copyright 2018-2019, AutomationDirect.com™ Incorporated
Tous droits réservés**

Nulle partie de ce manuel ne doit être copiée, reproduite ou transmise de quelque façon que ce soit sans le consentement préalable écrit de la société AutomationDirect.com™ Incorporated. AutomationDirect conserve les droits exclusifs à l'égard de tous les renseignements contenus dans le présent document.

TABLE OF CONTENTS



Chapter 1: Getting Started

| | |
|---|-----|
| Manual Overview | 1-2 |
| Overview of this Publication | 1-2 |
| Who Should Read This Manual..... | 1-2 |
| Technical Support | 1-2 |
| Supplemental Manuals | 1-2 |
| Special Symbols..... | 1-2 |
| SOLO Basic Temperature Controller Introduction | 1-3 |
| General Description..... | 1-3 |
| Unpacking..... | 1-3 |
| Model Number Explanation | 1-4 |
| SOLO Basic Temperature Controller Specifications | 1-5 |

Chapter 2: Installation and Wiring

| | |
|---|-----|
| Ambient Conditions | 2-2 |
| Installation Considerations | 2-2 |
| Mounting Instructions | 2-2 |
| Controller and Panel Cutout Dimensions | 2-4 |
| Terminal Identification | 2-6 |

Chapter 3: Keypad Operation and Setup Parameters

| | |
|---------------------------------|------|
| Display, LCD and Keypad | 3-2 |
| Keypad Operation | 3-3 |
| Setup Parameter Listing | 3-4 |
| Regulation Mode Parameters..... | 3-7 |
| Operation Mode Parameters..... | 3-10 |
| Initial Setting Parameters..... | 3-12 |
| Reset to Factory Default..... | 3-14 |
| Key Lock Function..... | 3-14 |

Chapter 4: Controller Inputs and Outputs

| | |
|---------------------------|-----|
| Control Input Types..... | 4-2 |
| Control Output Types..... | 4-2 |
| Alarm Outputs | 4-5 |

Chapter 5: Control Modes

| | |
|--------------------------------|-----|
| PID Control | 5-2 |
| On / Off Control | 5-3 |
| Manual Control..... | 5-3 |
| Error Display Information..... | 5-3 |

GETTING STARTED



CHAPTER 1

In this Chapter...

| | |
|---|-----|
| Manual Overview | 1-2 |
| Overview of this Publication | 1-2 |
| Who Should Read This Manual..... | 1-2 |
| Technical Support | 1-2 |
| Supplemental Manuals | 1-2 |
| Special Symbols..... | 1-2 |
| SOLO Basic Temperature Controller Introduction | 1-3 |
| General Description..... | 1-3 |
| Unpacking..... | 1-3 |
| Model Number Explanation | 1-4 |
| SOLO Basic Temperature Controller Specifications | 1-5 |

Manual Overview

Overview of this Publication

The SOLO Basic Temperature Controller User Manual describes the installation, configuration, and methods of operation of the SOLO Basic Temperature Controller.

Who Should Read This Manual

This manual contains important information for those who will install, maintain, and/or operate any of the SOLO Basic Temperature Controllers.

Technical Support

By Telephone: 770-844-4200

(Mon.-Fri., 9:00 a.m.-6:00 p.m. E.T.)

On the Web: support.automationdirect.com

Our technical support group is glad to work with you in answering your questions. If you cannot find the solution to your particular application, or, if for any reason you need additional technical assistance, please call technical support at **770-844-4200**. We are available weekdays from 9:00 a.m. to 6:00 p.m. Eastern Time.

We also encourage you to visit our web site where you can find technical and non-technical information about our products and our company. Visit us at **www.automationdirect.com**.

Supplemental Manuals

If you are familiar with industrial control type devices, you may be able to get up and running with just the aid of the Quick Start Guide that is included with each SOLO Basic Temperature Controller.

Special Symbols



When you see the “notepad” icon in the left-hand margin, the paragraph to its immediate right will be a special note.



When you see the “exclamation mark” icon in the left-hand margin, the paragraph to its immediate right will be a warning. This information could prevent injury, loss of property, or even death (in extreme cases).

SOLO Basic Temperature Controller Introduction

General Description

AutomationDirect's SOLO Basic is a single loop temperature controller that can control heating or cooling processes. Depending upon the particular model of controller, the available outputs include relay, voltage pulse or current. On select models there are two alarm outputs available with nine selectable alarm types. SOLO Basic controllers have a single control output that can be used for control of a heating or cooling application. Models with alarm outputs can also be configured to use one of the alarm outputs as a second control output allowing both heating and cooling control or two stage heating or two stage cooling control. There are three types of control modes: PID, ON/OFF and Manual. SOLO Basic can accept various types of thermocouple and RTDs.

Other features include:

- Auto Tuning (AT) function with PID control
- 1/16 DIN panel size
- 2 line x 4 character 7-segment LCD display for Process Value (PV): Red color, and Set Point (SV): Green color
- Selectable display decimal point XXX.X or XXXX
- Selectable between °C and °F
- UL, CUL and CE agency approvals

Unpacking

After receiving the SOLO Basic Temperature Controller, please check for the following:

- Make sure that the package includes the Controller, the mounting bracket and hardware and the Quick Start Guide.
- Inspect the unit to insure it was not damaged during shipment.
- Make sure that the part number indicated on the serial number label corresponds with the part number of your order.

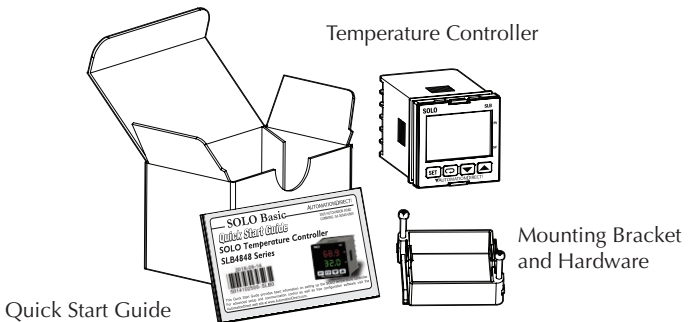

Model Number Explanation

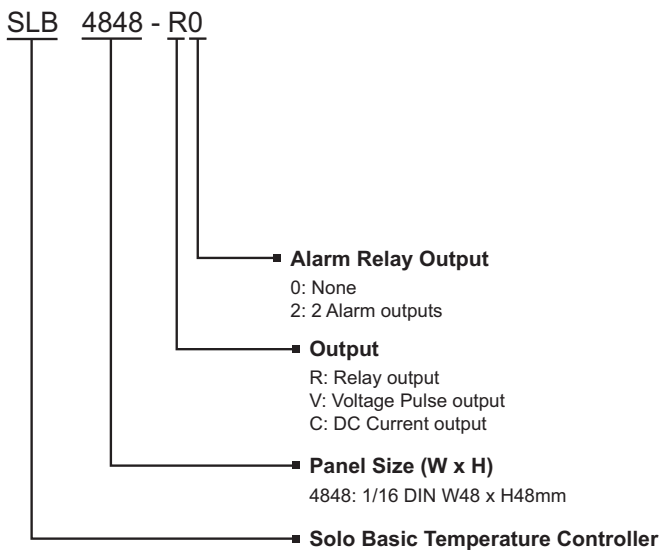

SOLO Basic Temperature Controller Specifications

| Specifications | |
|--|--|
| Input Power Requirements | 100 to 240 VAC 50 / 60 Hz |
| Operation Voltage Range | 85 to 264 VAC |
| Power Consumption | 5 VA Max |
| Control Mode | PID, ON/OFF or Manual |
| Input Accuracy | TC temperature indication accuracy: $\pm(0.3\%$ of span + 1 digit) at 25°C ambient after 20 minutes warm up. Including NIST conformity, cold junction effect, A/D conversion errors and linearization conformity RTD temperature indication accuracy: $\pm(0.2\%$ of span + 1 digit) |
| Vibration Resistance | 10 to 55 Hz, 10 m/s ² for 10 min, each in X, Y and Z directions |
| Display | 2 line x 4 character, 7-segment LED display PV: 11mm red SV: 9.2 mm green |
| Shock Resistance | Max. 300 m/s ² , 3 times in each 3 axes, 6 directions |
| Ambient Temperature Range | 32°F to 122°F (0°C to 50°C) |
| Storage Temperature Range | -4°F to 149°F (-20°C to 65°C) |
| Altitude | 2000m or less |
| Relative Humidity | 35% to 80% (non-condensing) |
| IP Rating | IP66: Complete protection against dust and powerful water jets from all directions. (**inside suitable enclosure) |
| Agency Approvals | UL, CUL, CE (UL file number E311366) |
| Pollution Degree | Degree 2 - Normally, only non-conductive pollution occurs. Temporary conductivity caused by condensation is to be expected. |
| Input Types | |
| • Thermocouple* | K, J, T, E, N, R, S, B, L, U, TXK (Sampling Rate: 100 ms / per scan) |
| • Platinum RTD | 3-wire Pt100, JPt100 (Sampling Rate: 100 ms / per scan) |
| • Copper, Nickel | |
| RTDs | Cu50, Ni120 (Sampling Rate: 100 ms / per scan) |
| Control Output Options | |
| • Relay (R) | SPST max. 5A @ 250 VAC resistive load |
| • Voltage Pulse (V) | DC 12V \pm 15%, output current 40mA Max |
| • Current (C) | DC 4-20 mA output (sourcing) (Load resistance: Max 600 Ω) |
| Alarm Output Option | (2) SPST relays with shared common, 3A @ 250VAC resistive load |
| *Note: Use only ungrounded thermocouples. ** No corrosive gases | |

INSTALLATION AND WIRING



In this Chapter...

| | |
|---|-----|
| Ambient Conditions | 2-2 |
| Installation Considerations..... | 2-2 |
| Mounting Instructions..... | 2-2 |
| Controller and Panel Cutout Dimensions..... | 2-4 |
| Terminal Identification..... | 2-6 |

Ambient Conditions

| Ambient Conditions | |
|---------------------------|---|
| Ambient Temperature Range | 32°F to 122°F (0°C to 50°C) |
| Storage Temperature Range | -4°F to 149°F (-20°C to 65°C) |
| Relative Humidity | 35% to 80% (non-condensing) |
| Altitude | 2000m or lower above sea level, keep from corrosive gas, liquid and dust |
| Pollution Degree | Degree 2 - Normally, only non-conductive pollution occurs. Temporary conductivity caused by condensation is to be expected. |
| Vibration Resistance | 10 to 55 Hz, 10 m/s ² for 10 min, each in X, Y and Z directions |
| Shock Resistance | Max. 300 m/s ² , 3 times in each 3 axes, 6 directions |
| IP Rating | IP66: Complete protection against dust and powerful water jets from all directions. (*inside suitable enclosure) |
| * No corrosive gases | |

Installation Considerations

Improper installation of the controller will greatly reduce its life. Be sure to observe the following precautions when selecting a mounting location:



Warning: Failure to observe these precautions may damage the controller and void the warranty!

- Do not mount the controller near heat-radiating elements or in direct sunlight.
- Do not install the controller in a place subjected to high temperature, high humidity, excessive vibration, corrosive gases or liquids, or airborne dust or metallic particles.
- Do not restrict the air flow to the vent opening on the controller housing
- This controller is an open-type unit and must be placed in an enclosure to ensure proper operation and maintain the IP66 rating.

Mounting Instructions

SLB4848 Series

SOLO Basic temperature controllers should be mounted through a cutout in an enclosure or panel by using the dimensions shown on page 2–4. The directions for mounting the controller through a cutout are:

1. Insert the temperature controller through the panel cutout.
2. Slide the M3X0.5 nut into the opening in the top of the mounting bracket and insert the M3X0.5 X 30mm mounting screw in the mounting bracket.

3. Insert the mounting bracket into the mounting groove at the right and left of the controller, and push the mounting bracket forward until the bracket stops.
4. Tighten top and bottom screws evenly to secure temperature controller in place (The screw torque should be 0.4 to 0.5 N.m).

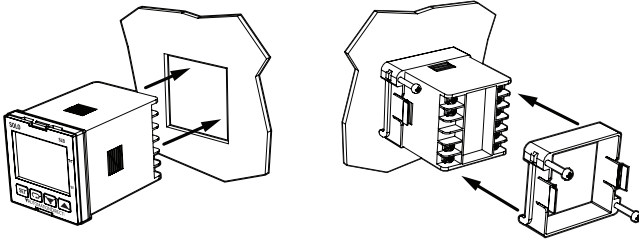

Controller and Panel Cutout Dimensions

SLB4848 Series

Minimum Cutout and Spacing

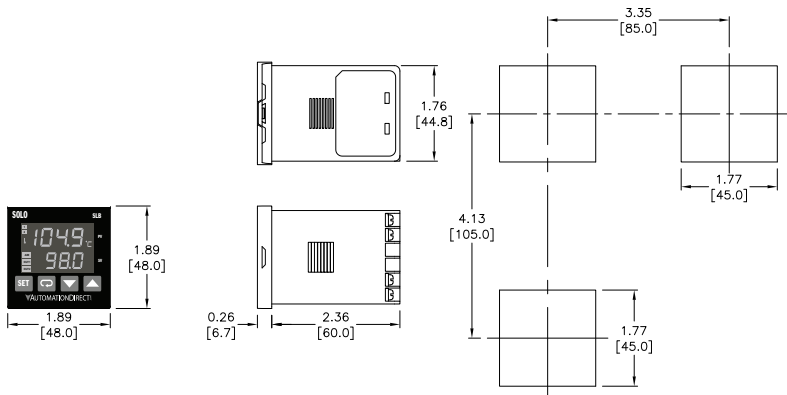

Safety Information

DANGER!



Warning: To minimize the risk of potential safety problems, you should follow all applicable local and national codes that regulate the installation and operation of your equipment. These codes vary from area to area and it is your responsibility to determine which codes should be followed, and to verify that the equipment, installation, and operation are in compliance with the latest revision of these codes



Warning: To prevent electric shock, do not touch the AC terminals while power is supplied to the controller.



Warning: This controller is an open-type temperature controller. Make sure to evaluate any dangerous application in which a serious human injury or serious property damage may occur.

Wiring Notes: PLEASE READ PRIOR TO INSTALLATION.

Equipment damage or serious injury to personnel can result from the failure to follow all applicable codes and standards. We do not guarantee the products described in this publication are suitable for your particular application, nor do we assume any responsibility for your product design, installation, or operation.

If you have any questions concerning the installation or operation of this equipment, or if you need additional information, please call us at 1-800-633-0405 or 770-844-4200.

This publication is based on information that was available at the time it was printed. At Automationdirect.com® we constantly strive to improve our products and services, so we reserve the right to make changes to the products and/or publications at any time without notice and without obligation. This publication may also discuss features that may not be available in certain revisions of the product.

1. Always use recommended solder-less terminals: Fork terminal with isolation (M3 screw, width is 5.8mm, hole diameter 3.2mm). Screw size: M3 x 4.5 (With 6 x 6 square washer). Recommended tightening torque: 0.4 Nm (4kgfcm). Applicable wire: Solid/twisted wire 14AWG to 22AWG.
2. Protect the controller from dust or foreign objects as they can cause the controller to malfunction.
3. Never modify or disassemble the controller.
4. Do not connect anything to the “Not used” terminals.
5. Make sure all wires are connected to the correct polarity of terminals.
6. Do not install and/or use the controller in places subject to: (a) Dust or corrosive gases and liquid (b) High humidity (c) Vibration or shock (d) EMI / RFI (e) high temperature.
7. Power must be turned off when wiring or changing a sensor.
8. Be sure to use wires that match the thermocouple types when extending or connecting thermocouple wires.
9. Use wires with correct resistance when extending or connecting a RTD.
10. Keep the wire as short as possible when wiring a RTD to the controller and route power wires as far as possible from sensor wires to prevent interference and induced noise.
11. This controller is an open-type unit and must be placed in an enclosure to ensure proper operation and maintain the **IP66 rating**.
12. Make sure power cables and signals from instruments are all installed properly before energizing the controller, otherwise serious damage may occur.
13. To prevent electric shock, do not touch the terminals on the controller or try to repair the controller when power is applied.
14. Do not use acid or alkaline liquids for cleaning. Use a soft, dry cloth to clean the controller.
15. This instrument is not furnished with a power switch or fuse. Therefore, if a fuse or power switch is required, install the protection close to the instrument. Recommended fuse rating: Rated voltage 250 V, Rated current 1 A. Fuse type: Time-delay fuse. See the AutomationDirect catalog for the appropriate fuse for the specific application.
16. Note: This controller does not provide overcurrent protection. Use of this product requires that suitable overcurrent protection device(s) must be added to ensure compliance with all relevant electrical standards and codes. (Rated 250 V, 15 Amps max). A suitable disconnecting device should be provided near the controller in the end-use installation.

Terminal Identification

SLB4848 Series Wiring

SLB4848-R0

(No alarm output)

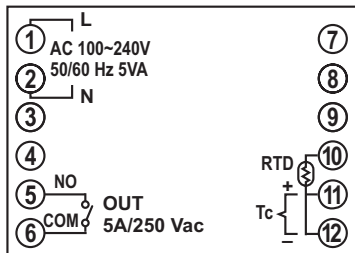

SLB4848-R2

(2 sets of alarm outputs)

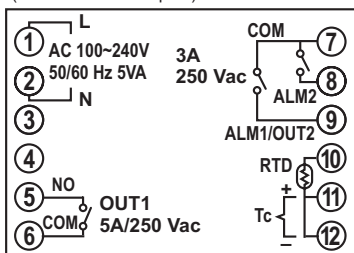

SLB4848-C0

SLB4848-V0

(No alarm output)

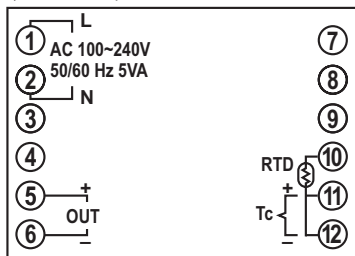

SLB4848-C2

SLB4848-V2

(2 sets of alarm outputs)

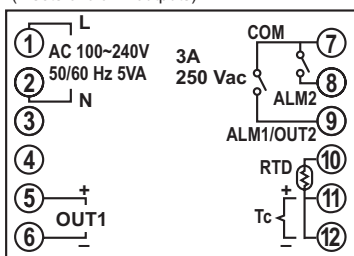

KEYPAD OPERATION AND SETUP PARAMETERS



CHAPTER 3

In this Chapter...

| | |
|---------------------------------|------|
| Display, LCD and Keypad | 3-2 |
| Keypad Operation | 3-3 |
| Setup Parameter Listing | 3-4 |
| Regulation Mode Parameters..... | 3-7 |
| Operation Mode Parameters..... | 3-10 |
| Initial Setting Parameters..... | 3-12 |
| Reset to Factory Default..... | 3-14 |
| Key Lock Function..... | 3-14 |

Display, LCD and Keypad

The SOLO temperature controller has a two color seven segment LCD display and four function buttons.

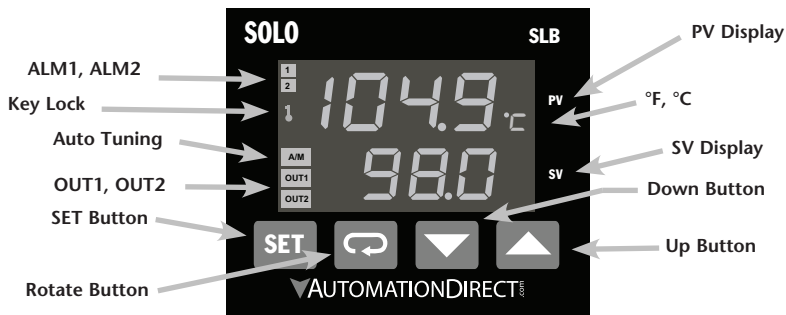

PV Display

The Process Value Display. Displays the value from the input source or the parameter source.

SV Display

The Set Value Display. Displays the set point of the process, the parameter operation read value, manipulated variable, or the set value of the parameter.

A/M Indicator

A/M indicator flashes when the Auto Tuning operation is ON and is solid when the controller is in Manual Mode.

OUT1, OUT2 Indicators

Output indicators light when the output is ON.

°F, °C Indicator

Temperature unit indicator. °C: Celsius, °F: Fahrenheit

1, 2 Indicators

Alarm output indicators light when appropriate alarm is activated.

Key Indicator

Key indicator lights when key lock is enabled.

Keypad Operation

Function Buttons

SET

SET Button

Press the SET button to select the desired function mode and confirm the setting value.



Rotate Button

Press the Rotate button to select parameters within the function mode.



Down Button

Press the Down button to decrease values displayed on the SV display. Hold down this button to speed up the decrement.



Up Button

Press the Up button to increase values displayed on the SV display. Hold down this button to speed up the increment.

Initial Power up

When power is first applied to the temperature controller, the module information splash screen appears. This screen shows the firmware version on the PV displays and the output type for that particular model and the current input setting on the SV display. After three seconds, the controller will automatically proceed to the Operation mode main screen.

Keypad Operation

The temperature controller has three function modes: Initial Setting mode, Operation mode and Regulation mode. Press and hold the SET button for three seconds to go into the Initial Setting mode. Press the SET button for less than three seconds to access the Regulation mode. Press the Rotate button while inside any of the three function modes to scroll through the individual parameters for each function mode. Use the Up and Down buttons to change the individual parameter values. Pressing the SET button saves the parameter values. Press the SET button again to return the controller to the Operation mode main screen.

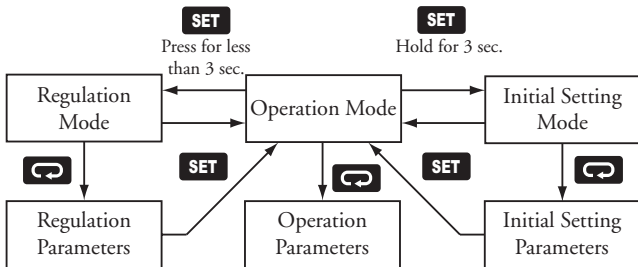

Setup Parameter Listing













Regulation Mode Parameters

Press the **SET** button to access these parameters.

| Regulation Mode Parameter Availability | | | | | | | | | | | | | | | | |
|--|-------------------------------|-----------------|----|----|----|----|----|--------------|----------|--------|-------------------|---------|-----------------|-----------------|-----------------|-----------------|
| Display | Parameter Name | Controller Type | | | | | | Control Mode | | | Heating / Cooling | | | | | |
| | | R0 | V0 | C0 | R2 | V2 | C2 | PID | ON / OFF | Manual | Heating | Cooling | Heating/Cooling | Cooling/Heating | Heating/Heating | Cooling/Cooling |
| AL | Auto Tuning | ✓ | ✓ | ✓ | ✓ | ✓ | ✓ | ✓ | - | - | ✓ | ✓ | ✓ | ✓ | ✓ | ✓ |
| P | Proportion Band | ✓ | ✓ | ✓ | ✓ | ✓ | ✓ | ✓ | - | - | ✓ | ✓ | ✓ | ✓ | ✓ | ✓ |
| I | Integral Time | ✓ | ✓ | ✓ | ✓ | ✓ | ✓ | ✓ | - | - | ✓ | ✓ | ✓ | ✓ | ✓ | ✓ |
| D | Derivative Time | ✓ | ✓ | ✓ | ✓ | ✓ | ✓ | ✓ | - | - | ✓ | ✓ | ✓ | ✓ | ✓ | ✓ |
| PdOF | PD Control Offset | ✓ | ✓ | ✓ | ✓ | ✓ | ✓ | ✓ | - | - | ✓ | ✓ | ✓ | ✓ | ✓ | ✓ |
| o1-S | Output 1 Hysteresis | ✓ | ✓ | ✓ | ✓ | ✓ | ✓ | - | ✓ | - | ✓ | ✓ | ✓ | ✓ | ✓ | ✓ |
| o1-H | Output 1 Heating Period | ✓ | ✓ | ✓ | ✓ | ✓ | ✓ | ✓ | - | ✓ | ✓ | - | ✓ | - | ✓ | - |
| o1-C | Output 1 Cooling Period | ✓ | ✓ | ✓ | ✓ | ✓ | ✓ | ✓ | - | ✓ | - | ✓ | - | ✓ | - | ✓ |
| o2-S | Output 2 Hysteresis | - | - | - | ✓ | ✓ | ✓ | - | ✓ | - | - | - | ✓ | ✓ | ✓ | ✓ |
| o2-H | Output 2 Heating Period | - | - | - | ✓ | ✓ | ✓ | ✓ | - | ✓ | - | - | - | ✓ | ✓ | - |
| o2-C | Output 2 Cooling Period | - | - | - | ✓ | ✓ | ✓ | ✓ | - | ✓ | - | - | ✓ | - | - | ✓ |
| CoEF | Proportional Band Coefficient | - | - | - | ✓ | ✓ | ✓ | ✓ | - | - | - | - | ✓ | ✓ | - | - |
| dERd | Deadband | - | - | - | ✓ | ✓ | ✓ | ✓ | ✓ | - | - | - | ✓ | ✓ | - | - |
| Pv-F | PV Filter | ✓ | ✓ | ✓ | ✓ | ✓ | ✓ | ✓ | ✓ | ✓ | ✓ | ✓ | ✓ | ✓ | ✓ | ✓ |
| Pv-r | PV Filter Range | ✓ | ✓ | ✓ | ✓ | ✓ | ✓ | ✓ | ✓ | ✓ | ✓ | ✓ | ✓ | ✓ | ✓ | ✓ |
| PvOF | PV Offset | ✓ | ✓ | ✓ | ✓ | ✓ | ✓ | ✓ | ✓ | ✓ | ✓ | ✓ | ✓ | ✓ | ✓ | ✓ |
| PvGA | PV Gain | ✓ | ✓ | ✓ | ✓ | ✓ | ✓ | ✓ | ✓ | ✓ | ✓ | ✓ | ✓ | ✓ | ✓ | ✓ |
| ALH | Analog High Adjustment | - | - | ✓ | - | - | ✓ | ✓ | ✓ | ✓ | ✓ | ✓ | ✓ | ✓ | ✓ | ✓ |
| ALL | Analog Low Adjustment | - | - | ✓ | - | - | ✓ | ✓ | ✓ | ✓ | ✓ | ✓ | ✓ | ✓ | ✓ | ✓ |

Operation Mode Parameters

Press the  button to access these parameters.

| Operation Mode Parameter Availability | | | | | | | | | | | | | | | | |
|--|------------------------|-----------------|----|----|----|----|----|--------------|---------|--------|-------------------|---------|-----------------|-----------------|-----------------|-----------------|
| Display | Parameter Name | Controller Type | | | | | | Control Mode | | | Heating / Cooling | | | | | |
| | | R0 | V0 | C0 | R2 | V2 | C2 | PID | ON /OFF | Manual | Heating | Cooling | Heating/Cooling | Cooling/Heating | Heating/Heating | Cooling/Cooling |
|  | Run / Stop | ✓ | ✓ | ✓ | ✓ | ✓ | ✓ | ✓ | ✓ | ✓ | ✓ | ✓ | ✓ | ✓ | ✓ | ✓ |
|  | Decimal Point Position | ✓ | ✓ | ✓ | ✓ | ✓ | ✓ | ✓ | ✓ | ✓ | ✓ | ✓ | ✓ | ✓ | ✓ | ✓ |
|  | Lock Mode | ✓ | ✓ | ✓ | ✓ | ✓ | ✓ | ✓ | ✓ | ✓ | ✓ | ✓ | ✓ | ✓ | ✓ | ✓ |
|  | Alarm 1 High Limit | - | - | - | ✓ | ✓ | ✓ | ✓ | ✓ | ✓ | ✓ | ✓ | - | - | - | - |
|  | Alarm 1 Low Limit | - | - | - | ✓ | ✓ | ✓ | ✓ | ✓ | ✓ | ✓ | ✓ | - | - | - | - |
|  | Alarm 2 High Limit | - | - | - | ✓ | ✓ | ✓ | ✓ | ✓ | ✓ | ✓ | ✓ | ✓ | ✓ | ✓ | ✓ |
|  | Alarm 2 Low Limit | - | - | - | ✓ | ✓ | ✓ | ✓ | ✓ | ✓ | ✓ | ✓ | ✓ | ✓ | ✓ | ✓ |
|  | Output 1 Level | ✓ | ✓ | ✓ | ✓ | ✓ | ✓ | ✓ | ✓ | ✓ | ✓ | ✓ | ✓ | ✓ | ✓ | ✓ |
|  | Output 2 Level | - | - | - | ✓ | ✓ | ✓ | ✓ | ✓ | ✓ | - | - | ✓ | ✓ | ✓ | ✓ |
|  | Output 1 Upper Limit | ✓ | ✓ | ✓ | ✓ | ✓ | ✓ | ✓ | ✓ | ✓ | ✓ | ✓ | ✓ | ✓ | ✓ | ✓ |
|  | Output 1 Lower Limit | ✓ | ✓ | ✓ | ✓ | ✓ | ✓ | ✓ | ✓ | ✓ | ✓ | ✓ | ✓ | ✓ | ✓ | ✓ |
|  | Output 2 Upper Limit | - | - | - | ✓ | ✓ | ✓ | ✓ | ✓ | ✓ | - | - | ✓ | ✓ | ✓ | ✓ |
|  | Output 2 Lower Limit | - | - | - | ✓ | ✓ | ✓ | ✓ | ✓ | ✓ | - | - | ✓ | ✓ | ✓ | ✓ |

Initial Setting Parameters

Press the **SET** button for more than three seconds to access these parameters.

| Initial Setting Mode Parameter Availability | | | | | | | | | | | | | | | | |
|---|-------------------|-----------------|----|----|----|----|----|--------------|---------|--------|-------------------|---------|-----------------|-----------------|-----------------|-----------------|
| Display | Parameter Name | Controller Type | | | | | | Control Mode | | | Heating / Cooling | | | | | |
| | | R0 | V0 | C0 | R2 | V2 | C2 | PID | ON /OFF | Manual | Heating | Cooling | Heating/Cooling | Cooling/Heating | Cooling/Cooling | Heating/Heating |
| ENP_n | Input Type | ✓ | ✓ | ✓ | ✓ | ✓ | ✓ | ✓ | ✓ | ✓ | ✓ | ✓ | ✓ | ✓ | ✓ | ✓ |
| EPUn | Temperature Unit | ✓ | ✓ | ✓ | ✓ | ✓ | ✓ | ✓ | ✓ | ✓ | ✓ | ✓ | ✓ | ✓ | ✓ | ✓ |
| EP-H | Input Range High | ✓ | ✓ | ✓ | ✓ | ✓ | ✓ | ✓ | ✓ | ✓ | ✓ | ✓ | ✓ | ✓ | ✓ | ✓ |
| EP-L | Input Range Low | ✓ | ✓ | ✓ | ✓ | ✓ | ✓ | ✓ | ✓ | ✓ | ✓ | ✓ | ✓ | ✓ | ✓ | ✓ |
| Et-L | Control Mode | ✓ | ✓ | ✓ | ✓ | ✓ | ✓ | ✓ | ✓ | ✓ | ✓ | ✓ | ✓ | ✓ | ✓ | ✓ |
| S-HC | Heating / Cooling | ✓ | ✓ | ✓ | ✓ | ✓ | ✓ | ✓ | ✓ | ✓ | ✓ | ✓ | ✓ | ✓ | ✓ | ✓ |
| ALR1 | Alarm 1 | - | - | - | ✓ | ✓ | ✓ | ✓ | ✓ | ✓ | ✓ | ✓ | - | - | - | - |
| AL1o | Alarm 1 Options | - | - | - | ✓ | ✓ | ✓ | ✓ | ✓ | ✓ | ✓ | ✓ | - | - | - | - |
| AL1d | Alarm 1 Delay | - | - | - | ✓ | ✓ | ✓ | ✓ | ✓ | ✓ | ✓ | ✓ | - | - | - | - |
| ALR2 | Alarm 2 | - | - | - | ✓ | ✓ | ✓ | ✓ | ✓ | ✓ | ✓ | ✓ | ✓ | ✓ | ✓ | ✓ |
| AL2o | Alarm 2 Options | - | - | - | ✓ | ✓ | ✓ | ✓ | ✓ | ✓ | ✓ | ✓ | ✓ | ✓ | ✓ | ✓ |
| AL2d | Alarm 2 Delay | - | - | - | ✓ | ✓ | ✓ | ✓ | ✓ | ✓ | ✓ | ✓ | ✓ | ✓ | ✓ | ✓ |

Regulation Mode Parameters

Press the **SET** button for less than three seconds to access these parameters.



Auto Tuning

Range: On - Auto Tuning activated
Off - Auto Tuning deactivated

When this parameter is set to On, the controller begins auto tuning. After auto tuning is complete, the parameter is set to Off automatically. If this parameter is set to Off during the auto tuning process, the controller stops the auto tuning process immediately and does not change any PID parameter. A/M indicator will flash while Auto Tuning is in process.



Proportion Band

Range: 0.1 to 999.9

The Proportion Band is a parameter used for PID control.



Integral Time

Range: 0 to 9999 (Sec)

The Integral Time is a parameter used for PID control.



Derivative Time

Range: 0 to 9999 (Sec)

The Derivative Time is a parameter used for PID control.



PD Control Offset

Range: 0.0 to 100.0 (%)

The PD Control Offset parameter is available when the P or PD control is selected [Integral Time parameter  is zero].

This parameter defines the offset of the output. When the P or PD control is used, the control cannot stabilize the PV at the SV because the output is zero when the PV is equal to the SV. This parameter modifies the output level when the PV is equal to the SV.

01-5 / 02-5

Output 1 / Output 2 Hysteresis

Range: 0.0 to 999.9

The Output Hysteresis parameter defines the amount that the PV must go below or above the SV before the output turns on. This parameter is available only for On / Off control and hysteresis direction will be dependent on whether the output is set for heating or cooling.

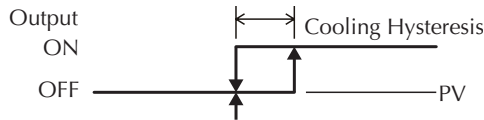
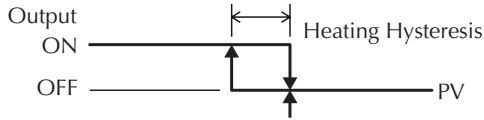

01-H / 02-H

Output 1 / Output 2 Heating Period

Range: 0.1 to 60 seconds (R0/R2 relay models - 5 to 60 seconds)

The Output Heating parameter defines one output period or the duration of one on / off cycle for the Output.

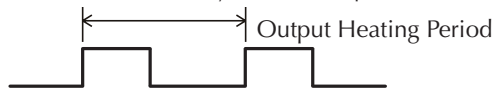

This parameter is available when the Output is programmed as a heating output. Available in PID and Manual mode.

01-C / 02-C

Output 1 / Output 2 Cooling Period

Range: 0.1 to 60 seconds (R0/R2 relay models - 5 to 60 seconds)

The Output Cooling parameter defines one output period or the duration of one on / off cycle for the Output.

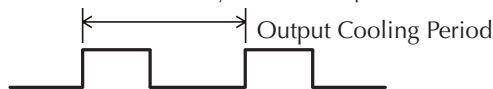

This parameter is available when the Output is programmed as a cooling output. Available in PID and Manual mode.

CoEF**Proportional Band Coefficient**

The PID proportional coefficient between Output 1 and Output 2 when a dual output control is selected. The P value of Output 2 equals the P value of Output 1 PID * **CoEF**. The I and D value of Output 2's PID are the same as Output 1's. Default value is 1.00.

DEAD**Deadband**

The deadband around the SV value. For example, if SV = 100 degrees and **DEAD** = 2.0, there will be no output when the temperature is between 99~101°C. See PID and On/Off control sections in chapter 5. Default value is 0.

Pv-F**PV Filter**

The process value filter takes the input and applies a rolling average to compensate for noisy signals. Filter equation: (Last displayed PV * **Pv-F** + Current Measurement) / (**Pv-F**+1). Range of 0 to 50 with a system default of 2.

Pv-r**PV Filter Range**

Process value filter range is the plus or minus range from the last displayed PV that PV Filtering will be applied. For very noisy signals the number must be large enough to capture large oscillations in signal. Range of 0.10 to 10.00 degrees with a system default of 1.

PvOFF**PV Offset**

The PV Offset is the amount added to the current process value. Range of -99.9 to 99.9 with a system default of 0.

PvGA**PV Gain**

The PV Gain is the multiplier applied to the current process value. Range of -0.999 to 0.999 with a system default of 0. Gain equation: PV = Current Measurement * (1 + **PvGA** / 1.000) + **PvOFF**.

RIHA**Analog High Adjustment**

The Analog High Adjustment value is added to the maximum analog output of 20ma in 1uA increments. If set to 500 the output will be 20.5ma at 100 percent output. Range of -3895 to 659 with a system default of 0. This parameter is only available on Current Output models.

RIAL**Analog Low Adjustment**

The Analog Low Adjustment value is added to the minimum analog output of 4ma in 1uA increments. If set to -100 the output will be 3.9ma at 0 percent output. Range of -964 to 3895 with a system default of 0.

This parameter is only available on Current Output models.

Operation Mode Parameters

Press the  button to access these parameters.



Run / Stop

The Run / Stop parameter is used to control the operational status of the SOLO Basic Controller. The controller can either be in run mode or stop mode. During stop mode the output is turned off but alarms remain active.



Run mode



Stop mode



Decimal Point Position

Range: 0 (****)

1 (**.*) Note: Maximum temperature displayed (PV) will be limited to "999.9".

This parameter defines the decimal point position on the PV and SV display.



Lock Mode

Range:  The Lock feature is disabled.





Lock Mode 1



Lock Mode 2

Lock Mode 1: All key pad operation is ignored.

Lock Mode 2: All key pad operation is ignored except changing the SV. To unlock press the  key and the  key at the same time to display  parameter. Enter the password to unlock the key. Default password is 0000.



Alarm 1 High Limit

This parameter is used to set the high limit for Alarm 1. The range and availability are dependent on the selected alarm mode.



Alarm 1 Low Limit

This parameter is used to set the low limit for Alarm 1. The range and availability are dependent on the selected alarm mode.



Alarm 2 High Limit

This parameter is used to set the high limit for Alarm 2. The range and availability are dependent on the selected alarm mode.



Alarm 2 Low Limit

This parameter is used to set the low limit for Alarm 2. The range and availability are dependent on the selected alarm mode.

OUT 1 / OUT 2

Output 1 / Output 2 Level

Range: 0.0 to 100 (%)

The value for this parameter can be changed in the Manual control mode. In other control modes, this parameter is read-only.

OUT 1 / OUT 2

Output 1 / Output 2 Upper Limit

Upper output percentage. Linear calculation is done between the upper and lower limit. Range of 0.0 to 100 with a system default of 100.

OUT 1 / OUT 2

Output 1 / Output 2 Lower Limit

Lower output percentage. Linear calculation is done between the lower and upper limit. Range of 0.0 to 100 with a system default of 0.0.

Initial Setting Parameters

Press the **SET** button for more than three seconds to access these parameters.

ENPT

Input Type

This parameter defines the input signal type.

| Thermocouple* Type and Temperature Range | | |
|--|-------------|-------------------------------|
| Input Temperature Sensor Type | LED Display | Temperature Range |
| Thermocouple TXK type | TXK | -238 ~ 1472°F (-150 ~ 800°C) |
| Thermocouple U type | U | -328 ~ 932°F (-200 ~ 500°C) |
| Thermocouple L type | L | -328 ~ 1562°F (-200 ~ 850°C) |
| Thermocouple B type | B | 212 ~ 3272°F (100 ~ 1800°C) |
| Thermocouple S type | S | 32 ~ 3092°F (0 ~ 1700°C) |
| Thermocouple R type | R | 32 ~ 3092°F (0 ~ 1700°C) |
| Thermocouple N type | N | -328 ~ 2372°F (-200 ~ 1300°C) |
| Thermocouple E type | E | 32 ~ 1112°F (0 ~ 600°C) |
| Thermocouple T type | T | -328 ~ 752°F (-200 ~ 400°C) |
| Thermocouple J type | J | -148 ~ 2192°F (-100 ~ 1200°C) |
| Thermocouple K type | K | -328 ~ 2372°F (-200 ~ 1300°C) |
| RTD Type and Temperature Range | | |
| Input Temperature Sensor Type | LED Display | Temperature Range |
| Platinum (Pt100) | PT | -328 ~ 1562°F (-200 ~ 850°C) |
| Platinum (JPt100) | JPT | -148 ~ 752°F (-100 ~ 400°C) |
| Copper (Cu50) | CU | -58 ~ 302°F (-50 ~ 150°C) |
| Nickel (Ni120) | NL | -112 ~ 572°F (-80 ~ 300°C) |

*Note: Use only ungrounded thermocouples.

EPUN

Temperature Unit

Range: F, C

Sets controller units to Celsius or Fahrenheit.

EP-H

Input Range High

This is the maximum value of the set point temperature range. The SV value cannot exceed the **EP-H** value. This parameter cannot be lower than the Input Range Low parameter (**EP-L**).

EP-L

Input Range Low

This is the minimum value of the set point temperature range. The SV value cannot be set lower than the **EP-L** value. This parameter cannot be higher than the Input Range High parameter (**EP-H**).

Ctrl

Control Mode

Range: **PLD** PID control mode
OnOff On / Off control mode
MANU Manual control mode

This parameter is used to select one of the control modes. See Chapter 5 for a complete description of each control mode.

S-HC

Heating / Cooling

Range: **H1** Output = Heating **H1H2** Output 1 = Heating
 Output 2 = Cooling **H1H2** Output 1 / 2 = Heating
C1 Output = Cooling **C1H2** Output 1 = Cooling
 Output 2 = Heating **C1H2** Output 1 / 2 = Cooling

The Heating / Cooling parameter defines whether one or two outputs will be controlled and what type of control they will perform.

ALA1

Alarm 1

ALA2

Alarm 2

Range: 0 to 9

The SOLO Basic models equipped with alarms support 2 alarm outputs. The Alarm1 and Alarm2 parameters are used to select the alarm type. Refer to Chapter 4 for details.

AL1a

Alarm 1 Options

Alarm standby until process value is within +/-5 of set point to prevent false triggers on startup xxxY (When Y=0: Normal, Y=1: Standby)
 Alarm output normally open or normally closed xxYx (When Y=0: NO, Y=1: NC)
 Hold alarm till power cycle or controller is stopped xYxx (When Y=0: Normal Reset, Y=1: Hold Alarm)
 Not used Yxxx

AL1d

Alarm 1 Delay

Length of time alarm condition must be active in seconds before alarm condition is triggered.

AL2a

Alarm 2 Options

Alarm standby until process value is within +/-5 of set point to prevent false triggers on startup xxxY (When Y=0: Normal, Y=1: Standby)
 Alarm output normally open or normally closed xxYx (When Y=0: NO, Y=1: NC)
 Hold alarm till power cycle or controller is stopped xYxx (When Y=0: Normal Reset, Y=1: Hold Alarm)
 Not used Yxxx

AL2d

Alarm 2 Delay

Length of time alarm condition must be active in seconds before alarm condition is triggered.

Reset to Factory Default



Note: Resetting the Temperature Controller back to factory default erases all of the values entered by the user. Record any necessary settings before proceeding



Warning: Erasing the user entered values may result in a safety hazard and system malfunction.

The following instructions reset the controller to the factory default.

- 1 Press the **↺** button until the parameter **LoL** appears. Use the **▲** button to select **LoL**. Press the **SET** button.
- 2 Press and hold the **SET** and **▲** buttons simultaneously for three seconds and release.
- 3 Use the **▲** button to change the value on the SV display to **135**. Press the **SET** button.
- 4 Display will change from **PASS** to **PAR-E**. Press **▲** to change value from no to yes and press set button.
- 5 Display will be fully lit and then controller will reboot.

Key Lock Function

Adjusting parameter of **LoE** to **LoE** in Operation Mode to lock all keys. **LoE** allows the SV value to be adjusted.

To unlock:

- 1 Press the **SET** and **↺** keys simultaneously in LOCK mode to display **KEYP**. Enter the password to unlock the key. Default password is 0000.

To change key lock password:

- 1 Press the **↺** key when **KEYP** is displayed to enter the password change screen **CHSP**.
- 2 Enter the current password. If the password is correct, **KEYP** will be displayed. If the password is incorrect, the screen will return to PV/SV display mode.

- 3 Once **EEP** is displayed enter the new password two times. The screen will return to PV/SV display mode with the keys unlocked. If two password entries do not match, the screen will return to step 2.



Note: If the password is lost or forgotten, restore the factory settings to reset lock condition.

CONTROLLER INPUTS AND OUTPUTS



CHAPTER 4

In this Chapter...

| | |
|---------------------------|-----|
| Control Input Types..... | 4-2 |
| Control Output Types..... | 4-2 |
| Alarm Outputs | 4-5 |

Control Input Types

Thermocouple or RTD Input

The SOLO Basic temperature controller can accept input from eleven types of thermocouples and four types of RTD sensors.

| Thermocouple* Type and Temperature Range | | |
|--|-------------|-------------------------------|
| Input Temperature Sensor Type | LED Display | Temperature Range |
| Thermocouple TXK type | | -328 ~ 1472°F (-200 ~ 800°C) |
| Thermocouple U type | | -328 ~ 932°F (-200 ~ 500°C) |
| Thermocouple L type | | -328 ~ 1562°F (-200 ~ 850°C) |
| Thermocouple B type | | 212 ~ 3272°F (100 ~ 1800°C) |
| Thermocouple S type | | 32 ~ 3092°F (0 ~ 1700°C) |
| Thermocouple R type | | 32 ~ 3092°F (0 ~ 1700°C) |
| Thermocouple N type | | -328 ~ 2372°F (-200 ~ 1300°C) |
| Thermocouple E type | | 32 ~ 1112°F (0 ~ 600°C) |
| Thermocouple T type | | -328 ~ 752°F (-200 ~ 400°C) |
| Thermocouple J type | | -148 ~ 2192°F (-100 ~ 1200°C) |
| Thermocouple K type | | -328 ~ 2372°F (-200 ~ 1300°C) |
| RTD Type and Temperature Range | | |
| Input Temperature Sensor Type | LED Display | Temperature Range |
| Platinum (Pt100) | | -328 ~ 1562°F (-200 ~ 850°C) |
| Platinum (JPt100) | | -148 ~ 752°F (-100 ~ 400°C) |
| Copper (Cu50) | | -58 ~ 302°F (-50 ~ 150°C) |
| Nickel (Ni120) | | -112 ~ 572°F (-80 ~ 300°C) |

**Note - Use only ungrounded thermocouples*

Control Output Types

The SOLO temperature controller supports three types of control outputs depending on the model chosen. The available outputs are Relay, Voltage Pulse and Current as shown in the controller part number.

SLB4848 - V 2

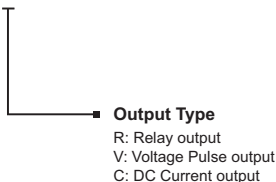

Relay Output

The relay used for the relay output in the SLB4848 is rated at a maximum 250 VAC and 5A resistive load. A secondary 250 VAC 3A resistive load output is available when using a model with alarms in one of the dual output modes.

The operation cycle of the Relay output is controlled by two factors, Output Level and Output Period.

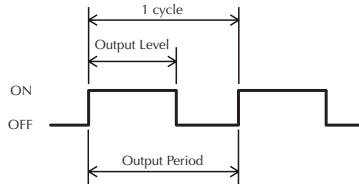

For example, when the Output Level is 60% and the Output Period is 10 seconds, the output relay is turned on for 6 seconds in the cycle.

There are six parameters that define these two factors.

Output Level

Output 1 Level (OUT1), Range: 0.0 to 100%

Output 2 Level (OUT2), Range: 0.0 to 100%

Output Period

Output 1 Heating Period (O1-H), Range: 5 to 60 seconds

Output 1 Cooling Period (O1-C), Range: 5 to 60 seconds

Output 2 Heating Period (O2-H), Range: 5 to 60 seconds

Output 2 Cooling Period (O2-C), Range: 5 to 60 seconds



Note: The electrical life expectancy of the relay output is 100,000 cycles. To maximize the life of the relay output, set a longer time value for the Output Period.

Voltage Pulse Output

The Voltage Pulse output generates a high level pulse of 12 VDC nominal and low level pulse of 0VDC. It can supply up to 40ma.

The operation cycle of the Voltage Pulse output is controlled by two factors, Output Level and Output Period.

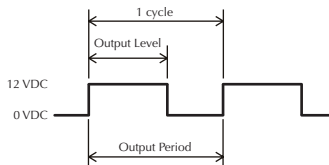

For example, when the Output Level is 60% and the Output Period is 10

seconds, the Voltage Pulse output is turned on for 6 seconds in the cycle.

There are three parameters that define these two factors.

Output Level

Output Level 1 (OUE), Range: 0.0 to 100%

Output Period

Output 1 Heating Period (OIH), Range: 0.1 to 60 seconds

Output 1 Cooling Period (OIC), Range: 0.1 to 60 seconds

Current Output

The Current output generates analog DC current with a range of 4-20 mA. The maximum load resistance is 600 Ω .

The output current is controlled by four factors, Analog High Adjustment, Analog Low Adjustment, Output Level and Output Period.

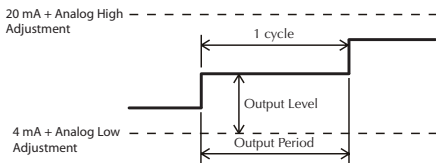

The Analog High Adjustment value may be changed to adjust the output current when the Output Level is 100%.

The Analog Low Adjustment value may be changed to adjust the output current when the Output Level is 0%.

The Output Level determines the output current level between “20mA + Analog High Adjustment” and “4mA + Analog Low Adjustment”.

The Output Period sets how often the SOLO controller updates the output value.

There are seven parameters that define these four factors.

Analog High Adjustment

Analog High Adjustment (AIA), Range -3895 to 659 μ A.

Analog Low Adjustment

Analog Low Adjustment (ALA), Range -964 to 3895 μ A.

Output Level

Output 1 Level (OUT1). Range: 0.0 to 100%

Output 1 Upper Limit (OUT1U). Range of 0.0 to 100%

Output 1 Lower Limit (OUT1L). Range of 0.00 to 100%

Output Period

Output 1 Heating Period (OUT1H). Range: 0.1 to 60 seconds

Output 1 Cooling Period (OUT1C). Range: 0.1 to 60 seconds

Alarm Outputs

The SOLO Basic controller can support two alarms on select models.

See the Alarm Output Chart on the following page.

Alarm Output Types

| Set Value | Alarm Type | Alarm Output Operation |
|-----------|--|------------------------|
| 0 | Alarm function disabled | Output is OFF |
| 1 | Deviation upper- and lower-limit: Alarm output activates when PV value is higher than the setting value $SV+(AL-H)$ or lower than the setting value $SV-(AL-L)$. | |
| 2 | Deviation upper limit: Alarm output activates when PV value is higher than the setting value $SV+(AL-H)$. | |
| 3 | Deviation lower limit: Alarm output activates when PV value is lower than the setting value $SV-(AL-L)$. | |
| 4 | Absolute value upper and lower limit: Alarm output activates when PV value is higher than the setting value $AL-H$ or lower than the setting value $AL-L$. | |
| 5 | Absolute value upper limit: Alarm output activates when PV value is higher than the setting value $AL-H$. | |
| 6 | Absolute value lower limit: Alarm output activates when PV value is lower than the setting value $AL-L$. | |
| 7 | Hysteresis upper limit alarm output: Alarm output activates when PV value is higher than the setting value $SV+(AL-H)$. The alarm output turns OFF when the PV value is lower than the setting value $SV+(AL-L)$. | |
| 8 | Hysteresis lower limit alarm output: Alarm output activates when PV value is lower than the setting value $SV-(AL-H)$. The alarm output turns OFF when the PV value is higher than the setting value $SV-(AL-L)$. | |
| 9 | Disconnection Alarm: This alarm output is enabled if the sensor connection is incorrect or has been disconnected. | |

***Note: Alarm types 1-9 will enable the alarm output if a sensor disconnect or incorrect connection is detected.**

CONTROL MODES



CHAPTER

5

In this Chapter...

| | |
|--------------------------------|-----|
| PID Control | 5-2 |
| On / Off Control | 5-3 |
| Manual Control..... | 5-3 |
| Error Display Information..... | 5-3 |

The SOLO Basic controller can be configured for any of the following control modes.



- PID control
- On / Off control
- Manual control

PID Control

Auto Tuning

The SOLO Basic controllers support an Auto Tuning feature to set up the following PID parameters automatically.

| | |
|-------------|-------------------|
| P | Proportional Band |
| I | Integral Time |
| D | Derivative Time |
| Pdof | PD Control Offset |

Use the  and  buttons to set the desired setpoint and press **SET** to save before starting the auto-tune process.

To start the Auto Tuning, set the parameter Auto Tuning (**AT**) to On. The controller automatically controls the output to change the PV as shown below.

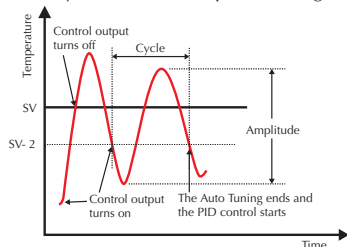

Once the Auto Tuning process is completed, the SOLO Basic controller calculates the above PID parameters and starts the PID control with the new parameter values immediately.

Deadband

The range around the PV in which the heating/cooling outputs remain off. A negative deadband has the opposite effect allowing both outputs to be on in the area around the PV.

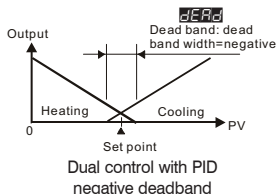
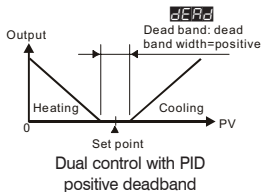

On / Off Control

In the On / Off control mode the output is controlled according to the difference between the SV and the PV. If the PV is lower than the SV and the output is set for heating, the heating output is turned on. If the PV is higher than the SV and the output is set for cooling, the cooling output is turned on. Hysteresis can be used to avoid output chatter and when in dual output mode Deadband will help prevent bouncing between heating and cooling.

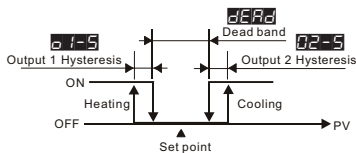

Dual loop ON / OFF control output operation

Hysteresis

If heating, this is the value below the set temperature that the PV must fall to before the output will turn on. If cooling, this is the value above the set temperature that the PV must rise to before the output will turn on.

Deadband

The range around the PV in which the heating/cooling outputs remain off. A negative deadband has the opposite effect allowing both outputs to be on in the area around the PV.

Manual Control

In the Manual control, the output of the controller is manipulated manually by the operator. Adjust the values of the Output Level parameters (`OUT1`, `OUT2`) to control the output levels.

Error Display Information

The chart below illustrates the possible error displays shown on the SOLO Basic Temperature controller.

| Controller Error Display | | | | |
|--------------------------|---------|-------------------|---|--|
| Display Position | Display | Meaning | Cause | Corrective Action |
| PV | no | No sensor input | The input terminals are open. | Check the input wiring. If the problem still exists, replace the sensor or the controller. |
| SV | Err | | | |
| PV | SEn | Sensor Type Error | Temperature is out of range for sensor type | Check sensor type and it's condition. If damaged or wrong replace and update settings. Check actual condition to make sure temperature is within sensor range. |
| SV | Err | | | |

